



This is a digital copy of a book that was preserved for generations on library shelves before it was carefully scanned by Google as part of a project to make the world's books discoverable online.

It has survived long enough for the copyright to expire and the book to enter the public domain. A public domain book is one that was never subject to copyright or whose legal copyright term has expired. Whether a book is in the public domain may vary country to country. Public domain books are our gateways to the past, representing a wealth of history, culture and knowledge that's often difficult to discover.

Marks, notations and other marginalia present in the original volume will appear in this file - a reminder of this book's long journey from the publisher to a library and finally to you.

Usage guidelines

Google is proud to partner with libraries to digitize public domain materials and make them widely accessible. Public domain books belong to the public and we are merely their custodians. Nevertheless, this work is expensive, so in order to keep providing this resource, we have taken steps to prevent abuse by commercial parties, including placing technical restrictions on automated querying.

We also ask that you:

- + *Make non-commercial use of the files* We designed Google Book Search for use by individuals, and we request that you use these files for personal, non-commercial purposes.
- + *Refrain from automated querying* Do not send automated queries of any sort to Google's system: If you are conducting research on machine translation, optical character recognition or other areas where access to a large amount of text is helpful, please contact us. We encourage the use of public domain materials for these purposes and may be able to help.
- + *Maintain attribution* The Google "watermark" you see on each file is essential for informing people about this project and helping them find additional materials through Google Book Search. Please do not remove it.
- + *Keep it legal* Whatever your use, remember that you are responsible for ensuring that what you are doing is legal. Do not assume that just because we believe a book is in the public domain for users in the United States, that the work is also in the public domain for users in other countries. Whether a book is still in copyright varies from country to country, and we can't offer guidance on whether any specific use of any specific book is allowed. Please do not assume that a book's appearance in Google Book Search means it can be used in any manner anywhere in the world. Copyright infringement liability can be quite severe.

About Google Book Search

Google's mission is to organize the world's information and to make it universally accessible and useful. Google Book Search helps readers discover the world's books while helping authors and publishers reach new audiences. You can search through the full text of this book on the web at <http://books.google.com/>

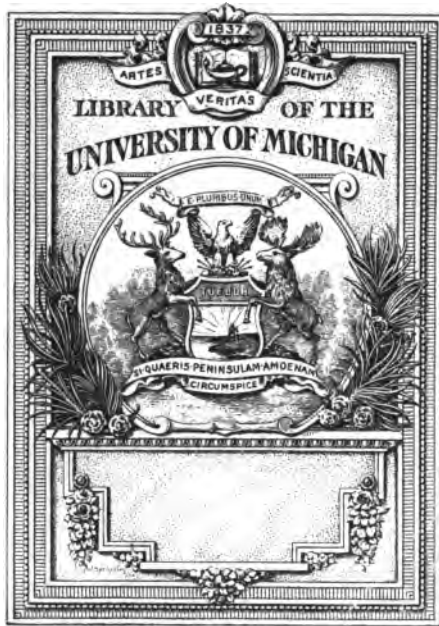

Astron.
Obs

Astronomical
Observatory

TS
545
.685

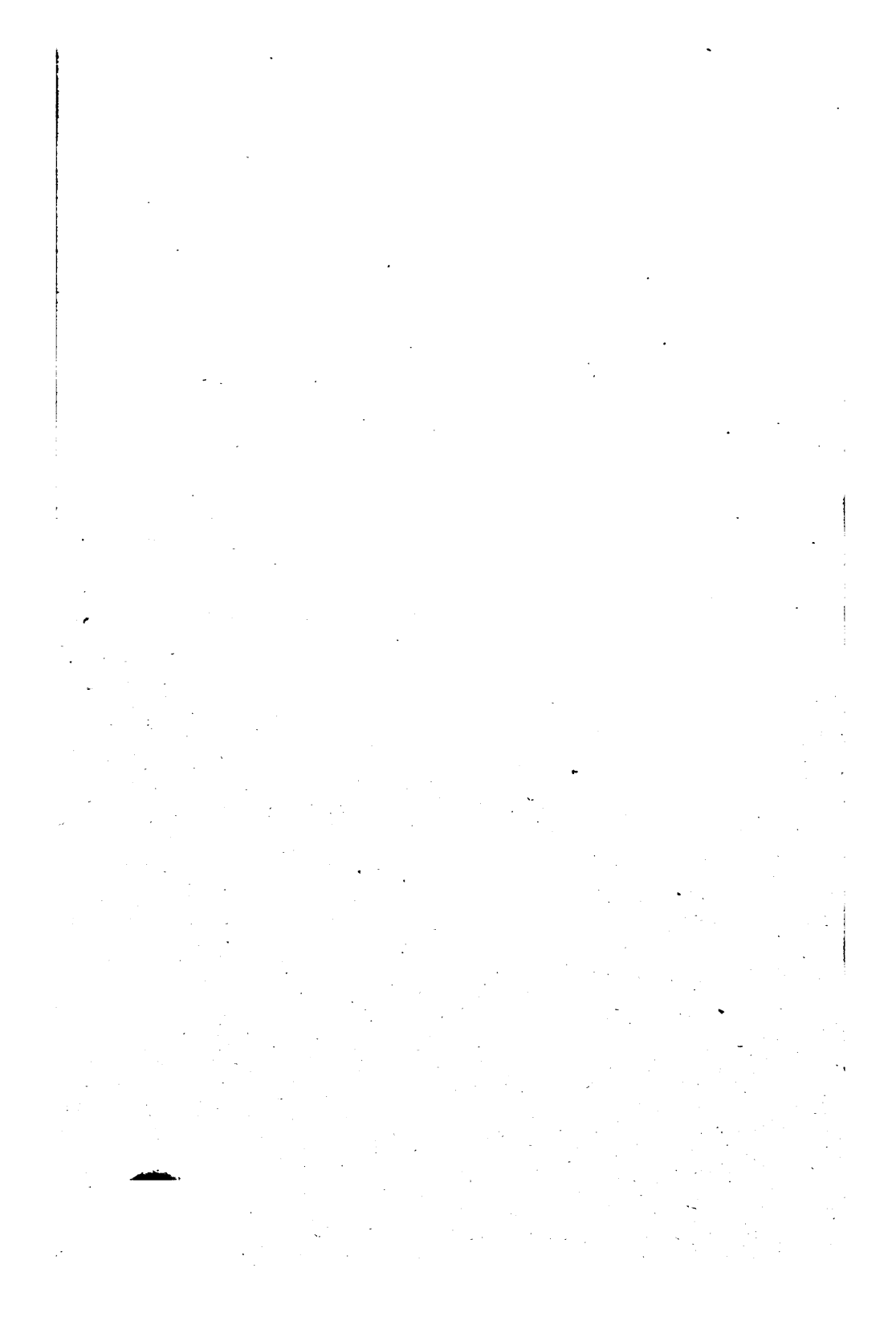

PRACTICAL COURSE IN
ADJUSTING.

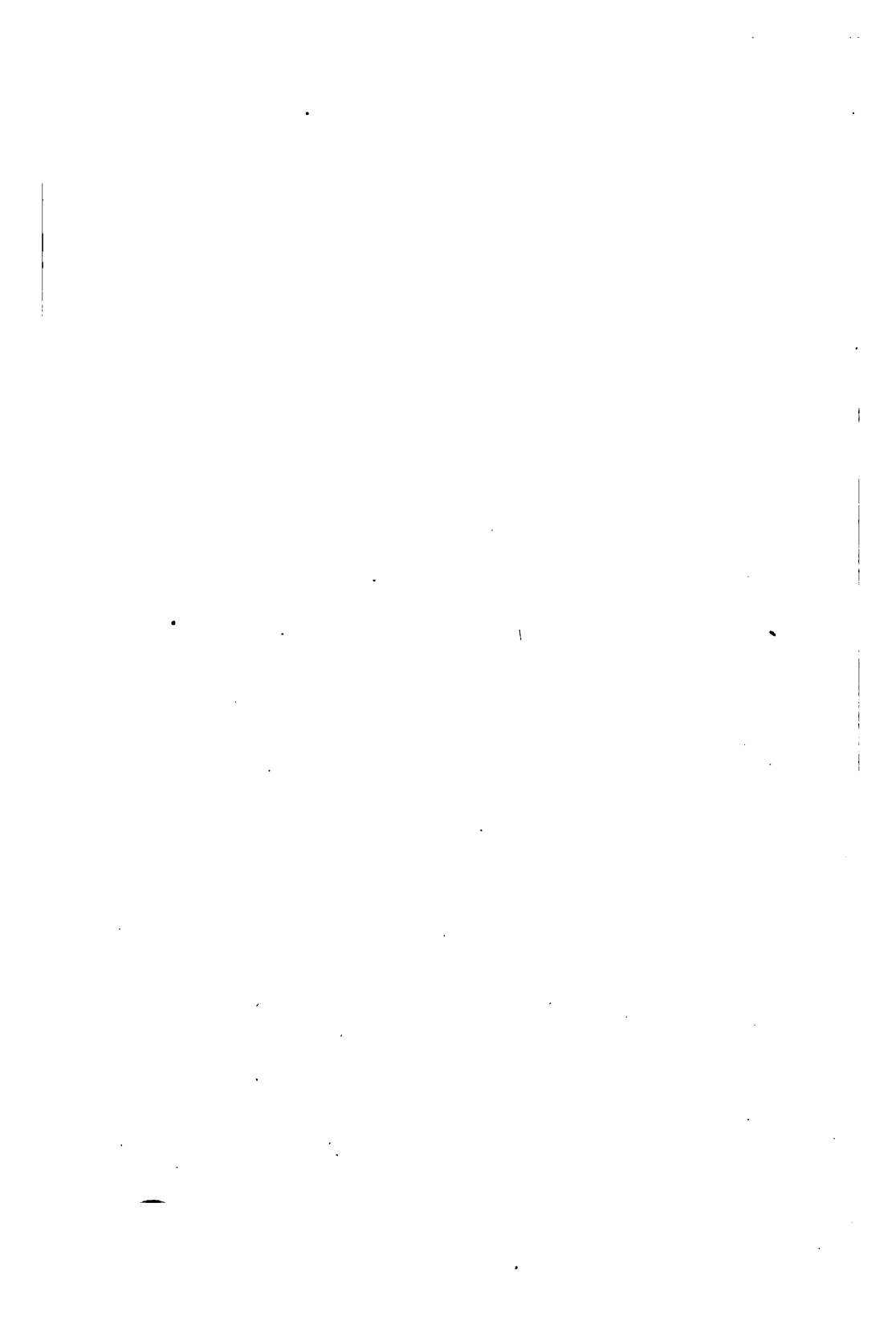

PRACTICAL COURSE IN
ADJUSTING 107453

COMPRISING

a review of the laws governing the motion of the balance and balance spring in watches and chronometers, and application of the principles deduced therefrom in the correction of variations of rate arising from want of isochronism, change of position and variation of temperature.

ELUCIDATED AND DEMONSTRATED

by original experimental researches in the actual problem, never before published, showing the causes that are operative in the variation of rate, and leading to correct remedies. To which have been added chapters on

HOW TO MAKE A BALANCE ARBOR
WITH MODERN APPLIANCES; HOW
TO CLEAN A WATCH PROPERLY;
AND, THE LEVER ESCAPEMENT—
SOME CURRENT DEFECTS IN IT AND
HOW TO REMEDY THEM.

By *THEO. GRIBI*

1901

THE JEWELERS' CIRCULAR PUB. CO.
11 John St., New York.

Copyright by Theo. Gribi; assigned to The Jewelers' Circular Pub. Co.
All rights reserved.

Copyright 1896,
by
THEO. GRIBI.

Copyright 1899, 1900, 1901,
by
THE JEWELERS' CIRCULAR PUBLISHING CO.

All rights reserved.

Recd. 4-23-38 ju

TABLE OF CONTENTS

INTRODUCTION

Chapter I

General principles underlying the adjustment of watches and chronometers.

1	Statement of the Problem	1
2	Fundamental Principles of the Isochronism of the Balance Spring	2
	Definition of, by Sir Robert Hooke—Ferdinand Berthoud	
	—Law of the progression of the force of the spring	
	—demonstration of—M. Phillips' terminal curves.	
3	Disturbing Factors Inherent in the Balance and Spring	4
	<i>a Effect of centrifugal force.</i>	
	Discussion of M. Phillips' equation to the movement of the balance.	
	<i>b Effect of the inertia of the spring.</i>	
4	Disturbing Factors that Exist in Conditions Outside of the Balance and Spring	5
	<i>a Resistance of the air.</i>	
	<i>b Influence of the impulse in the chronometer escapement.</i>	
	<i>c Influence of the impulse and unlocking in the lever escapement.</i>	
	<i>d Influence of the regulator pins.</i>	
	<i>e Effect of friction as bearing upon the isochronism of the spring.</i>	
5	Isochronism of the Flat Spring	12
	Eccentric motion of the spring—effect of—oscillation of the center of gravity—pressure on balance pivots—torsion—varies with angular distance of terminal	

pinning—varies with the arcs of motion of the balance—experimental demonstration—tables of results and graphic illustration—result with “Bréguet” and cylindrical springs the same.

6 Isochronism as Affected by Changes in the Length of the Spring..... 26
Results of experiments—current rules proved false—equation to the movement of the balance insufficiently determined.

7 Terminal Curves..... 32
Theory of terminal curves—M. Phillips’ formula for their construction—various and simple curves constructed according to formula.

8 Correction of Terminal Curves..... 36
Without theoretical terminals no isochronism—effect of non-theoretical terminals—cases in which they may be useful—rules for the deformation of them in order to accomplish a desired result.

Chapter II

Adjustment in Positions.

9 Position Error..... 45
General Discussion.

10 Proper Motion of the Balance Spring..... 46
A motion distinctly different from the eccentric motion of the spring—resultant of radial and circular motion—never before sufficiently dealt with—method of analyzing and demonstrating it—exists in cylindrical springs as well as in flat ones—everything else being perfect it is the sole remaining cause of position error—cannot be wholly removed or remedied by the most perfect terminal curves—position error greater in cylindrical than in flat springs.

11 Experimental Demonstrations..... 55
a The flat spring.
Position error under arcs of motion of 440° —varies as the terminal pinning—graphics illustrating results of experiments—experiments and graphics illustrating position error under variable arcs of motion.

b The cylindrical spring.

With and without theoretical terminals—exhibits the same position error as the flat spring—correct terminals reduce the error but do not remove it—how to measure the arcs of motion of the balance.

12 Practical Deductions..... 75

Position error constantly varying with the arcs of motion limits between which they ought to range—uselessness of trials for position error of less than 24 hours—how to orient the terminal pinning of the balance spring for the best position adjustment—anomalous and erratic variations—mean rate in vertical positions generally slower than in horizontal ones—precaution to be taken against it—suggestion of applying two springs to the same balance.

13 A Discovery and a Remedy..... 78

Chapter III

Compensation for Variation of Temperature.

14 Temperature Error..... 82

The best understood of all the disturbing factors—experiment of Dent with glass balance—experiment of Delamarch and Ploix with brass balance—principal factors operating to cause temperature error.

15 Ordinary Compensation Balance..... 83

Analysis of the movement of the balance—graphic of the rate of a non-compensated balance—graphic of the rate of a compensated balance—secondary error—temperature of compensation—formula used in the U. S. Naval Observatory for calculating the rate of a chronometer—reasons for adopting a higher temperature of compensation for watches than for ship chronometers.

16 Auxiliary Compensation..... 88

Cause of secondary error not well defined—why auxiliary compensation is necessary—principal of action of—ideal form of—competitive trial at the Geneva (Switzerland) Observatory—the use of nickel-steel for balances and balance springs.

Chapter IV

Application of correct principles in the construction of watches and practical work of adjusting.

17 Mechanical Defects 92

The most detrimental ones are in the escapement—locking and draw—too much passage-way of the fork—freedom of the impulse pin—weight of the escape wheel—effect of—balance pivots and jewels—end-stones—poising of the balance—position error no proof that balance is out of poise—poise of the lever less important than the reduction of its weight—the train—mainspring—development of its force—largely dependent upon the manner of hooking it to barrel—how to make a hook—graphic of the development of the force of the spring—lesson to be drawn from—table of lengths and thickness of spring to given barrel—conditions relative to pinning in balance springs—concerning regulator pins.

18 Putting in Balance Springs 108

Flat spring without theoretical terminals—method of selecting it—“Vibrator”—timing by vibrating in unison with—pinning into collet with a view to position adjustment—bringing balance to mean time by timing washers.

19 Formation of Theoretical Terminals..... 112

Method of forming inside terminal—finding opening to be made for, from given elements of curve—making a drawing of—tools and accessories for forming and comparing it with drawing—conditions to be observed in pinning into collet and centering it. Formation of outside terminal—adapting regulator pins to given curve—correct terminals do not wholly prevent position error—finding the point in the spring where to commence the outer curve for position adjustment—how to make a drawing from the elements of the curve—series of different curves for special cases—finding of the length of the curve—curves that can be used in flat springs without changing the position of the regulator pins.

20 Timing Washers..... 126

Accessories for making them and how to apply them.

21 Orderly Proceeding with the Work.....128
First trial for isochronism—the kind of record to be kept of—advantage of such record—importance of preliminary trials—necessity of a correct standard of comparison—method of making and recording observations—practical example—trials in position error—practical example—effect of manipulating the regulator pins—tools for doing it—effect of placing a weight on the balance spring to correct position error—adjustment to isochronism must precede temperature adjustment—practical example and manner of keeping a record in adjusting to temperature.

22 Adjustment Between Horizontal Positions .. 143
Reasons for postponing it until all the other adjustments are satisfactory—causes of difference of rate between “dial up” and “dial down”—how to equalize rate by balance pivots—practical example showing how unlooked for defects interfered with adjustment and how they were remedied.

23 Standard of Excellency of the Performance of Watches.....148
Worthlessness of popular claims of performances—uselessness of superficial observations—the only correct test of performance—standard of excellency adopted at the Geneva (Switzerland) Observatory.

24 On the Use of the Plus and Minus Signs in Rating Watches..... 149

Chapter V

How to make a Balance Arbor with Modern Appliances..... 153

Chapter VI

How to Clean a Watch Properly..... 171

Chapter VII

The Lever Escapement, its Current Defects and How to Remedy Them When Possible... 176

ERRATA.

- Page 11—Line 2, read *none* instead of non.
- Page 2—Heading 2, read *fundamental* instead of fundimental.
- Page 4—Line 13 from top in interpretation of symbols used in equation, read : π “ “ 3.1415, etc.
- Page 4—Line 14 from top ; read *moment of inertia*, instead of moment of the inertia.
- Page 9—Line 19 from bottom read *impulse* instead of impuse.
- Page 21—Lines 12 and 21 supply *e* in first words.
- Page 49—Top line, remove brackets.
- Page 87—In definition of symbols of formula read : θ' , instead of $\theta =$ any other temperature.
- Page 105—Line 9 from bottom, read : *No.* instead of Nos.
- Page 142—Line 14 from top read : ± 31.2 instead of $+31.2$

INTRODUCTION.

THESE is probably no subject so near and dear to the heart of the watchmaker; non for information on which he is thirsting so much as that of "adjusting." To state the matter in terms of my own appreciation and experience, I have scarcely known a day since I have worked at the bench when I have not searched for and eagerly welcomed light on the subject. In saying this I am but echoing the sentiment of hundreds with whom I have come in contact, either personally or by correspondence. Its attractions lie not only in the fact that it affords scope for the exercise of the higher intellectual faculties, but that, be he ever so good a workman otherwise, it is after all the most important part of a watchmaker's knowledge—that which will pay him best. Many an otherwise faultlessly constructed watch will fail to give the required satisfaction because of some slight defect in the adjustment of the balance spring. The man who, by a few touches, often requiring very little time, can make such a watch perform properly, will win the favor of his customer every time; he possesses an advantage over his less informed fellow workmen that always makes him master of the situation.

The work of adjusting is not difficult, nor does it require costly tools. It is simply a matter depending upon a knowledge of the laws that govern the motion of the balance and balance spring under varying circumstances and conditions. There is no trick about it, nor is there any haphazard in it. These laws are just as permanent and their result as sure as are those of the movements of the heavenly bodies; but they must be understood. Hitherto, what knowledge we did have of them has been in the possession of comparatively few; mostly men working in the manufacturing districts abroad, and even among these, adjusting until recently has been more a matter of skill than of scientific knowledge.

For a long time the problem of the balance spring, unlike that of the pendulum, was an inscrutable mystery

to watchmaker and mathematician alike, although it had attracted the latter at a very early period. Some general but more or less vague notions as to its isochronal properties were entertained, but the realization of it was like the pursuit of the Will o' the wisp. Not until some 37 years ago, when the learned engineer, M. Phillips, for the first time applied the resources of mathematical analysis to the solution of the problem, was anything like settled knowledge given to us. His "Memoir on the Balance Spring," Paris, 1861, was a contribution to horology of inestimable value. It opened the way to a host of other searchers, prominent among the names of whom are those of Yvan Villarceau, E. Caspari, M. Le Dieu and Jules Grossman, each treating the subject from a more or less different point of view, bringing new truths to light. Notwithstanding all this, the watchmakers did not seem to realize that perfection of results in their work of adjusting that might have been expected consequent upon the application of the principles established by these mathematicians. The question naturally arose: Whether the watchmakers were skilful enough to properly apply the data furnished by the mathematicians, or whether the cause of their failure was the omission, by the latter in their calculations, of some important factor playing a part in the problem?

In regard to this controversy it may be said that, so far as the watchmaker is concerned, at least he who had the necessary practical training, there is nothing which his patience and perseverance could not conquer, and, although the theoretical development of the mathematicians were for the most part couched in language unintelligible to the ordinary watchmaker, yet there were plenty who perfectly understood their general conclusions if not wholly the process of reasoning. On the other hand, it should be observed that the problem of the balance spring and its adjustment is one involving a great many factors interworking with one another, and that mathematical analysis can deal with and determine only one of them at a time; and although it can determine all of them, one after the other separately, it cannot predict the final resultant of the interworking of all of them. But this is the very thing which the watchmaker needs to know and to solve; he always has to deal with the prob-

lem in its concrete form. As the case appeared to the writer some twenty years ago, much as the watchmaker had cause to be grateful to the mathematicians for valuable aid, if the problem was ever going to be solved satisfactorily, it would have to be solved by the watchmaker. Assuredly, up to date, mathematical science, valuable as are its contributions, has not done it.

It was the writer's good fortune when on a visit to Geneva, Switzerland, in 1878, to participate in a series of meetings of the watchmakers' society, a sub-class of the Société des Arts. At one of these meetings M. Adrian Philippe, member of the firm of Patek, Philippe & Co., read a paper on the flat balance spring, in which he took the ground that the latter was in every respect the peer of the so-called Breguet spring. The argument he made, supported by observations extending over a number of years, together with the discussion that followed, affected me profoundly. I said to myself: why should not a series of rationally and systematically conducted experiments by way of observing the rate of watches under varying and known conditions, in the same way as we observe any other physical phenomenon we desire to study, lead to a more satisfactory solution of the problem than mathematical analysis had hitherto furnished us? Experimental science is the basis of much of our knowledge. "We must consult experiment," says Leonardo da Vinci, "and vary the circumstances till we have deduced general rules, for it alone can furnish them to us."¹

The problem before the watchmaker is the determination: 1st, of the causes which make watches vary in their rate; 2d, the laws which govern these variations, and 3d, the physio-mechanical conditions on which they depend. I felt convinced that experiments made in the right way, assisted by what data mathematical analysis has furnished, would go a great way toward solving that problem, and I promised myself then that if ever I had the opportunity I would try it. This opportunity did present itself, I took advantage of it and the result of the experiments I then made constitute, in the main, the basis of the present work.

These experiments, the nature, method and process of which will be explained in the proper places, were made

¹ Venturi, *Essai sur les ouvrages de Leonardo da Vinci.*

principally with a ship chronometer which I had fitted up to be run by weight as motive power, instead of the spring. I framed the movement in such a way that I could make it run in vertical positions as well as in horizontal ones without making any other changes in the conditions under which it was running. The whole was under a glass globe before me with a mirror under it reflecting the dial, so that I could, at any time, see both the arcs of motion of the balance and the time it indicated on the dial. I had a fine English mercurial pendulum clock, beating seconds, for a standard; and this I had the means of controlling by daily telegraphic time signals direct from the Observatory. Besides this ship chronometer I used watches, many of which I had purposely prepared with a view of making them as near mechanically perfect as possible. It will be found, I trust, that these experiments were conducted on rational and systematic yet entirely different lines from those of my predecessors, who treated the subject by the aid of mathematical analysis. There are no mathematics in my work other than what the plainest workman can understand, and the shape in which the results are now presented must enable the attentive reader, lay or professional, to comprehend them at once, almost without the labor of thinking. The actual experiments in question cover a period of six years, from 1879 to 1885, and the reduction of the results as many more years and no small amount of tedious work. These results are now published for the first time.

The form in which the work appears is the outcome of a series of lectures delivered before the American Horological Society during the Winter of 1896 and 1897, comprehending a complete practical course on adjusting. I have, therefore, added to my own personal researches all that which, of the knowledge extant on the subject, is important and useful, giving due credit to the sources from which I have drawn. I am particularly indebted to the labors of M. Louis Lossier, principal of the horological school at Besançon, France—now deceased—whose work, "*Etude sur la théorie du réglage*," Geneva, 1890, has appeared since, and from which I have drawn much valuable information. Those of my readers who have read that work will find that in part we have covered the same ground and that in the main characteristics our conclu-

sions are identical. In so much as our results differ I must claim greater weight for mine for the reason that my method dealt with the concrete problem while his treated of isolated factors only.

The present work is designed principally for the watch repairers of this country who may have occasion to adjust watches or make adjusted watches keep still better time. But I trust that it may find interested readers among such of my professional colleagues abroad who are familiar with the subject of adjusting and who are therefore qualified to judge and appreciate what merit it possesses. Perhaps, also, I may entertain the hope that my small contribution may stimulate some to fill up its shortcomings by continuing the researches on the same lines and completing the solution of the problem we are battling with.

To my readers on this side of the Atlantic I desire to say that while this work is intended as a help to the ordinary watchmaker, it must be understood that it cannot undertake to teach a novice. The reader, in order to make practical use of its contents must be sufficiently advanced in the knowledge of watchmaking; he must be familiar with the principles of a correctly constructed watch and must have sufficient practical experience at the bench to be able to do work properly. The watchmaker cannot expect of a work like this, for instance, that he will find in it instruction how to go about correcting defects in an escapement, etc.; all it can do is to point out what defects are to be corrected; the necessary knowledge he must seek in other works and from teachers who make the imparting of this knowledge their business. Those who will make an effort to acquire that knowledge will find the present work an invaluable aid in completing their education.

I make no pretensions to literary ability, and, therefore, make no apology for shortcomings in this respect. If I have succeeded in making the subject of my discourse clear and intelligible to the reader the end I had in view in that respect is attained. Nor do I for a moment suppose that I have solved the entire problem, much less that I have exhausted the subject. I have, I believe, been able to turn more light on some phases of it by, it is true, an old avenue of approach, but one which

had not been thoroughly made use of hitherto. If the facts and results I have brought out shall prove a real assistance to those who labor in this field and who take pleasure in the acquisition of knowledge concerning it, I shall have reaped all the success I desired.

CHICAGO, Sept. 19, 1898.

THE AUTHOR.

PRACTICAL COURSE IN ADJUSTING.

CHAPTER I.

GENERAL PRINCIPLES UNDERLYING THE ADJUSTMENT OF WATCHES AND CHRONOMETERS.

1. Statement of the Problem.—Given a watch, the motion of whose balance would be uniform or isochronous, *i. e.*, the vibrations of whose balance would always be performed in equal times, whatever the conditions the watch might be subject to, such as variation in temperature, changes in position, etc., it is evident that its rate would be uniform. This uniformity of rate it is which the work of adjusting is designed to accomplish. It will be observed, however, that the term "isochronism" here implied has a wider meaning than when used merely to designate the principle of isochronism in the spring; that, in fact, it embraces all sorts of conditions, inherent and extraneous, and it may be proper to inform the reader, at the outset, that such an isochronism is not so easily obtained. It may be well, even to warn him that such perfection is hard to realize, and that after we have done our best we may, perhaps, have to be satisfied with approximations. There are difficulties to be met which require an intimate knowledge of the laws and conditions governing the motions of the balance, hitherto imperfectly understood but which it is the object of this treatise to elucidate.

In the manufacturing centers of Europe the work of the adjuster (*régleur*) is simply that of "springing," *i. e.*, of *properly adapting a spring* to the balance and adjusting the latter to temperature, organic defects in the watch being corrected by the manufacturer. But in this country the repairer who may be called upon to adjust watches

is frequently obliged to make extensive corrections in the escapement and other parts of the watch which, though not properly belonging to the work of adjusting, are necessarily to be included in a treatise on the subject. In emphasizing the words "properly adapting a spring" above, I wish it to be understood that it embraces all the difference between mere so-called "springing" and timing, and intelligently regulating to positions and isochronism.

The adjustment of watches divides itself naturally into three branches, which, though interrelated in such a way that it may be said that one cannot exist without the other two, are yet, in a sense, independent of each other, each resting on entirely different laws touching the motion of the balance and spring. They are:

1. The adjustment to isochronism, resting—disturbing factors apart—purely on the elastic force of the spring.
2. The adjustment to positions, resting on the laws of gravity as affecting the mass of balance and spring, and
3. The adjustment to temperature, resting on the laws governing the expansion and contraction of metals subject to changes of temperature.

Let us deal with them in the order here stated:

2. Fundamental Principles of the Isochronism of the Balance Spring.—A notion of the principle of the isochronism of the balance spring is contained in the utterance attributed to Sir Robert Hooke (1635-1702), "*ut tensio sic vis*"—as is the tension so is the force; but Ferdinand Berthoud was undoubtedly the first to give it intelligent meaning in the statement that, for the balance spring to be isochronal, *i. e.*, to cause the balance to move alternately through long and short arcs in one and the same time, its force, or the power which would hold it in equilibrium under any given tension, must vary as the arcs.¹ To prove this statement the following verbal demonstration will suffice:

Assume a body in motion traveling over a given distance in a given time. If it were required to travel over twice the distance in the same time, its velocity would

¹ *Traité des Horloges Marines, Paris, 1773.*

have to be doubled, and if over three times the distance, trebled, etc. Applying this principle to the motion of the balance: Assume that the latter moves over a given arc in a given time. If it were required to perform double the extent of arc of motion in the same time, it would have to move with double the velocity, and for three times the extent of arc, with three times the velocity, etc. It can readily be seen that this would be the case if the force of the spring that gives it motion, as developed by its inflections, increases in the same ratio as the velocity. Now the velocity increases as the arcs, the time remaining the same. If, therefore, a balance be required to move alternately over arcs of 45° , 90° , 135° , 180° , 225° and 270° (semi-vibrations) in one and the same time, the corresponding force of the spring, as developed by its inflections would have to be: 1, 2, 3, 4, 5 and 6; in other words, the development of the force of the spring must vary as the arcs, in arithmetical progression. The science of mechanics further shows that when that is the case, its momentum, which is the force it acquires through motion, will increase in geometrical progression, *i. e.*, as the square of the arcs, which is also the momentum of the balance.

In more recent times the application of the higher mathematics to the solution of the problem has made us still more intimately acquainted not only with the fundamental principles of isochronism, but with many a factor, the existence of which, as an interference, was formerly not even suspected, but which we are now able to combat more or less successfully. Thus M. Phillips, in his masterly analysis,² has given us the equation of the movement of the balance under the action of the elastic force of the spring, and has shown that in order to realize the law of the arithmetical progression in the development of the force of the spring, the terminals of the latter must have a given form and has furnished us with the formula for their construction.

For the purpose of forming a clear conception of the problem before us, let us briefly examine the leading disturbing factors with which we have to deal in seeking for isochronism. They are of two kinds: *Such as are in-*

² *Le Spiral réglant*, Paris, 1861.

herent in the balance and spring themselves, and such as exist in conditions outside of them.

3. Disturbing Factors inherent in the Balance and Spring.

a. Effect of centrifugal force.

In the equation of the movement of the balance M. Phillips has given us the time of its vibrations in terms of the inertia of the balance and the elastic force of the spring, viz.:

$$T = \pi \sqrt{\frac{AL}{M}}$$

in which

T stands for the time or duration of one vibration.

“ “ “ “ number 3.1415 . . . etc.

A “ “ “ moment of the inertia of the balance.

L “ “ “ length of the balance spring,

and M for the elastic force of the spring; and he claims that because he has succeeded in eliminating the arcs in the process of its development, the vibrations will be isochronal howsoever they may vary in extent. This, however, while theoretically true, will utterly fail in practice, as will presently be shown. Nor will the application of the most perfect terminal curves, which he subsequently shows to be a condition of isochronism, prevent the failure, as we shall hereafter show.

In order that the quantity represented by T in the above equation should be invariable, the quantity in the right hand member of the equation, under the radical, must be invariable also. But this we know is not the case. In fact, A, or the inertia of the balance, being the product of the mass into the square of the radius, varies with the arcs, as the effect of centrifugal force; for, the rim being cut in a compensation balance, the effect of centrifugal force is to expand it and throw its weight further from the center during greater arcs of motion, the result being the retarding of the long arcs as compared with the duration of the short ones. This factor, insignificant and neglectable as it may be in watch balances, is considerable and not to be overlooked in ship chronometers, in which the balance rim is generally loaded with heavy compensating weights. M. Phillips,

in the work before quoted, and E. Caspari³ have both investigated the effect of centrifugal force upon the balance and have found that it varies *directly* with the square of the arcs of vibration, and *inversely* as the square of the time in which they are performed, *i. e.*, it increases as the arcs of motion increase in extent, and is less in a balance whose vibrations are slower. Calculating it for an ordinary chronometer balance for arcs of motion of 180° and 540°, M. Phillips found that it would amount to a difference of about 11 seconds in 24 hours, losing that much in the long arcs. The effect can be diminished somewhat by giving to the rim of the balance the greatest thickness which a proper regard for the conditions necessary for temperature adjustment will permit.

b. Effect of the inertia of the spring.

Again, the factor M under the radical in the equation is not constant for all arcs of vibration; it is affected by the inertia of the spring. E. Caspari has shown⁴ that it causes acceleration of the short arcs, that this acceleration is proportional to the square of the difference in the arcs, and, for a given length of spring, to the fourth power of the radius, and that its effect would be six times greater in a spring of pure gold than in one of steel.

Further on we shall examine the eccentric motion of the spring, as one of the factors affecting its isochronism, and we shall also see that this factor has a decided influence on the rate of watches in vertical positions. Incidentally, I may observe that the effect of the inertia of the balance spring is relatively greater in watches than in ship chronometers, for the greater weight and diameter of the balance in the latter acquire a force or power to overcome minor disturbances relatively greater than that of the small balances in watches.

4. Disturbing Factors that exist in conditions outside of the Balance and Spring.

a. Resistance of the air.

One of the factors affecting the isochronism of the vibrations of the balance is the resistance of the air. In watches the disturbance arising from this cause is of

³ Recherches sur les chronomètres, note B.

⁴ *Ibid.*, note C.

⁵ *Ibid.*, p. 30. L. Lossier, in *Etude sur la théorie du réglage*, Geneva.

little importance. In ship chronometers it is greater. This is shown to vary as the square of the velocity and tends to retard the long arcs. No adequate means have ever been found for the elimination of this cause of disturbance, and the only remedy we possess so far is in a relative isochronal adjustment of the balance spring.

b. Influence of the impulse in the chronometer escapement.

It may not be generally known to watchmakers that the impulse communicated to the balance of a watch or chronometer, whatever the kind of escapement, ought to take place at the moment when the balance spring is in its state of equilibrium or rest, *i. e.*, when it is under no tension either one way or the other. If this is not the case, if the impulse is communicated before the spring has arrived at its state of rest or after, the effect will be to accelerate or retard the vibra-

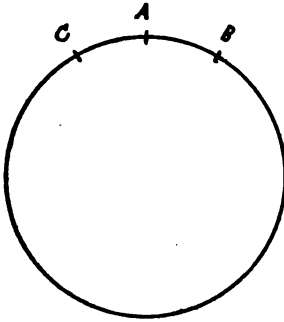

tions, and this acceleration or retardation is greater in proportion for short arcs than for long ones. In order to illustrate this, imagine a circle, Fig. 1, in which the balance moves, and let A be the point in that circle at which the balance spring comes to its state of rest. If the balance were in motion without contact with the escapement, it would perform a series of oscillations from one side to the other of the point A of equal duration, supposing the spring to be isochronal, but decreasing in arcs, owing to the friction at the pivots and the resistance of the air. Suppose now that an impulse is given to the balance at every other vibration, as is the case in the chronometer escapement, equal in intensity to the force lost or absorbed by friction at the pivots and the resistance of the air, and suppose that this impulse is communicated to it exactly at the point A, its velocity would be increased by a given quantity; its motion would be continued as if it had arrived at the point A with a velocity exactly equal to that with which it leaves it; its arc only would be affected, but not its time. Its return

vibration, during which it receives no impulse, would be of the same extent of arc diminished only by the amount of force absorbed by friction between the two successive impulses, but the isochronism would not be disturbed.

But suppose now that this impulse is communicated to the balance at the point B, before the spring reaches its state of rest. The entire oscillation from its beginning to the time when the balance arrives at B is performed with a given velocity which, preceding as it does the communication of renewed impulse, is independent of it. But at B the impulse is added to the force still resident in the spring and consequently the arc B A is performed with a greater velocity than the portion of the descending vibration immediately preceding it; in other words, in less time. The duration of the first half or descending oscillation is therefore shortened by the impulse and this shortening is greater or less in amount according as B is further or nearer the point A or state of rest of the spring. Arrived at A, the balance will complete the other half or ascending vibration in the same time as if there had been no impulse, since the spring is assumed to be isochronal. Likewise the duration of the return vibration, which takes place without impulse, is not altered. But the duration of the two complete oscillations is shortened by the amount which the increase of the velocity at B has caused the arc B A to gain.

Suppose, however, that the impulse takes place when the balance arrives at C, after the spring has reached its state of rest. If the impulse had been given at A the balance would have performed the arc A C with a greater velocity than it really had; it has therefore taken it a longer time to travel over this arc; whence results a slowing of that half of the oscillation by the amount which the balance lost in traveling over the arc A C before receiving renewed impulse. The impulse at C affecting only the extent of the arc, the rest of the oscillation between two successive impulses is of the same duration, the spring being supposed isochronal.

In order that the impulse in the chronometer should be given as near as possible at the moment when the spring reaches its state of rest, the impulse pallet, when the balance is at rest, should stand on the line of centers

between balance and escape wheel; indeed, M. Lossier, who, in the work already quoted, has treated the matter with all the mathematical accuracy required to prove it, shows that it should stand a trifle beyond the line of centers towards the exit tooth and for the following reasons: When the balance is moved a trifle from the position in which the spring is at rest towards the entering tooth and allowed to return, it will come to rest a little before it reaches the exact position which it occupied before it was disturbed. This is due to the absorption, by friction at the pivots, etc., of a certain amount of the force of the spring by reason of which the latter reaches its state of rest a little earlier. By shifting both impulse and unlocking pallet a little towards the exit tooth, or turning the hairspring collet in the reverse direction, which will cause the unlocking to occur a little earlier in the course of the oscillation of the balance, this difficulty can be met and the effect remedied; in part only, however, for it must be apparent that the quantity by which the displacement of the point of rest occurs from this cause differs for different arcs, it being least when the arcs of vibration are greatest and largest when they are the least in extent; hence also the variations in the rate of a chronometer, as between long and short arcs arising from this cause.

There is a further reason for placing the impulse pallet a little beyond the line of centers towards the exit tooth when the balance is at rest; for it may be observed that the impulse is not instantaneous, but continues over a certain arc of motion of the balance, and the line of centers is not dividing the impulse angle equally, because, by reason of the inertia of the wheel and the velocity of the balance when passing the entering tooth, the drop of the latter on to the face of the impulse pallet is longer than when it leaves the impulse pallet to drop on the locking jewel, thus reducing the impulse before the line of centers.

It is assumed by Caspari and others that to this factor may be ascribed, at least in part, the acceleration observable in the rate of chronometers as they grow old,⁶ basing his assumption on the fact, as he says, that

⁶Recherches sur les Chronomètres, p. 32.

“watchmakers are in the habit of producing the impulse “before the spring reaches its state of equilibrium, in “which case the short arcs would be accelerated, and the “chronometer, by diminution of its motion caused by the “age of the oil, etc., would gain.” But this assumption is based on a mistake, at least in 99 out of 100 cases, for, on the contrary, watchmakers and makers of chronometers, too, are in the habit of placing the impulse pallet so that when the balance is at rest it stands nearer the entering tooth than the line of centers, in which case the impulse is communicated to the balance after the spring has reached its state of rest, sometimes by nearly the whole amount of the impulse angle, which, according to the preceding reasoning, would tend to retard the short arcs. Moreover, the unequal partition of the impulse before and after the line of centers caused by friction, as well as by the inertia of the wheel, both causing it to occur after the spring has reached its state of rest, would be a cause for the losing in rate of the short arcs; hence this cannot be the cause of the observed acceleration of chronometers.

c. Influence of the impulse and unlocking in the lever escapement.

In the lever escapement, as a necessary consequence of its mechanical action the impulse is by construction unequally divided by the line of centers and therefore also unequal before and after the state of rest of the spring, supposing the latter to occur when the jewel pin is on the line of centers, and the escapement is “in beat,”—in watchmakers’ parlance—for, the lifting angle of the descending half of the oscillation of the balance is diminished by the angle of locking while that for the ascending one remains whole. Suppose, for instance, an escapement with 10° lever motion, $1^\circ.5$ of which is taken up by the locking. If the relation between the acting length of the fork and the distance of the impulse jewel from the center is as 4.5:1, the total lifting angle on the balance would be $4.5 \times 10^\circ = 45^\circ$, or $22^\circ.5$ on either side of the line of centers. But the impulse angle pertaining to the descending arc or that portion which takes place before the line of centers is diminished by the angle which is spent in unlocking, viz.: $1^\circ.5 \times 4.5 = 6^\circ.75$, leaving only $15^\circ.75$. The amount of impulse communicated

before the line of centers is therefore diminished while that communicated after the line of centers remains whole.

In addition to the unequal division of the impulse in the lever escapement before and after the line of centers, causing a loss of rate in the short arcs, it must be born in mind that the shock to the balance caused by the unlocking is of the nature of a resistance to its motion and tends to retard it to a more serious degree than the unequally divided impulse. M. Lossier has shown that both of these factors tend to retard the short arcs.

d. Influence of the regulator pins.

We shall presently examine more closely under what conditions the isochronism of the balance spring is possible in practice. We shall then see what use we can make of the regulator pins. For the present let us assume that a spring is isochronal without the regulator, and we may ask the question: What will become of its isochronism when the latter is added? It will not be difficult to show that it may under given conditions materially interfere with it or even wholly destroy it. In the first place, the addition of the regulator will shorten the active length of the spring and change the relation of its terminal pinning which, we shall see further on (5), will change its rate between long and short arcs.

But suppose that the isochronism of the spring exists with the regulator on and that we open the pins a trifle; what will be the effect? It will make the active length of the balance spring longer and the watch will go slower; not only that, but it will change the rate between the long and short arcs; for, suppose the pins are open so that for arcs of motion of the balance below 180° the coil between them does not touch either of the pins, it being exactly in the middle between them when the balance is at rest. The result will be that the arcs below 180° are performed with the full length of the spring from stud to collet, while the active length for arcs above 180° will commence more nearly from the pins. This will make the short vibrations very much slower than the long ones, and the effect will be manifest all along the arcs in variable rate. My own experience is that such a condition in the regulator pins will cause the middle arcs be-

tween 180° and 540° to gain, while we will have a loss in both extremes.

Suppose now, however, that when we open the pins the first coil of the spring does not lie exactly in the middle between them when the balance is at rest, and suppose it leans against one or the other in such a way that it requires a motion of the balance of 360° to lift it away from it; the length of the spring for arcs below that will now commence from the pins, while for arcs greater than that it will commence more nearly from the stud. The short arcs will in reality now be performed with a shorter spring than the long ones, and the watch will gain in the short and lose in the long ones, an effect exactly the reverse from that in the preceding example. We have in these two examples diametrically opposite results produced by the opening of the regulator pins alone, and between them are the means for an endless variation of results which the workman may take advantage of to suit particular cases. The most frequent and most fruitful cause of disorders in the performance of watches, the manipulation of the regulator pins, when intelligently done is the simplest and readiest means for correcting them.

e. Effect of friction as bearing upon the isochronism of the spring.

It would seem as though in any discussion of the problem of adjusting, and particularly as affecting the isochronism of the vibrations of the balance, friction would come in for a large share of our attention. No doubt it plays an important part among the various forces acting as disturbing causes in the result of our work. Notwithstanding this, however, I shall pass it with but incidental notice, mainly for two reasons: in the first place, my method of investigation, as will be seen, enables me to get the sum of the results of all the factors without the necessity of determining the part each of them plays separately; in the second place, friction, or the part it plays in the problem of adjusting at least, is not well understood to this day. M. Lossier says on this head: "The role of friction in horology has been "studied much and often discussed, and yet up to date

⁷ Etude sur la théorie du réglage.

“the question is not clearly settled. In spite of the very “remarkable works published on the subject, there still “remain obscurities. This arises from the fact that, in “horology, and particularly in the study of the functions “of parts so small and delicate as balance pivots and “pivots of the escapement, friction pure and simple, con- “sidered as a resistance to the sliding of two hard sur- “faces upon each other, is complicated by the adhesion “due to the interposition of lubricants.” We may, how- ever, state what are well ascertained laws of friction, as bearing upon the subject of adjusting. These are: First, *that it is directly proportional to the radius of the pivots, to the weight of the balance, and to the arcs of vibration of the balance.* In the last case it is more particularly the *work* of friction that is meant, rather than friction simply as a resistance to motion. Second, *that it is independent of the extent of the surfaces in contact and of the velocity of the balance.*

When from any cause, such as the thickening of the oil or the wearing of the pivots, friction increases, it will diminish the arcs of vibration, and this, in turn, may cause acceleration or retardation of the rate, according as the isochronism of the spring is defective in one or the other direction; but it may be stated that in general, friction as a resistance to motion will cause retardation, and that this effect increases as the arcs of motion diminish in extent. The subject of friction in relation to adjusting and to horology generally is most ably treated in the work of M. Lossier, already quoted, as well as by M. Grosclaude, in the “*Journal Suisse d’Horlogerie*,” vol 8 and 9, to which I must refer the reader for a closer study.

5. Isochronism of the Flat Spring.—We will now examine more particularly conditions that make practical isochronism attainable, and we will commence our work by an investigation of the laws that govern the movement of the ordinary flat spring without so-called theoretical terminals. For this purpose I shall introduce the reader to a series of experiments which I trust will aid us materially in our undertakings.

If we examine a flat spring without terminal curves during its winding and unwinding as the balance vibrates,

we find that its radial motion is wholly on one side, O B, Fig. 2. This is because the stud, to which the outer end is fixed, lies in the same horizontal plane as the spring itself and is itself fixed to the balance bridge or frame of the watch, by reason of which the spring has no chance to expand in that direction. The result is, first, a variable pressure on the balance pivots, and second, a constant oscillation of the center of gravity of the spring on the line A o B. The first of these effects is unimportant, the force of the balance being such that the pressure of the spring against the balance pivots, as a resistance, is as nothing compared to it. The second we shall deal with hereafter, when we come to position adjustment. There is, however, a third effect resulting from this eccentric

FIG. 2.

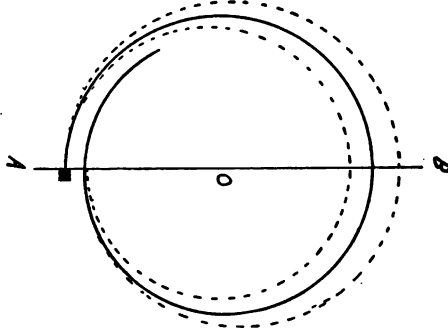

motion which is of greater importance and which we shall now examine. This is an effect of torsion, so to speak; an additional circular impulse, now adding itself to the force of the spring and again counteracting it. To make this plain, let us suppose a flat spring, Fig. 3, composed of a certain number of whole coils, plus a part of a coil, pinned to the stud S and to the collet at P. When the balance is set in motion this spring, by reason of the fixity of the stud, will exert an effort of pushing and pulling at the circumference of the collet to which the inner terminal is fixed. Precisely the same effect is produced, and we may acquire a more realizing sense of it, if instead of setting the balance in motion, we move the stud from S to S', or to S''. In the first instance the moving of the stud will have the effect of turning the balance over an

arc P a, winding up the spring, and in the second over an arc P a', unwinding it, translating itself into a circular force added to the force of the spring.

It will readily be seen that this effect must vary with the angular distance at which the ends of the spring are pinned. It is greatest when the two ends are pinned at right angles to each other—i. e., at 90° , or 270° , and least when they are pinned on the same side or radial line, or on opposite sides. We shall presently see the difference in the effect upon the isochronism of the spring, and we shall also see that the effect varies with the arc of motion of the balance for one and the same angular distance of pinning.

FIG. 3.

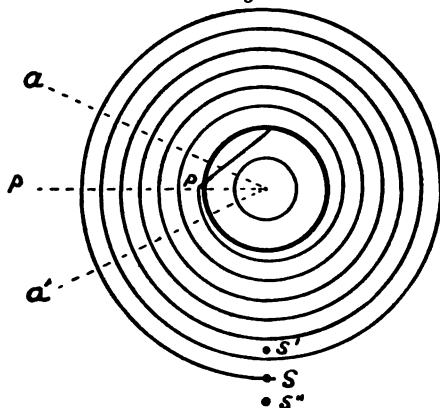

It is impossible to convey a clear idea of the complicated function of this factor by mere verbal statement, but I have succeeded, through the experiments that follow, in eliciting and coördinating its effect on the rate of watches, in a manner beyond reasonable doubt. I may add, too, that those of my readers who are familiar with mathematical reasoning will find the subject ably discussed by M. Lossier, quoted heretofore, but not more positively demonstrated, as to results, than it will be found here.

Having fitted a flat spring to a ship chronometer prepared to run by weight, as stated heretofore (Intr.), I started with a certain length of spring and given angular distance of the pinning points, and observed its rate dur-

ing some interval of time, not necessarily in all cases the same, first with arcs of motion of the balance of 90° , then of 180° , 270° , 360° , 450° and 540° , adding weight to the motive power when I desired to increase the extent of the arcs. I then calculated the rates obtained from the separate arcs of motion for the same interval of time, viz.: four hours, and reduced them to the mean rate of all the arcs.

The result being recorded, I cut off one-eighth of a coil, or 45° , making the spring that much shorter and the angular distance between the terminal pinning that much less, and proceeded with the new terminal pinning as before, and so on, for each 45° difference in the angular distance of the pinning, until a whole coil of the spring was used up, making thus eight separate experiments, each experiment divided into six by changing the arcs as above and reducing the rates to the mean. This, it will be seen, gave me the means of comparing the results with a standard common to the whole series of experiments. I repeated the series with succeeding coils of the same spring, as well as with other springs, not always obtaining the same result quantitatively under similar conditions, but substantially the same characteristically. For our present purpose one only of the series will suffice.

I may add that every precaution was taken to guard against accidents or outside influences of any kind that might interfere with the results. The chronometer was running under a glass globe, dial down, so that I could observe the arcs of motion of the balance, while a mirror placed at a convenient angle under the dial enabled me to see the time indicated without turning it or handling it in any way during one set of experiments. Table I gives the result of such a series. In the first vertical column are arranged the angular distances of the terminal pinning in one and the same coil of a spring, the letter N signifying the number of whole coils, and the plain figures the angular differences in the terminal pinnings, while the figures on the horizontal lines, opposite the respective pinnings, represent the rates, or, more properly speaking, the corrections to the rates for that pinning in the different arcs of motion, the latter being indicated by the horizontal line of figures over the top of the table.

TABLE I.

Showing variation of rate in horizontal position with a flat spring without theoretical terminals, for eight different terminal pinnings, under six arcs of vibrations.

The sign — signifies that the rate is fast, and the sign + that it is slow.

Terminal Pinning.	90°	180°	270°	360°	4.50°	5.40°
	Secs	Secs.	Secs.	Secs.	Secs.	Secs.
N Coils + 315°	-10 33	- 9.08	-6 38	+1.99	+8.6	+15.2
N " + 270°	-10 31	- 8.39	-3 36	-0 09	+8.78	+13 38
N " + 225°	- 9 57	- 7 00	-1.53	+1.61	+6.24	+10.22
N " + 180°	- 7.56	- 3 81	-1.32	+1.97	+3.88	+ 6.85
N " + 135°	- 8.17	- 4 14	-1 58	+1.97	+4.19	+ 7.72
N " + 90°	- 9.51	- 7 09	-2 13	+2.21	+6.78	+ 9.73
N " + 45°	-10.73	- 8 76	-5.16	+1.39	+9.26	+13 98
N Coils.	-11 53	-10.19	-5 37	0.21	+9.72	+17 58
Mean Error of Isochronism.	- 9 71	- 7.31	-3.35	+1.35	+7.18	+11.83

Before analyzing this table, and in order to convince the reader of the trustworthiness of the figures and therefore of the value of the results of the experiments, it may be well to show, by example, the process by which they have been obtained.

In the first place, the comparison with standard time (a fine English astronomical clock controlled by daily time signals) was made by what is known as "coincidence of beats." The chronometer beating half seconds, whenever its beat coincided exactly with the beat of the clock, the difference between their time was exactly a number of whole half seconds, which could be ascertained with sufficient accuracy. In the next place, whenever a new series of experiments was commenced either the state of the chronometer, *i. e.*, the time indicated on its dial, was taken at coincidence of beats, or it was started exactly on the time of the clock by synchroniz-

ing the beats. Then, when comparison was made the clock's time was recorded together with the time of the chronometer. For the sake of greater accuracy and to avoid possible errors of observation, several coincidences were thus recorded one after the other as rapidly as they occurred and the mean of them taken.

Let us take, for example, the series of experiments made with the angular distance between terminal pinning of $N + 315^\circ$, recorded on the top horizontal line of table I:

H. M. Sec.					H. M. Sec.							
At 7	48	00	A. M.	the	chronometer	was	set	to	coincide	with	the	clock.
At 1	40	44	P. M.	chronometer	indicated	12	11	21				
" 1	42	00	"	"	"	12	12	18.5				
" 1	43	12	"	"	"	12	13	11.5				
" 1	44	24	"	"	"	12	14	6				

Adding both sides and dividing by four we find that

H. M. Sec.					H. M. Sec.			
At 1	42	35	P. M.	chronometer	indicated	12	12	44.25
In other words, in 5 hours, 54 minutes and 35 seconds the chronometer had made only 4 hours, 24 minutes and 44.25. Reducing the time of the clock to hours and fraction and that of the chronometer to seconds we have: In 5.909722 hours the chronometer made 15884.25 seconds, and dividing the latter by the former we find the rate of the chronometer per hour was								
= 2687.82 seconds.								

In order to avoid dealing with larger figures than was necessary for my purpose the rate of the chronometer in each experiment was calculated for four hours only instead of for twenty-four; multiplying this number, therefore, by 4 we have for the rate of the chronometer in four hours:

$$= 10751.29 \text{ seconds.}$$

This was its rate for the terminal pinning of $N + 315^\circ$ and when running under arcs of motion of 90° . When its rate for all the other arcs with the same terminal pinning was obtained in the same way the result was as follows:

For arcs of	90°	its rate was	10751.29	seconds in	4 hours.
" "	180°	" "	10750.02	" "	" "
" "	270°	" "	10747.32	" "	" "
" "	360°	" "	10738.95	" "	" "
" "	450°	" "	10732.34	" "	" "
" "	540°	" "	10725.74	" "	" "

Adding the results and dividing by 6, we have for the mean rate of all the arcs:

$$= 10740.94 \text{ seconds.}$$

Subtracting this mean from the rates of the several arcs, and observing that when the number from which the mean is to be subtracted is greater than the mean, the sign — must be placed before the remainder, and conversely the sign + when the number is smaller we have as corrections to the mean rate:

For arcs of	90°	=	—	10.33	sec.
" "	180°	=	—	9.08	"
" "	270°	=	—	6.38	"
" "	360°	=	+	1.99	"
" "	450°	=	+	8.60	"
" "	540°	=	+	15.20	"

These are the figures occupying the top horizontal line opposite the terminal pinning of N coils + 315°. They represent the corrections to the mean rate of the chronometer for the different arcs of motion of that pinning. In like manner the data for each angular distance of pinning in the table have been obtained.

It will be seen that in reducing the rates of each separate terminal pinning to the mean I have established a line of comparison for the whole series of experiments, around which they are grouped, which reveals their relation and differences. I have also disencumbered the work of the long numbers, showing only the actual differences of rate between the several arcs and terminal pinnings, which was what I desired to ascertain.

It may be proper to state that absolute quantitative accuracy is not claimed for the results. In the first place, the dropping of endless fractions makes a slight difference when observations are taken at short intervals of time and the result multiplied. In the second place, taking the time at the coincidence of beats, although the most accurate method known, still leaves a chance for slight errors in that the observer is liable to mistake the

exact moment when the coincidence does take place. Taking, for instance, the example we have followed above, we see that the chronometer when running with arcs of 90° was losing on mean time by more than 0.25 sec. per second; the exact amount being 0.2534 sec. If it had been losing exactly 0.25 sec. for every second of the clock, there would have been a coincidence every other second, the chronometer beating half seconds; as it is, however, there was a more or less close coincidence at the second, fourth, sixth, tenth, twelfth and sixteenth seconds after synchronizing it, and then not again until the seventy-fifth second, when the coincidence was almost exact. It will be seen by inspection that the interval between successive observations in the example was in the neighborhood of that number of seconds. Absolute quantitative accuracy was, moreover, not so essential, so long as the characteristic differences between the different terminal pinnings and arcs were what they are. To ascertain these differences was my object, and these, I claim, the results of the experiment establish beyond a doubt.

But, returning to the table and noting the bottom horizontal line of figures called "mean error of isochronism," we observe that the spring is very far from being isochronal; in fact, there is a difference of 21.54 secs. in the rate between the longest and shortest arcs. Leaving, for the moment, the discussion of this want of isochronism and its cause, let us see what we can elicit from the results, as to the effect due to difference in angular distance of terminal pinning.

If we subtract the mean error of isochronism, or the bottom horizontal line of figures, from the results obtained by the separate terminal pinnings, we eliminate that quantity from the table, *i. e.*, we take it out of it and that which remains of the separate results after it has been taken out must be due to difference in terminal pinning. This will be clear to the reader after a little reflection; for, it is evident that this great error of isochronism in the spring is due to a cause other than that of difference in terminal pinning; also, that differences due to terminal pinning, if there are any, must be included in the general results. But terminal pinning being the only variable condition in the whole series of experi-

ments, the effect of it must figure as the prominent feature in the results. To eliminate, therefore, the mean error from the general results will not affect or change that which is due to terminal pinning.

For the sake of a clearer understanding, let us perform the process of elimination for one of the vertical columns in the table, leaving the others for the reader to verify. Let us take, for instance, the column headed by 90° . This column represents the rate for all the eight different terminal pinnings for the arc of motion of 90° . The mean error for this column is -9.71 secs. This is obtained by adding all the quantities in that column and dividing the sum by 8, the number of different terminal pinnings. To eliminate a quantity is the same as to subtract it. To subtract one quantity from another algebraically we change the sign of the subtrahend and add it to the quantity it is to be subtracted from. Changing -9.71 to $+9.71$ and commencing the addition at the top of the column, we have:

$$\begin{array}{r}
 + 9.71 \text{ added to } - 10.33 = - 0.62 \\
 + 9.71 \text{ " " } - 10.31 = - 0.60 \\
 + 9.71 \text{ " " } - 9.57 = + 0.14 \\
 + 9.71 \text{ " " } - 7.56 = + 2.15 \\
 + 9.71 \text{ " " } - 8.17 = + 1.54 \\
 + 9.71 \text{ " " } - 9.51 = + 0.20 \\
 + 9.71 \text{ " " } - 10.73 = - 1.02 \\
 + 9.71 \text{ " " } - 11.53 = - 1.82
 \end{array}$$

Performing this operation on all the other columns by subtracting from the quantities in each the mean error proper to the column under which it stands, we get the results contained in Table II. and we have eliminated the mean error of isochronism from Table I., and Table II. contains that portion of the error due to difference in terminal pinning only.

Observing now the meaning of the algebraical signs $+$ and $-$ as indicated at the top of the tables, we see how the rate changes from fast in the short arcs to slow in the long ones and from slow in the short arcs to fast in the long ones as we pass down the columns from one terminal pinning to the other, and we observe that the passage from $-$ to $+$ and from $+$ to $-$ occurs between the pinning $N + 270^\circ$ and $N + 225^\circ$, and between $N + 90^\circ$ and $N + 45^\circ$, indicating that at some

TABLE 2. (See Plates I and II.)

Deduced from Table 1 by eliminating the mean error of isochronism, and showing the part of the variations due to difference in terminal pinning.

The sign — signifies that the rate is fast, and the sign + that it is slow.

Terminal Pinning.	90°	180°	270°	360°	450°	540°
N Coils + 315°	-0.62	-1.77	-3.03	+0.64	+1.42	+3.37
N " + 270°	-0.60	-1.08	-0.01	-1.44	+1.60	+1.55
N " + 225°	+0.14	+0.31	+1.82	+0.26	-0.94	-1.61
N " + 180°	+2.15	+3.50	+2.03	+0.62	-3.30	-4.98
N " + 135°	+1.54	+3.17	+1.77	+0.62	-2.99	-4.11
N " + 90°	+0.2	+0.22	+1.22	+0.86	-0.40	-2.10
N " + 45°	-1.02	-1.45	-1.81	+0.04	+2.08	+2.15
N Coils.	-1.82	-2.88	-2.02	-1.56	+2.54	+5.75

point between these two sets of terminal pinnings would be a point, on either side of the center, at which the effect of terminal pinning, or, more properly speaking, torsion due to terminal pinning, would be zero. On the other hand, we see that the greatest difference in the rate, as between long and short arcs, occurs at the terminal pinnings of $N + 180^\circ$ and N number of coils, short arcs going slow in the first and fast in the second pinning and the reverse being the case in the long arcs.

To enable the reader to more readily comprehend the meaning of this I have succeeded in making the differences visible by illustrating Table 1 graphically on Plate I., using the quantities in the table as coordinates of curves. Spaces on the black horizontal lines represent arcs of motion, and distances above or below these lines, rates. For the sake of simplicity, the vertical ordinates are omitted. In order to make the contrast between the curves more apparent, I have grouped them so that opposite results come opposite the middle horizontal line, the two differing most from each other being in the middle, and slow rates or + quantities being plotted below the horizontal lines, and fast rates, or — quantities above them. In addition, the angular distances of terminal pin-

nings are stated by number and illustrated by figure to the left opposite the respective curves.

To further illustrate Table II., and particularly in order to locate the points in the spring of least interference by torsion, I have constructed Plate II., in which the quantities in the table are coördinated to a cricle. Here the curves follow, not the arcs as in Plate I., but the terminal pinning, *i. e.*, the quantities taken in vertical order of the columns instead of the horizontal, while differences in rate between the arcs of motion for one and the same terminal pinning are measured by radial distance. The heavy black circle represents mean rate, while + quantities are plotted outside and — ones inside of it. From this disposition it follows that, since the rate following the columns vertically passes from — to + and from + to — in the short arcs and from + to — and — to + in the long ones, the curves produced by the plotting of the rates must cross the circle at O variation, and that the points at which they so cross the circle must be points, as to terminal pinning, at which the difference in rate between long and short arcs is zero, and that, therefore, at these terminal pinnings the factor we have called torsion will least interfere with the isochronism of the spring.

If it be objected that I have not proved that the quantities tabulated in Table II. represent the error due to torsion, as affected by terminal pinning, alone, I freely confess to the force of the objection. But I have proved that whatever other causes may have been implicated in the results, torsion is one of them as governed by terminal pinning, and that it is the ruling cause. I am quite willing to admit that other disturbing factors have influenced the result, for I find anomalies in the rate of some of the terminal pinnings which I am unable to account for; but that, I venture to say, will not invalidate the general conclusion I have drawn. Again, the result is not as gratifying as might be desired. In Plate II. the curves do not cross the circle at the same point, showing that even at the terminal pinning shown to be the most favorable, the isochronism of the spring will lack perfection. The result may be affected by local conditions or by conditions that vary with different springs.

The rest of Plate II. may be expected to explain itself. If we draw a diametral line A B through the points in the circle nearest to which the curves cross it, we see that short arcs will go fast for terminal pinnings to the right of this line, and slow for those to the left of it, and contrariwise in the long arcs. This closely accords with the results obtained by M. Caspari touching the cylindrical spring that, "for a negative value of the cosin of the angle "of terminal pinning we have a gain in the long arcs and "for a positive value of the cosin of the terminal pinning "a loss in the long arcs."⁸

We also have a statement by A. L. Berthoud, a descendant of the illustrious F. Berthoud, in reference to cylindrical springs, as follows: "In every spring of a "helicodal or conical form, and in each coil, there are two "points of pinnings at which unequal arcs of vibrations "are isochronal. The position of these points of isochronism is N coils $+ 100^\circ$ and N coils $+ 260^\circ$. The points "at which long arcs gain lie between N coils $+ 100^\circ$ and " N coils $+ 260^\circ$. The points at which short arcs gain lie "between N coils $+ 260^\circ$ and $N + 1$ coil $+ 100^\circ$."

It will be admitted that the results of my experiments establish the general fact of this statement to be true for the flat spring also. One of the points of pinning for which Berthoud claims isochronism may be looked upon as identical; the other in my results, that lying between N coils $+ 45^\circ$ and N coils $+ 90^\circ$ differs somewhat in location from his, but not enough to admit of a doubt. Furthermore, it may reasonably be assumed as probable that the case would be somewhat different in a flat spring.

Of course, I should not be understood to claim that any balance spring will be practically isochronal by pinning the ends into collet and stud at the angular distance indicated in my experiments to be the points at which torsion affects its isochronism the least. That might be the case or it might not, the result depending on still other conditions presently to be examined. The spring, for instance, from which we have elicited the above results is seen to be very far from being isochronal at any of the points of terminal pinning. The nearest ap-

(8) *Recherches sur les chronomètres* 11e Cahier. Note E., p. 149.

proach to isochronism it made was in the result obtained with the terminal pinning of N coils $+ 180^\circ$, this being the pinning at which, as we have seen, the short arcs are performed the slowest; yet the difference between the longest and shortest arcs at that pinning was over 14 seconds. From among a number of examples of springs I have experimented with I have purposely selected this one for illustration in order to bring out that fact, and I shall show hereafter (6) what other conditions are necessary to be established in order to secure the isochronism of the movements of the balance.

I have experimented with cylindrical springs with results identical, almost, to the foregoing. Plate III., Fig. 1, exhibits graphically the results obtained from such an one, first without terminal curves and then with theoretical terminals. It would be superfluous to analyze these results, for it can be seen at a glance that they are, characteristically, the same as those obtained with the flat spring and no better. It may be worthy of note that at the terminal pinning of N coils $+ 270^\circ$, without terminal curves, it gave almost identically the same result as it did with theoretical terminals. The extraordinary variation, quantitatively, is due to the diameter of the spring, which I made purposely excessive in order to increase the effect I desired to study (3, b).

In like manner I have experimented with the flat spring made according to "Bréguet," with theoretical outside terminal. Table 3 exhibits the results of such a

TABLE 3.

Illustrating the behavior of a flat spring, so called "Bréguet," with correct outside terminal, for four different terminal pinnings, and under six arcs of vibration.

N. B.—The sign — indicates that the rate is fast, and the sign + that it is slow.

Arcs of Vibration.	90°	180°	270°	360°	450°	540°
N Coils.	+2.37	+0.34	-1.65	-1.13	-0.2	+0.27
N " + 90°	-3.18	+0.28	+0.76	+1.27	+1.37	-0.51
N " + 180°	-1.26	-0.52	+1.18	+1.34	+0.41	-1.12
N " + 270°	+2.05	-0.09	-0.3	-1.46	-1.56	+1.37

spring in four different terminal pinnings. This spring had served me for experiments in the flat before with results characteristically the same as those of the foregoing series. The changes in terminal pinning, after it was made into "Bréguet," were made by cutting off the inside and repinning into collet.

I have not thought it necessary to illustrate this table graphically, as the results are sufficiently plain to be readily understood after a study of Table 2. The first thing that will strike the reader in this table is that the variations of rate, both for differences in the arcs of motion and angular distance in pinning, are very much smaller, quantitatively, they having been calculated for the same interval of time; whereas characteristically, at least for arcs of 270° and upwards, they are just the same. A singular feature of the result is that for arcs of 180° and 90° the characteristic of the variations is just the opposite from what we have in Table 2 with a plain flat spring. As the outside terminal in this spring was a theoretical curve, it may be assumed that the characteristic variations of the rate are due, mainly, to the effect of the non-theoretical form of the inner terminal.

Whatever other value this last experiment may have, it furnishes proof that the application of correct terminals does improve the condition of isochronism of the spring; but at the same time also that the single Bréguet curve, however theoretically correct, does not remove all the disturbance arising from torsion. I regret to state that I have not made the experiment with a flat spring terminating both inside and outside in theoretical curves. These experiments are very long and tedious, requiring a great deal of time and leisure, which are not always at our command. Moreover, as a matter of fact, I assumed with others, *a priori*, at the time I made these experiments, that theoretical curves would obviate all the errors arising from that source; I could therefore learn nothing by experimenting with them further than proving this fact, and that was not what I was particularly after. I will, however, say that I have since come to the conclusion, on the strength of experiments subsequently made, which I shall deal with when we come to the ad-

justment to position, Chapter II., that theoretical curves, though both inside and outside terminal be such, will not wholly remove the error in question.

6. Isochronism as Affected by Varying the Total Length of the Spring.—We have seen in the foregoing experiment, Table I., that the spring there used was very far from being isochronal. In fact, by consulting the figures giving the mean error of all the terminal pinnings, we find that the difference in the rate of the chronometer between the longest and shortest arcs was 21.54 seconds, calculated for four hours' interval of time only; consequently for 24 hours this difference would be 129.24 seconds, going that much faster in the short arcs. It is impossible to account for this difference by the effect of centrifugal force upon the balance alone (3, a). Furthermore, we shall presently see that with another spring, when all the conditions save one were just the same, there appeared no such discrepancy. The question arose: To what is it due?

We have a statement by Pierre Le Roy, quoted by nearly every author who has treated the subject, the ground for which he is said to have reached by experiment, that, "in every spring of a *sufficient length*" (the italics are mine) "there is a certain length at which all the vibrations, long or short, are isochronal. This length ascertained, if the spring is made shorter, the LONG vibrations will be performed quicker than the short ones. If, on the contrary, we make it longer, the short vibrations will be made in less time than the long ones." Basing myself on this assertion, I concluded that the spring I had been experimenting with was too long, since it caused the short arcs to be performed much quicker than the long ones. The reader may imagine my surprise when I found that exactly the contrary effect followed; for, on making it shorter, the short arcs were performed still faster. In making the spring shorter, however, I was careful to cut off a whole coil at a time, for, if I had cut off less, or more, the result would have been complicated and made unreliable by the effect of a change in the angular distance in terminal pinning.

The experiment that follows was made in the same way as preceding ones. The comparisons were made at the

coincidence of beats and the result for each arc of motion computed for the same interval of time. The length of the spring at starting was 11.5 coils and the difference in the rate of the chronometer as compared between the arcs was as follows:

For arcs of	90°	it had a rate of	23.6	seconds.
" "	180°	" "	21.7	"
" "	270°	" "	16.7	"
" "	360°	" "	13.4	"
" "	450°	" "	4.6	"
" "	540°	" "	0.	"

To make the result visible at a glance, I give the differences of the rate only as compared with the rate for the longest arcs. After cutting off a coil on the outside and repeating the trial, it gave the following:

For arcs of	90°	a rate of	31.	seconds.
" "	180°	" "	30.2	"
" "	270°	" "	25.1	"
" "	360°	" "	18.4	"
" "	450°	" "	9.2	"
" "	540°	" "	0.	"

With a second coil cut off so that its total length was then only 9.5 coils it gave the following:

For arcs of	90°	a rate of	37.3	seconds.
" "	180°	" "	37.8	"
" "	270°	" "	31.	"
" "	360°	" "	24.2	"
" "	450°	" "	14.2	"
" "	540°	" "	0.	"

Thus we see that every time the spring was made shorter the short arcs were performed quicker.

I fitted another spring of the same strength of wire and the same number of coils, making the outside terminal into a Bréguet curve of correct form. This spring I shortened from the inside also by cutting out whole coils at a time, making sure that it was well centered every time after repinning. The first result was as follows:

For arcs of	90°	its rate was	15.7	seconds.
" "	180°	" "	14.	"
" "	270°	" "	10.9	"
" "	360°	" "	7.9	"
" "	450°	" "	3.0	"
" "	540°	" "	0.	"

After cutting one coil out of the center it gave:

For arcs of	90°	a rate of	19.7	seconds.
" "	180°	" "	19.3	"
" "	270°	" "	14.5	"
" "	360°	" "	11.1	"
" "	450°	" "	5.3	"
" "	540°	" "	0.	"

After cutting out a second coil it gave:

For arcs of	90°	a rate of	26.4	seconds.
" "	180°	" "	25.6	"
" "	270°	" "	18.7	"
" "	360°	" "	15.5	"
" "	450°	" "	9.	"
" "	540°	" "	0.	"

I cut out a third coil, with the following result:

For arcs of	90°	it gave a rate of	40.6	seconds.
" "	180°	" "	36.2	"
" "	270°	" "	30.	"
" "	360°	" "	21.4	"
" "	450°	" "	12.6	"
" "	540°	" "	0.	"

Thus the result was the same every time the springs were made shorter, whether the cutting off was done on the inside or the outside of the spring—*i. e.*: it made the short arcs go relatively faster, and apparently at an accelerating rate as the spring was getting shorter.

Here, then, I met with a surprise. All the books I had ever read on the subject claimed that shortening a spring will make the *long* arcs go relatively faster. Even Ferdinand Berthoud, the greatest of authorities in experimental horology, claims it, and seemingly proves it by reasoning.⁹ Could it be that these authorities are all mistaken; that they merely copied statements from each other without verifying the correctness of them, or that their results were complicated and vitiated by some factor not understood by them? Could they have been led astray by the effect of changes in the angular distance of terminal pinning? Certainly, my results prove the exact opposite from their statements—*i. e.*: that shortening a spring *by whole coils at a time* will make the short arcs go relatively faster.

(9) *Traité des horloges Marines* 142-144, Paris, 1773.

Naturally, my next step was to try a longer spring. Accordingly, I made a new one, of the same thickness of wire, but longer by four complete coils. The result with this spring, under the same test as that made with the preceding springs, was as follows:

For arcs of	90°	the correction was	+	3.6	seconds.
" "	180°	" "	—	0.28	"
" "	270°	" "	—	0.64	"
" "	360°	" "	—	0.77	"
" "	450°	" "	—	0.85	"
" "	540°	" "	—	1.04	"

Owing to the very small difference in the rates, the computation being for the same interval of time as in the previous examples, the rates are here reduced to the mean, so that the quantities must be considered as the corrections, and the sign + indicates that the rate was slow, and the sign — that it was fast.

It will be observed that this spring is very much nearer isochronal than those which served in previous examples; not only that, but it differs from them, in that the short arcs give a relatively slower rate than the long ones, a fact resulting wholly from the greater length of spring, all other conditions having remained the same.

After cutting off one coil and taking care to repin it at exactly the same angular distance as before the result was as follows:

For arcs of	90°	the correction was	+	2.26	seconds.
" "	180°	" "	—	0.80	"
" "	270°	" "	—	0.42	"
" "	360°	" "	—	0.41	"
" "	450°	" "	—	0.39	"
" "	540°	" "	+	0.	"

Here again we see that shortening the spring has made the short arcs go relatively faster. The proof is such that it is needless to cite other examples, of which I have a multitude. I am sure the assertion of the authorities was made on mistaken ground, or on data not fully understood by them. I am sure that shortening a spring by whole coils at a time will make the short arcs go relatively faster. If, however, a spring were made shorter, not by whole coils at a time, but by a portion of a coil, then it might happen, as we have seen, that the

contrary may result; but this would be the effect of a change in the angular distance of terminal pinning.

All three of the springs here tested were made of the same size wire, and all other conditions under which the experiments were made were exactly the same.

I desired to know what would be the effect if, instead of making the spring longer, it was made thinner. Accordingly I made a spring of the same length as the preceding one, but considerably thinner. On testing it in the same way it gave the following results, the rates being computed for 24 hours:

For arcs of 180°	it	lost	24.	seconds
" "	270°	"	15.	"
" "	360°	"	8.	"
" "	450°	gained	4.	"
" "	540°	"	5.7	"

the difference being nearly 30 seconds in 24 hours between the longest and shortest arcs, going that much slower in the short ones.

And now, what conclusion are we to draw from these results? Plainly this, that, besides proper angular distance between the terminal pinning, besides theoretical curves however perfect, there is still another factor which needs to be taken into account in the equation of the movement of the balance if it is to stand the test of practical isochronism, and that is the total length of the spring, its thickness being given or vice versa. In the statement of Pierre Le Roy quoted above I have drawn attention to the indefiniteness of the words, "sufficient length," by italicizing them. Mr. Phillips speaks of obtaining isochronism by means of terminal curves "combined with a *sufficient length* of spring."¹⁰ In order that the solution of the problem should be of practical benefit to the watchmaker it is necessary that this length be determined, and this mathematical analysis has failed to do hitherto. We have in this "sufficient" length a factor which enables us to obtain practical isochronism under almost any conditions; for, whatever the combined effect of any number of disturbing factors may be, provided they are inherent and not intermittent, we can always choose such a length

(10) *Le spiral réglant*, page 53.

of spring, combined with modifications of terminal pinning, that will correct them.

I may be permitted to point out an application of these results in a very important case. It is well known that in ship chronometers, owing to the effect of centrifugal force (3, a), as well as that of the inertia of the spring (3, b), the short arcs of vibration are always performed considerably faster than the long ones, *i. e.*: they will gain in the short arcs in spite of correct terminals in the spring. For this reason, perhaps more than for any other, many makers do not adopt these curves, but prefer, on the contrary, to sacrifice the good effect of them in order to obtain closer isochronism, which they can by causing suitable deformation of the spring with non-theoretical terminals. A better way would be to retain the correct terminals and then correct the error in isochronism by a suitable total length of the spring. It might be necessary, however, to change the weight or diameter of the balance in order to bring it to mean time; in other words, to adapt the balance to the spring instead of adapting the spring to the balance, as now practiced.

I may add that the isochronal condition of the spring, *i. e.*, whether the development of its force corresponding to angular deflection is strictly in arithmetical progression or not (2), is independent of the weight and diameter of the balance.

There is one factor which has not been taken into account in the foregoing experiments, which unquestionably affected the results to some extent, and that is the increased effect of centrifugal force; for, in making the spring shorter, the weight of the balance remaining the same, the vibrations of the latter were of necessity accelerated, and this would increase the effect of centrifugal force in the long arcs (3, a). But it is impossible that the results in the experiments should be due to this factor alone; for on the supposition that shortening a spring will make the short arcs go slower, as had been claimed by the authorities, there should come a time when the effect of shortening should balance that arising from increased centrifugal force whatever the time of the vibrations. But there was evidently no tendency in that direction.

I confess, however, that the experiments should have

been made under conditions avoiding this contingency, by weighting the balance to maintain it at mean time rate every time the spring was made shorter. Unfortunately this did not occur to me until some time afterwards, when the opportunity for repeating the experiments had gone by. Unless the latter should return, I will have to leave it to a successor, if there be still those who take an interest in the subject, to verify the results. In such an experiment the weight added to the balance should be placed near the arm; otherwise, if placed on the rim near the cut end, the result would be vitiated, for this would again increase the effect of centrifugal force in the long arcs.

7. Terminal Curves.—We have now arrived at a stage of our inquiry where we are naturally led to consider the effect, as well as the proper form of terminal curves. Professedly these are intended to obviate and correct the influences we have just considered, arising from the eccentric motion of the spring. Not, however, until about thirty-six years ago, when the learned engineer, M. Phillips, published his "Memoir on the Balance Spring," to which we have already referred (3), did watchmakers have any very definite knowledge as to the proper form to give these terminal curves. Before that time all attempts at their shape were mere gropings in the dark. Thanks to his labors, we know now exactly what their form should be. Not only that, but he furnished us the data which enables us to make them for any given spring. His investigations were limited principally to cylindrical springs, but the formula he established is equally applicable to the terminals of a flat spring.

The fundamental principle underlying the theory of terminal curves is, that the center of gravity of the spring, during arcs of vibration of any extent, should always remain on the center of the balance arbor.

In a cylindrical spring, in which the coils are circles and superposed one above the other, the main body of the spring is readily centered to the balance arbor; but it will not remain centered when in motion unless the terminals are properly shaped. On the contrary, if that is not the case, the spring when in motion will not only not vibrate concentrically, but may lose its cylindrical shape,

moving away from the center at the top on one side and towards the center at the bottom of the other. With terminal curves properly formed, the spring will move concentrically to the balance arbor during its expansion and contraction when in motion—*i. e.*, opposite radii of the spring will always be equal. This is the visible proof of the correctness of the curves. The same definition holds good in the flat spring, with correct terminal curves. It is, however, not sufficient in the flat spring that the outer end alone should be formed into a curve, for, however perfect that curve may be, it will not satisfy the condition of keeping the center of gravity of the spring on the center of the balance when in motion. Alike with the outer end, when not properly formed, the inner one, being in the form of a spiral, will cause eccentric motion of the balance spring, and therefore displacement of the center of gravity, side pressure and torsion. This may be readily observed by looking to the center of a flat spring when the balance is in motion. There will appear, besides the radial motion, a bulging out and crowding in of the coils on opposite sides, visible as far out as the middle coil. When, however, the inner end is also a curve of the proper form, this bulging and crowding will entirely disappear, at least so far as it can be detected by the eye.

I am not so sure as some authorities I have consulted, that correct terminals will entirely remove and remedy the influences we have been considering in previous paragraphs, though I am willing to admit that they will not only do away with most of them, but that without them no real isochronism can be obtained. We shall return to this point again with fuller demonstration.

Without attempting to give the process of reasoning by which M. Phillips arrived at his conclusion—which would be impossible without mathematics of too abstruse a character—and since the above plain English definition of the proper function of the curves is all that is necessary to enable the reader to judge of their degree of correctness, I shall content myself by stating the formula he gives, assisted by an illustration. This much, at least, seems necessary in any work treating on the subject.

The sole condition for the construction of the curves is that the center of gravity of the whole spring, the

curves included, shall fall on the center of the balance arbor. Let Fig. 4 represent a cylindrical spring; O its center; C A and C' A' the terminal curves, and C C' a section of the cylindrical portion of the spring lying between the points where the terminals commence on leaving the main body of the spring. The condition is fulfilled if the two curves C A and C' A' and the section of the main body C C' balance each other so that their common center of gravity falls on the center O. To this

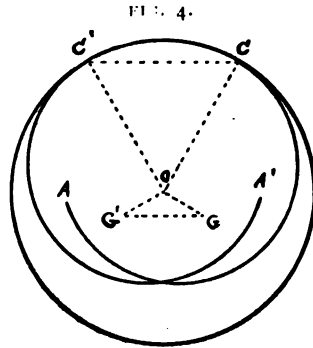

purpose it was necessary to locate the center of gravity of each of the curves. This M. Phillips shows must fall on a line O G, perpendicular to O C, passing through the point in the main body of the spring where the curve commences, and that the distance O G of this center of gravity from the center O should be:

$$\frac{R^2}{l}$$

in which R represents the radius of the spring, and l the length of the terminal curve. This is a very simple formula that will admit of an almost infinite number of curves different in form to suit every case. It is not necessary that the two curves should be symmetrically one above the other, as in the figure, nor that they should both be of the same form provided each fulfill the condition expressed in the formula. For the manner in which the formula is applied in the formation of curves, I must refer the reader to M. Phillips's "Le Spiral Réglant," Dunod, Quai des Augustines, Paris. But the workman into whose hands this modest treatise may fall will probably never be called upon to use the above formula, or to construct new curves. This has all been done for him, and for nearly every case that may possibly arise. On Plates XI. and XII. will be found a collection of

twenty-five curves, in eight different sizes of springs, covering all the sizes occurring in watches for both cylindrical and flat springs. They are taken from a little brochure published by E. James and J. Golay, both professors at the Horological School in Geneva, Switzerland, calculated and drawn by them for the use of the school, and others who adjust watches. I shall give the necessary instruction for using them when we come to the practical part of this work. Besides these curves, that shown in Figs. 5 and 6, is a curve practicable in all cylindrical and most of the flat springs;

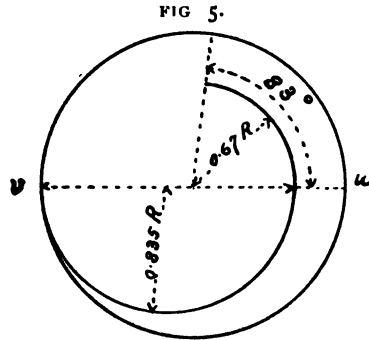

for the inner terminal in the latter always, and most of the time for the outer one. It is one which every workman can draw, and is easy to make. This curve is particularly well adapted for the outer curve of a flat spring in watches, as it is composed of sections of two circles, the outer or end portion of which is concentric to the center of the balance, and therefore lies in the path of the regulator pins. For this curve we are indebted to M. Lossier, in "Etude sur la Théorie du Réglage."

From the center of the spring Fig. 5, and with a radius of 0.67 times the radius of the spring trace an arc of a circle of 83° , commencing at the point where the regulator pins come. From that point to where it joins the

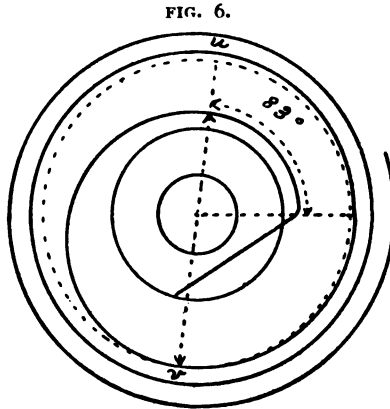

outer circle it is a semi-circle, drawn with a radius equal to

$$\frac{1.67 R}{2} = 0.835 R.$$

R being equal to the radius of the spring. Fig. 6 is the same curve applied to the inner terminal of a flat spring. To make room for this a sufficient number of coils, about four, have to be cut out, and the end bent in to form the curve according to instructions hereafter given.

8. Correction of Terminal Curves.—There can be no doubt that the application of theoretical terminals to the balance spring is a great improvement. The discovery of them has lifted the art of fine watchmaking from the domain of experiment to that of science. They enable us to realize, at last, the isochronism of the spring—for a century or two the dream of watchmakers. Without them nothing else will. Nevertheless, I venture to say that 99 out of 100 chronometers in use will be found to have non-theoretical terminals. Most makers retain the old-fashioned terminals because they enable them, by the manipulation of them, to obtain what they consider close enough isochronism. The fact that we can correct to some extent the anisochronism resulting from disturbing factors, such as the effect of the centrifugal force in the balances, by non-theoretical terminals, is chiefly of value in the case of ship chronometers, in which this disturbing factor, together with the effect of the inertia of the spring, causes a gain in the short arcs of from twelve to twenty seconds in twenty-four hours, as between arcs of 270° and 500°. As these instruments are running in horizontal position only, an eccentric motion of the spring—which non-theoretical terminals always produce—is not so objectionable a feature. What is of greater consequence, however, is the fact that non-theoretical terminals always produce characteristically the same variation of rate, as between long and short arcs, that we have found in springs without terminal curves, both flat and cylindrical (Plates I. and III.)—*i. e.*, the rates when plotted, or coordinated to right angular axes, present the form of some curve, more or less variable,

and that, therefore, they can never properly correct variations due to centrifugal force. A case in point, among others, is a ship chronometer, which came to me in the course of business. The balance spring, a cylindrical one, had the ordinary circular terminals pinned at the angular distance of N coils $+ 270^\circ$, but which the owner claimed to be isochronal, according to his method of testing springs, which was that of obtaining the chronometer's rate with the mainspring fully wound and the chain running on the largest diameter of the fusee, and comparing it with the rate obtained when the spring is let down two or more turns, and the chain is running on the smallest diameter of the fusee. By this method, as will be seen, a comparison is made between two arcs of motion only, supposing the latter to have been constant during each test. I had the curiosity to test it by my method, using weights for motive power instead of the spring, and found that the rate when plotted to right angular axes gave the curve of Fig. 7, down trends indicating retardation, and up trends acceleration of the rate.

It may be seen from this that if the long arcs in his test ranged in the neighborhood of 500° and the short ones at about 300° , which probably was the case, it was possible that it should show isochronism between the two arcs, but that for arcs of motion between these and above and below them, it was very far from being isochronal. To illustrate the effect of centrifugal force alone

FIG. 7.

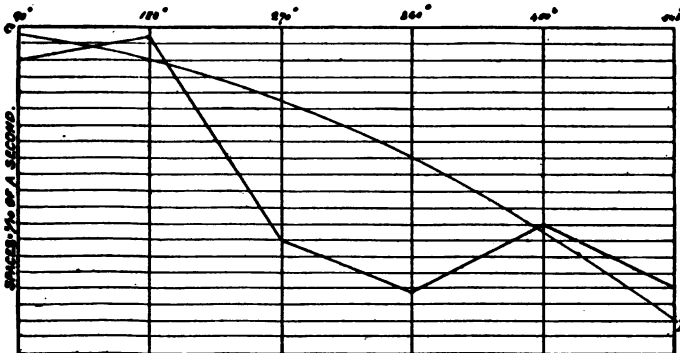

I have added curve C F in Fig. 7, showing by comparison that, except for the middle arcs, the rate of the chronometer was evidently still governed by it.

Non-theoretical terminals, of whatever description, invariably produce variations of this kind, because they produce eccentric motion of the spring, which is equivalent in effect to the eccentric motion of flat springs without terminal curves, the result of which is detrimental to the isochronism of the spring, and for that reason cylindrical springs without correct terminals are clearly little better, if any, than flat springs. I have suggested a better way (6), by retaining the correct terminals and seeking to offset the effect of centrifugal force by suitably choosing the total length or thickness of the spring, so as to produce anisochronism in the reverse direction. The writer ventures the opinion that small daily variations in the rate of chronometers, as well as the phenomenon called "acceleration," neither of which have ever been satisfactorily explained, are due, in great part, to anisochronism of the springs, on account of non-theoretical terminals.

In cases, however, where for one reason or another the length of the spring cannot be changed, the only alternative open to us is the deformation of the curves in order to produce the required result. For this purpose, bearing in mind that it is the effect of the eccentric motion of the spring we wish to take advantage of, we have only to consult Plate I. to find out in which direction to throw the motion, for the effect of eccentric motion is precisely the same in a cylindrical and a flat spring. Assuming that it is the acceleration of the short arcs, due mainly to centrifugal force, we wish to correct, we require an eccentric motion such as will make the short arcs go slower. This we have in the terminal pinning of N coils $+ 180^\circ$, or the pinning at which the two ends of the spring are at opposite sides of the center. In a flat spring the eccentric motion of the spring is always in the direction opposite to the stud; in this case, therefore, it is towards that side on which the inner end of the spring lies when the balance is at rest. This is the determining feature and our guide. Just in proportion as the eccentric motion of the spring is more or less in the direction in which the inner end lies when it is at rest

will the short arcs go faster or slower than the long ones. In the case of the terminal pinning at N coils, or with an even number of coils where the two ends of the spring are pinned on the same side of the center, and the eccentric motion of the spring is therefore in the opposite direction, with respect to the position of the inner end, the short arcs go faster relatively than at any other terminal pinning. These two cases of opposite results are a sure guide for the deformation of the outer terminal of a flat spring, so called "Bréguet," if it were desired to cause the short arcs to go slower or faster, as might be required; but as a guide for the deformation of the cylindrical springs it is not sufficient, for, in the latter, both terminals have to be appropriately altered if the desired result is to be attained.

Returning to the flat spring we must bear in mind that the eccentric motion in the direction opposite the stud is not all the eccentric motion it has. That is the motion due to the non-theoretical form of the outer terminal. There is an eccentric motion due to the non-theoretical form of the inner terminal, the relation of which to that of the outer one must be considered. Now, the eccentric motion of a flat spring whose terminal is a spiral, lying in the same horizontal plane of the rest of the spring, is always in the direction opposite to the pinning point. That is visibly the case with respect to the outer terminal, and it is the case also with respect to the inner one, although not so plainly seen. Reconsidering, with this fact in view, the eccentric motion of the spring, and taking first that of the terminal pinning of N coils $+ 180^\circ$, we see that, while the effect of the outer terminal is an eccentricity of motion in one direction—namely, toward the side on which the inner terminal lies when the spring is at rest, that due to the inner terminal varies in direction as the balance turns around during its motion. When the balance has made half a turn, or an arc of 180° , the eccentricity of the spring due to the inner terminal stands in the same direction with that due to the outer one. After it has made a full turn the eccentricity due to the inner terminal stands in the direction opposite to that due to the outer one. The first represents a full motion of the balance of 360° , during which arcs the rate is slow, and the second of twice that arc of motion, or

720°, during which, or at least up to arcs of 540°, the rate is gaining.

The above analysis establishes the following principle: *Up to the time when the eccentricity of the spring due to inner and outer terminals together tends in the same direction there is a loss; after that, when it tends separately in opposite direction there is a gain in the rate.*

The exact opposite as to the relative eccentric motion due to the inner terminal takes place under the terminal pinning of N coils, the opposite of that of N coils + 180°, which the reader may study at leisure, and therefore we have the exact opposite result in the rate also, as between long and short arcs.

The relative direction of the eccentricity of the spring due to inner and outer terminals separately during the motion of the balance is, of course, continually changing and therefore considerably more complicated; but for our present purpose the analysis we have made of it will suffice.

Inquiring now as to how the deformation of the terminal curves is to be made in order to obtain the particular eccentric motion desired, I observe first, that in order to avoid eccentric motion in the spring, we have seen (7 Fig. 5) that we have to bring in a portion of the outer terminal towards the center and form it into a curve such that its center of gravity shall be at a given distance from the center of the spring. If the distance of its center of gravity from the center of the spring is greater than the given distance there will still be eccen-

FIG. 8.

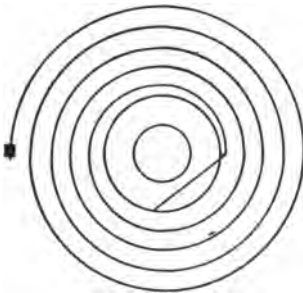
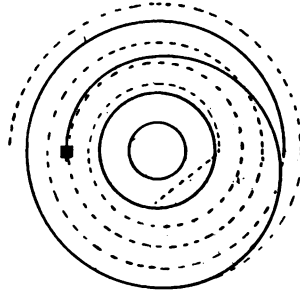

FIG. 9.



tric motion of the spring in the direction opposite the

stud; if less, its eccentric motion would be more in the reverse direction, namely, toward the stud. Let us take two extremes and compare them with a correct terminal, Figs. 8, 9 and 10. In Fig. 8 the center of gravity of the outer terminal is farthest from the center of the spring, the terminal being the original spiral and therefore the eccentric motion of the spring is towards the side opposite to the stud. In Fig. 10 the terminal is practically a straight line passing nearly through the center of the spring and its center of gravity may be assumed to coincide with it. It is evident that the eccentric motion produced by this terminal would all be in the direction of the stud; in fact, the effect is the same as if the stud had been transposed to the opposite side of the spring. Fig. 9 represents a correct terminal.

Now the difference in Figs. 8 and 10 as compared with Fig. 9 is that in Fig. 8 all of the terminal is removed from the center and taken into the main body of the spring, while in Fig. 10 the first half of the terminal has been flattened and brought nearer the center and the portion beyond the diametral line passing through the stud has been removed from the center and taken up into the main body of the spring. I use these ex-

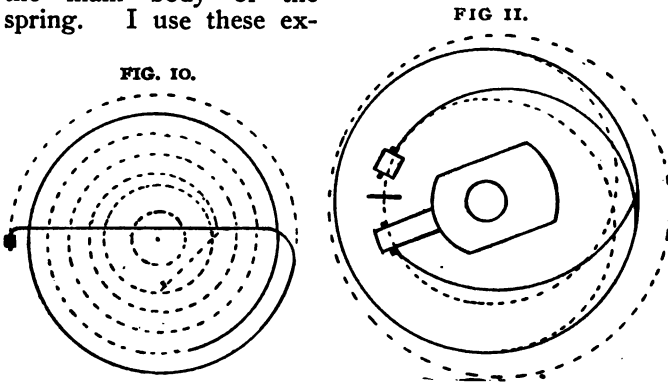

treme cases in order to make plain the instruction intended to be conveyed; the changes necessary to produce the desired effect are as a rule comparatively slight.

The above illustration furnishes the following rule:

1. *To cause an eccentric motion of the spring in the direction opposite the stud, take up some of the terminal into the main body of the spring and thus remove the center of gravity of the curve from the center of the spring, and*
2. *To cause an eccentric motion of the spring in the direction towards the stud, bring the first half of the terminal nearer to the center of the spring, diminishing the distance of its center of gravity from the center, and take up some of the portion beyond the line passing through the center and the stud into the main body of the spring, or remove that portion further from the center.*

The first of these rules applies to the deformation of the upper curve in a cylindrical spring, that which is pinned to the stud, as well as to the outer terminal of the flat spring; the second to that of the lower one, pinned to the collet, for this latter represents the inner terminal of a flat spring. Such a deformation will produce an eccentric motion of the spring exactly analogous to that of a flat spring without terminal curves pinned at the angular distance of N coils $+ 180^\circ$ and will produce a loss in the short arcs of from 10 to 15 seconds in 24 hours as between arcs of motion of the balance of 315° and 500° .

It may be understood that if it were desired to produce an acceleration of the short arcs the exact reverse of the above rule would have to be observed.

The deformation above described will produce a smooth easy motion of the spring. The latter will remain nearly cylindrical for arcs of motion between 320° and 450° and present no unpleasant appearance.

It is exceedingly difficult to explain a matter of so complicated a nature clearly without appearing to be prolix. In order that the reader should be able to reason it out alone it is necessary to go into minutest details at the risk of repetition. My object being to throw light on a problem perplexing to many, this will be excused, particularly if I have succeeded in making it clear. Perhaps the addition of a practical example may be of interest and help to fix the ideas in the reader's mind.

A ship chronometer came to me for repairs, the balance spring being one of the parts that had suffered from unskilled hands. I dressed it and formed the terminals into correct curves. After it was in good order and be-

ing tested for isochronism, I found a difference in the rate between long and short arcs of 12 seconds in 24 hours, the short arcs gaining that much. In the test for isochronism with this chronometer I did not use weights for motive power, as I did in the experiments, this convenience not being at hand, but followed the customary method, which is that of observing the rate with the mainspring all wound and the chain running on the large part of the fusee for the long arcs, and again with the mainspring let down two and a half turns and the chain running on the small part of the fusee for the short arcs. In this particular chronometer this method produced a difference between the long and short arcs of about 180° , the long arcs ranging in the neighborhood of 500° and the short ones in that of 320° . The trials, however, lasted in each case full 24 hours.

After deforming both upper and lower terminals according to the above rule the rate of the chronometer was as follows:

For the long arcs 14. seconds fast
 " " short " 8. " "

making a difference of 6 seconds slower in the short arcs and showing that I had overdone the correction. A slight alteration in the lower terminal only reduced the difference in the rate to the following:

For the long arcs 3. seconds fast
 " " short " 2.1 " "

leaving a difference of 0.8 seconds slower in the short arcs. At this stage the shape of the terminals was as shown in Fig. 11, the dotted curves representing the original theoretical curves, the terminal pinning, before the deformation, having been directly one above the other, thus showing by comparison with the actual curves in what sense or direction the deformation was made. With the present curves the eccentric motion of the spring is as represented by the broken circle—*i. e.*, in the direction opposite the stud; and the spring remains tolerably cylindrical during its motion. A fact worthy of notice, however, is that when afterwards the mainspring was armed in the usual way and the chronometer was running at normal arcs of motion, about 400° , its rate was six seconds fast, showing that, though under the extremes of arcs tested the rate was nearly the same, in

the middle arcs it was gaining, corroborating the statement I made heretofore—that, though we may obtain close enough isochronism between two given arcs of motion with non-theoretical terminals, yet for arcs between these and above and below them they give an entirely different result.

If in ship chronometers we are obliged to resort to non-theoretical terminals, in order to obtain approximate isochronism, such, fortunately, is not a necessity in watches, at least not with the lever escapement. As before stated (3, a), the effect of centrifugal force on the balance of watches is much less than in ship chronometers. Moreover, in the lever escapement, the effect of the unlocking and the impulse (4, c) counteracts the effect of centrifugal force; and if we should find that the short arcs still go a little faster with theoretical terminals, that is not so bad a feature, as we shall see. Besides, we always have a ready means of correcting it, by the manipulation of the regulator pins (4, d). In watches, on the other hand, the problem is complicated by the necessity of position adjustment, and it is with respect to this branch of the work that theoretical terminals are of most valuable service; for, however slight the eccentric motion of the spring may be, it always produces considerably greater position error. The most perfect theoretical curves for both inner and outer terminals of a flat spring are not too good; nay, even these, as we shall hereafter show, will not wholly remove the eccentric motion of the spring, or its effect: position error.

CHAPTER II.

ADJUSTMENT TO POSITIONS.

9. Position Error.—Position adjustment relates to and is important only in the adjustment of watches, owing to their being what is termed portable timepieces.

In discussing this subject it is assumed that a watch is in good order, that the mechanical functions of its train and escapement are perfect, or as near so as can be made; that from barrel to balance its condition is irreproachable, and particularly that of the last-named organ. Errors of position in the rate of watches may indeed, and frequently do, arise from mechanical imperfections, particularly from imperfections in the escapement, the balance pivots and the jewelings; but with these the present chapter does not deal, that being reserved for Chapter IV., 17. What it does deal with is solely a function of the balance spring as governed by the motion of the balance and the force of gravity, and its effect on the rate of the watch in vertical positions.

That this function and its effect are generally ignored is evident from the claims put forth by manufacturers, of watches being adjusted to positions, etc., in which not the slightest sign is visible that the principles upon which position adjustment rests are understood or even suspected; and that these claims go unchallenged is proof that the great mass of watchmakers are not only ignorant of position adjustment, but are lacking experience as to how these so-claimed adjusted watches really perform.

As a matter of fact, a mechanically perfect watch—one

which can be said to be irreproachable in its construction from barrel to balance—will vary in its rate all the way from 15 to 30 seconds in 24 hours, between some two vertical positions, as the effect of the motion of the balance spring alone. In watches less perfect this error frequently amounts to 40 and 60 seconds in 24 hours. I have the records of watches that were claimed to be “fully adjusted” by the makers, whose position error exceeds even the latter quantity. To correct this difference in rate, or at least reduce it to its lowest term, is the object of position adjustment.

10. Proper Motion of the Balance Spring.

Probably few watchmakers have any conception of the real or proper motion of the spring during the vibrations of the balance. By “proper motion” I mean the motion peculiar to a spiral spring, as well as to a cylindrical one, when attached at one end to the balance in motion, and at the other to the frame of the watch; a motion distinctly different from the eccentric motion dealt with in the previous chapter. Prior to the time when I made my experiments, from 1879 to 1885, nothing had ever been published on the subject; even now the matter is only superficially dealt with in the best treatises extant. I refer to the work by M. Lossier, quoted before.

In searching for the cause of position error in watches which I had especially prepared with a view to making them as near mechanically perfect as possible, as the almost unlimited means and time at my disposal enabled me to do, I was led to study this function of the spring particularly, being in a manner forced to conclude, from experience, that position error is, in some way, wholly due to the action of the spring. If we examine a flat spring in action we see at once that it has a radial motion—*i. e.*, during the motion of the balance it moves to and from the center. On closer inspection we discover also a circular motion—*i. e.*, a turning of its coils with the balance around the latter's center. On reflection, this is an obvious necessity, since the inner end is attached to the collet revolving with the balance around its center. But all the coils of the spring cannot move equally in both circular and radial lines, since the outer end of it is attached to

the stud, a fixed point in the frame of the watch. Starting, for instance, at the stud, where the spring has neither circular nor radial motion, and moving along the first coil inward, we soon observe a radial motion; on arriving at the beginning of the second coil we perceive also a circular one. This circular motion of the coils increases as we follow them inwardly toward the center, and the radial motion, at maximum in the outermost coil, diminishes until we reach the inner end of the spring, where it vanishes, and the circular motion becomes maximum. So far this motion of the spring is obvious on reflection; but from the combined circular and radial motion there is

FIG. 12.

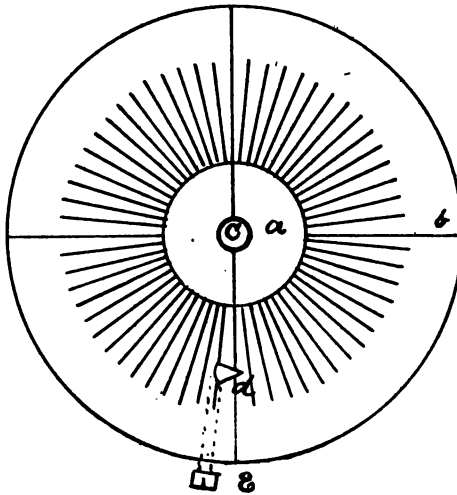

a resultant motion, which is not so obvious, and which it is difficult clearly to comprehend by reasoning alone. An idea occurred to me by means of which I was enabled to make this motion visible to the eye and to study it at leisure. I constructed a little platform, illustrated enlarged, in Fig. 12, formed of two discs, a and b, the inner one being fitted to the arbor c, and the outer one turning on it by loose friction, the two being mounted, by the central arbor, on a pedestal of wood. On this platform I placed a colleted balance spring, the collet going on the arbor c, and the stud into the hole d, made for

that purpose in the outer disc, and fastened by a screw e. By holding still the outer disc and turning the inner one, I could subject the spring to any circular movement I desired to study it in; the phenomenon presented was exactly that which takes place in the spring under the motion of the balance. Moreover, by touching each coil with a trifle of white paint, so as to leave a mark on each, all in a radial line, the displacement of these marks through the motion of the disc revealed to

FIG. 13

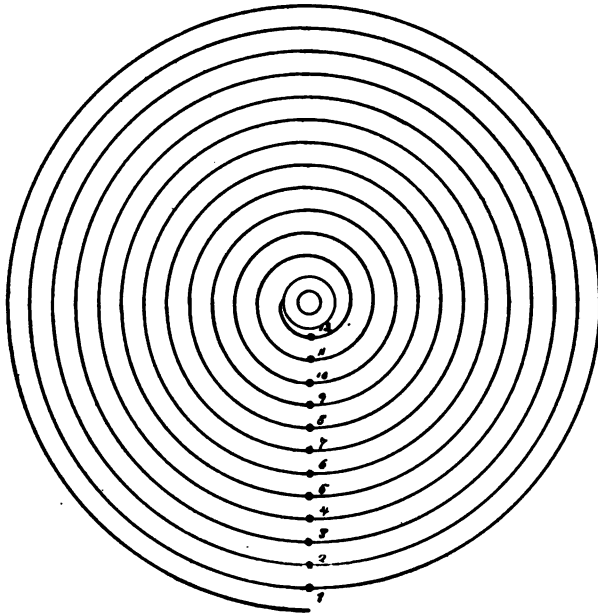

me not only the exact amount of angular motion of each for a given arc of motion of the disc, but the path which each described during its displacement. The radial divisions on the outer disc enabled me to measure the angular motion of the marks, and therefore the relative motion for a given arc of each of the coils. This stated, let us pass to the consideration of Figs. 13, 14 and 15, representing a flat spring on a large scale under examination. In Fig. 13 the spring is represented as being at

rest—*i. e.*, under no tension, and the points [or marks] 1, 2, 3, 4, etc., to 12) are all in radial line. In Fig. 14 we have it as it will appear when the balance has been turned around half a turn, or 180° , in the direction in which the spring would contract upon its center, the stud remaining at the same place. From what has been said above, it is evident that in this state of the spring the marks on the different coils must now occupy relatively different positions, both as to radial distance and angular location. In fact, while mark 12 on the innermost coil has moved around the center just 180° , having all the circular mo-

FIG. 11.

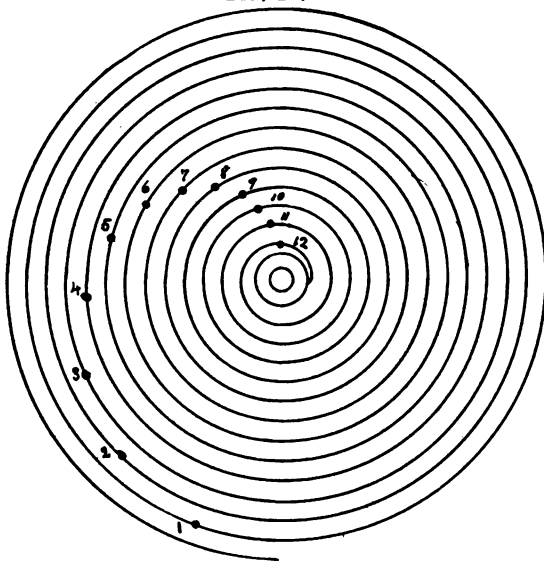

tion the balance has, on account of its proximity to the collet, and little or none in a radial direction, the next mark, 11, must lag a little behind, the next still more, and so on to mark 1, which has moved but a trifle from its initial position, when the spring was under no tension. At the same time, all the marks have moved a little nearer the center by reason of the contraction of the spring; the outer ones more and the inner ones less. In Fig. 14, therefore, the relative positions of the points marked illustrate the "proper motion" of the spring for

an arc of 180° under the contraction of the spring. On turning back the disc to its initial position, all the marks resume the radial position, as in Fig. 13, and turning it from this point 180° in the reverse direction, that in which the spring unwinds and expands, we obtain the relative positions of the marked points shown in Fig. 15, similar

FIG. 15

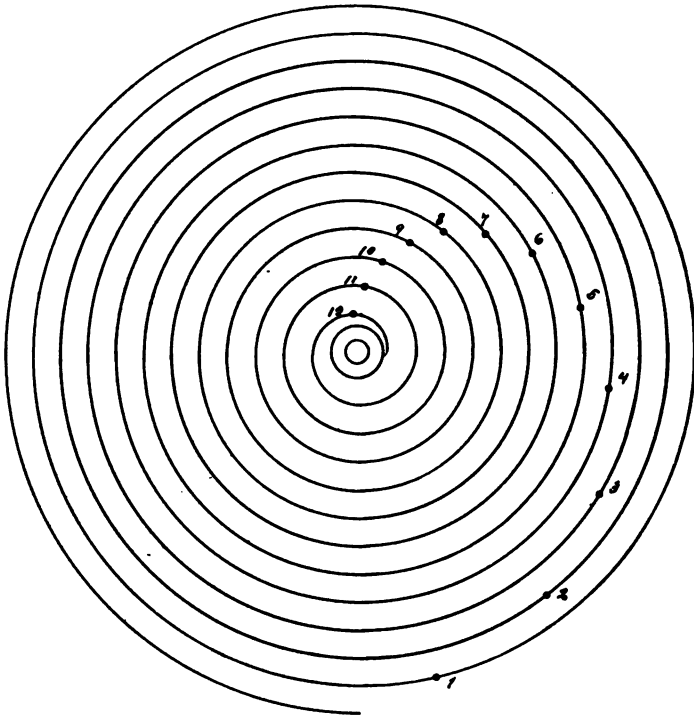

to their position in Fig. 14, only now on the reverse side of the center and all of them a little farther away from it, by reason of the unwinding of the spring. In this case, therefore, we have an illustration of the proper motion of the spring under an arc of motion of the balance of 180° in the direction in which the spring expands. In putting the two together, therefore, and tracing the path which each of the marks has described in passing from

the position, as represented in Fig. 14, to that in Fig. 15, we find that that path is, for all of the points, a more or less elliptical curve, whose radius is constantly changing—*i. e.*, if instead of spirals we imagine circles drawn in Fig. 13 from the center through the marks on the coils, in Fig. 14, these points will all fall inside, and in Fig. 15 outside, of these circles, showing that the coils are constantly moving from a point nearer the center on one side to a point farther from the center on the other, the extent of their motion varying with the arcs of motion of the balance.

It may be claimed that this elliptical motion of the spring takes place in every part of it, all around the center, and that the effect of it as to position error is thus neutralized; but I have abundant evidence for stating that such is not the case, as will presently be shown. A little reflection, moreover, will make it obvious that there must be a difference in the extent of this motion in different parts of the spring, since one end of it is fixed in the frame of the watch, and is therefore stationary, while the other end moves with the balance around its center. And this is the case whether the spring be a plain flat one or one with outside terminal curve. The effect of this motion will be found to manifest itself in position error in different positions of the watch, according to the extent of the motion of the balance.

There is a slight inaccuracy in the Figs. 14 and 15 as illustrating the motion of an ordinary flat spring, inasmuch as the stud is there supposed to be moved to and from the center, which is not the case in the actual problem; but this is of no importance. Besides, the figures illustrate exactly the case of a flat spring with correct outer terminal, and thus incidentally prove that the latter does not correct the error arising from this factor, which, everything else in the watch being faultless, is the sole remaining cause of position error.

It may surprise some watchmakers to see it stated that precisely the same position error arising from the same cause exists in the cylindrical spring; yet such is the case, and for good reasons in a more marked degree than in the flat spring. We have been led to believe that a cylindrical spring is superior to a flat one for the reason that all its coils are circles equidistant from and

concentric to the balance arbor and that, therefore, its center of gravity coincides with the latter. This is true enough as long as it is in a state of rest; but the moment

FIG. 16.

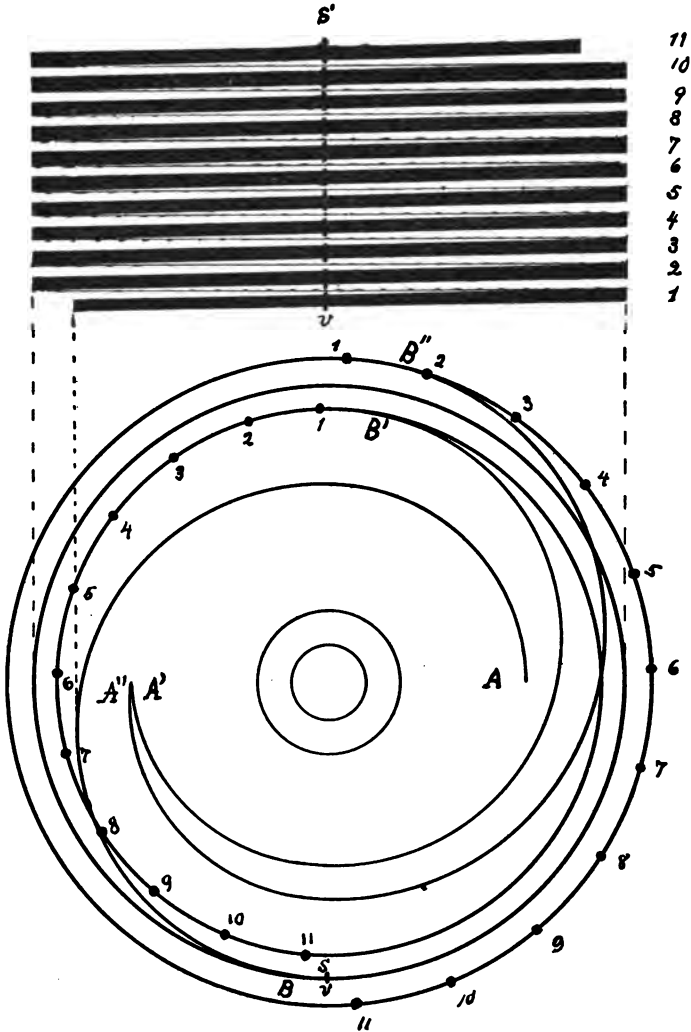

it is set in motion, under the influence of the balance, its static equilibrium is disturbed and another state of things is brought about which is the result, solely, of the "proper motion" of the spring, producing what may be called the oscillation of its center of giration.* Let us study this motion with the help of Fig. 16, representing a cylindrical spring in ground plan and elevation. As in the flat spring, so in this, one end of it is fastened to the stud, a fixed point in the frame of the watch, while the other, fastened to the collet, moves freely with the balance. Between these two points the circular motion varies from nothing to the full arc which the balance describes. If we further examine the movement of the spring, section by section, during the expansion and contraction it undergoes, we find that each section moves in a path of its own. In the ground plan of the figure the curve A B and the circle which it joins represent the position of the lower terminals, and the cylindrical portion of the spring when at rest, A being the point at which it is fastened to the collet. A' B' and A'' B'', respectively, and the circles which they join, represent the position of the same terminal and cylindrical portion of the spring after the balance has moved through an arc of 180° to either side from the state of rest, A' B' and its adjoining circle being the position they occupy with respect to the center when the movement of the balance is in the direction of winding up the spring and the cylindrical portion contracts, and A'' B'' and its adjoining circle that when the balance has moved back again past the state of rest and 180° in the reverse direction. The two latter positions, therefore, represent the movement of the spring during an arc of 360° of the motion of the balance. The upper terminal, which is fastened in the stud, is not represented in the plan, as it is not necessary for our demonstration. Suppose that, before any motion was communicated to the balance and while the spring was in a state of rest, we have marked each of the coils composing the cylindrical portion of the spring in vertical order, as shown in the elevation by the marks s' v and numbered in the margin I to II, number I being the mark on the lowest coil at the point where the lower terminal joins the cylindrical portion, then will those marks severally occupy the places indicated by the numbers in the ground plan, after the bal-

ance has been moved as above described. Point 1 will have moved through an arc of nearly 360° , while every succeeding point has remained a little behind until point 11, which is on the topmost coil near the end, fastened in the stud, has scarcely moved at all in circular arc. Furthermore, all the points have moved in radial sense a distance equal to the extent of the expansion and contraction of the cylinder forming the main body of the spring. By reason of the theoretical terminals this latter motion is the same in all of them; but the path which each of the points marked has described is a resultant of their circular and radial motion, and, by reason of the form of the spring, is a spiral differing in degree for each of the points. It will be easy for the reader to trace this path mentally for each, by connecting those numbered alike in inner and outer circle by a curve passing through point s v in the ground plan, and it will be seen that there is here a "proper" motion of the body of the spring, similar to that in the flat spring, and this in spite of theoretical terminals. Nor is it difficult to predict what portion of the spring will exert the most influence on the rate of the watch in vertical positions under the arc of motion here assumed, for it will be that portion in which the greatest momentum is centered, which is plainly that whose path of motion is the longest, since all of the points travel their several paths in one and the same time (13). It is, however, plain also, as it is in the case of the flat spring, that the position error due to this motion must vary with the arcs; and that beyond a certain arc of motion of the balance it may be the reverse in character. We shall see this demonstrated presently by practical examples.

It will be observed that the illustration I used in the above reasoning supposes a spring with theoretical terminals. It, therefore, shows that the latter do not obviate position error, although they reduce it. The same is true of the flat spring with theoretical terminals. That portion of a flat spring which lies between the inner and outer terminal curve, however perfect the latter may be, being a spiral, will always move and affect the rate of the watch as I have described.

I have intimated heretofore that the position error in a flat spring is generally relatively smaller than in a

cylindrical one. This is a fact, not only of common experience but readily demonstrated. In a cylindrical spring where all the coils are equidistant from the center, the disturbing factor arising from the oscillation of its center of giration—for that is what really takes place—acts upon a longer lever, relatively, than in a flat spring. No superiority can be claimed, therefore, for the former; and I know of no spring, whatever may be its form, that is free from the defects here treated.

11. Experimental Demonstration.

a. The Flat Spring. The discovery of the cause of position error in watches would be of little practical value to us if we could not determine it specifically under known conditions, particularly if we could not orient it beforehand with respect to the figures of the dial. Considering the complex form of the balance spring, particularly that of the flat one, this seems well nigh an impossible task. Indeed, the ablest mathematical analysis to date has failed to completely solve the problem. In our endeavor to apply the results of mathematical investigation we are frequently disappointed, and are ultimately obliged to resort to the experimental method, the only method, after all, in my opinion, which will yield the necessary practical information. But it is not enough to observe simply the general phenomena of the variation of the rate in different positions; we must observe it under known conditions. It seemed to me important to know, first of all, in what relation to terminal pinning of the spring position error manifests itself. In this behalf, it was necessary to observe several precautionary measures. It is evident, in the first place, from the foregoing analysis of the "proper motion" of the spring that the effect of the oscillation of the center of giration resulting therefrom would vary with the arcs of motion; in fact, as we shall see, it is exactly the opposite in characteristic between long and short arcs. Furthermore, it was necessary to guard against the effect of anisochronism of the spring. To this must be added another possible source of interference, and that is a defect in the poise of the balance used, which, in spite of the closest attention in that respect, might escape our vigilance.

One condition occurred to me which would insure my

results against all three of these contingencies, and that is, to make the experiment by maintaining the arc of motion of the balance constantly at 440° , for it is well known that, for that arc of motion, or nearly that, any amount of defect in the poise of the balance cannot affect the

TABLE 4.

Showing variation of rate with a flat spring for eight different terminal pinnings and for all the vertical positions of the dial up, under arcs of motion of 440° . Quantities represent reductions to 24 hours. The stud was situated at the Figure V of the dial.

N. B.—The sign + indicates that the rate is losing, and the sign — that it is gaining.

Figs.	17	18	19	20	21	22	23	24
Position up.	N Coils.	N Coils + 45°	N Coils + 90°	N Coils + 135°	N Coils + 180°	N Coils + 225°	N Coils + 270°	N Coils + 315°
	Secs.	Secs.	Secs.	Secs.	Secs.	Secs.	Secs.	Secs.
I	+ 4.8	+7.7	+3.6	-0.9	-8.4	- 3.1	-2.4	+3.6
II	+10.9	+4.	+1.5	-3.3	-3.6	- 2.4	$\pm 0.$	+4.8
III	+ 7.	+1 7	-1.2	-6.9	-4.8	- 0.7	+2.4	+7.2
IV	+ 1.2	-1.9	-3.6	-3.3	-1.2	+ 2.9	+6.	+7.2
V	- 2.	-4.3	-9.6	-4.5	+1.2	+ 4.1	+8.4	+3.6
VI	- 2.4	-6.7	-3.6	-3.3	+4.8	+ 6.5	+6.	$\pm 0.$
VII	- 3.6	-2.5	$\pm 0.$	+2.7	+8.4	+ 8.4	+2.4	-1.2
VIII	- 8.4	-0.1	+1.	+5.5	+7.2	+ 4.1	$\pm 0.$	-2.4
IX	- 7.6	$\pm 0.$	$\pm 0.$	+7.	+2.4	- 0.7	-4.8	-6.
X	- 3.6	+0.7	+1.2	+7.5	+1.2	- 3.1	-8.4	-7.2
XI	- 1.2	+4.3	+3.	+1.5	-4.8	- 5.5	-4.2	-6.
XII	+ 1.2	+6.4	+4.8	-0.9	-4.8	-10.3	-4.8	-2.4

rate of a watch in vertical positions, while the maintaining constantly of the same arc of motion would, of course, insure the result against anisochronism of the

spring. All other things remaining the same, the resultant variation of rate in positions would be due, in the main and characteristically at least, to the oscillation of the center of giration of the spring resulting from the "proper motion" discussed above.

I have already described (Chap. I, 5) the method I employed in making my experiments, as well as the precautions I took to secure reliable results. Suffice it to

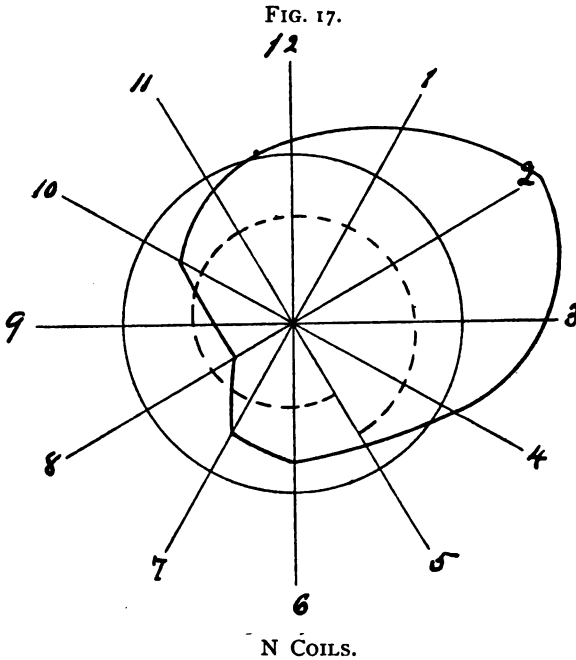

say here that in the experiments reported below the same conditions and precautions were observed.

A balance spring being properly prepared and adapted to the balance, I observed its rate in all the twelve positions of the dial up under arcs of 440° ; first, with an even number of whole coils—*i. e.*, when the angular distance of terminal pinning was 0; then with an angular distance of 45° , and again with it at 90° , and so on for every 45° difference in the angular distance of the termi-

nal pinning, in one and the same coil, until the whole coil was used up, and the angular distance of the terminal pinning became 0 again, taking the spring up on the outside by an eighth of a coil at a time, the stud, meanwhile, occupying the same position with respect to the figures of the dial—namely, at the figure 5, so that the relative position of the inner pinning alone changed by altering the angular distance of the terminal pinning. Table 4 contains the result of this experiment. The

FIG. 18.

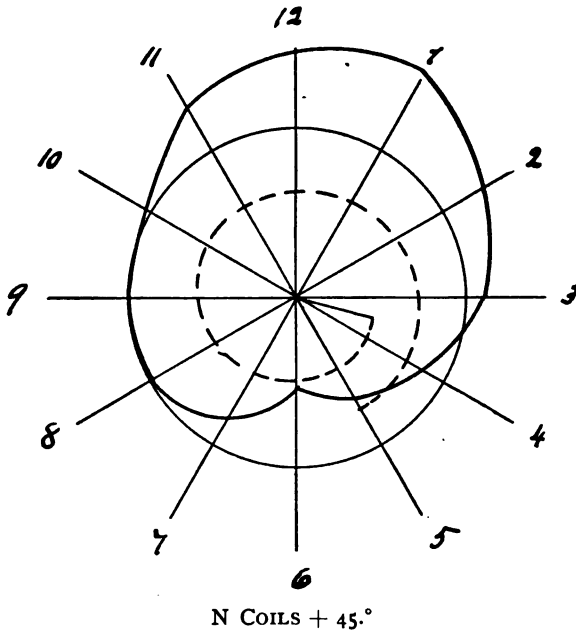

quantities are the reductions to the mean rate of the respective terminal pinning and to an interval of twenty-four hours. The first left-hand column gives the figures of the dial up; the top horizontal one, the angular distance of the terminal pinnings, the capital letter N mean-

ing some number of whole coils. The vertical columns of figures under the respective terminal pinnings are the corrections to the mean rate, obtained with the terminal pinning heading them, and under that figure of the dial up which is opposite them in the left-hand

FIG. 19.

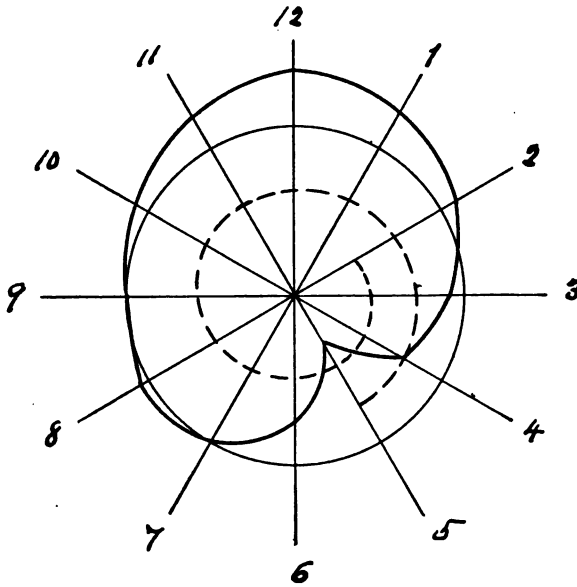

N COILS + 90°

column. The sign + prefixed to the quantities must be taken as indicating that the rate was slow by the quantity before which it stands, and the sign — that it was fast. The most superficial inspection of the table will reveal the fact that the rate varies greatly under the different figures of the dial up, as well as for the different terminal pinnings under the same figure. Indeed, not only does it differ quantitatively, but the signs prefixed change from one to the other, both as we pass along the

horizontal lines of figures or follow the columns vertically; and it is plainly apparent that the variations depend on and are governed by the changes made in the terminal pinnings.

To assist the understanding, and make the result of this experiment visible at a glance, I have illustrated Table 4 in Figs. 17 to 24, inclusive, by co-ordinating the

FIG. 20.

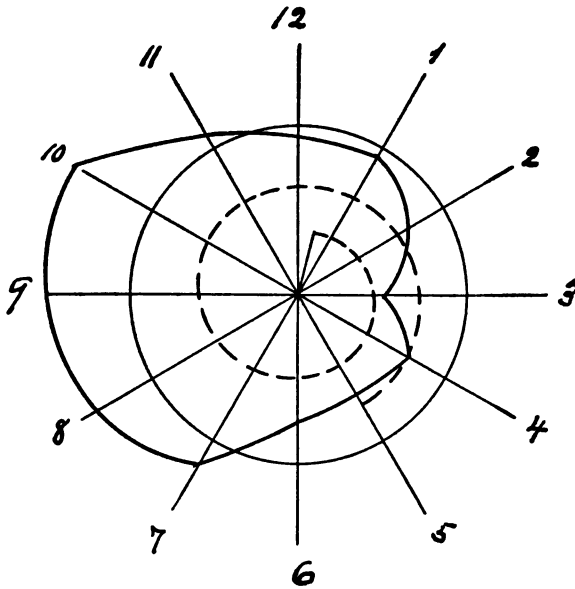

N COILS + 135.°

quantities under each separate terminal pinning to circles, the radial lines or ordinates representing the figures of the dial. Each of the figures illustrates the result of the terminal pinning in the respective column numbered as the figure, over the top of the table, quantities prefixed by the + sign being plotted outside of the circle, and those prefixed by the — sign inside, the

connecting of the points thus plotted forming the elliptical figures, shown by the black curves. In addition to this the relative position of the terminal pinnings is shown by the broken spiral, the outer end commencing in all the figures at the figure 5 of the dial. These figures illustrate the fact, more plainly than can be seen

FIG. 21.

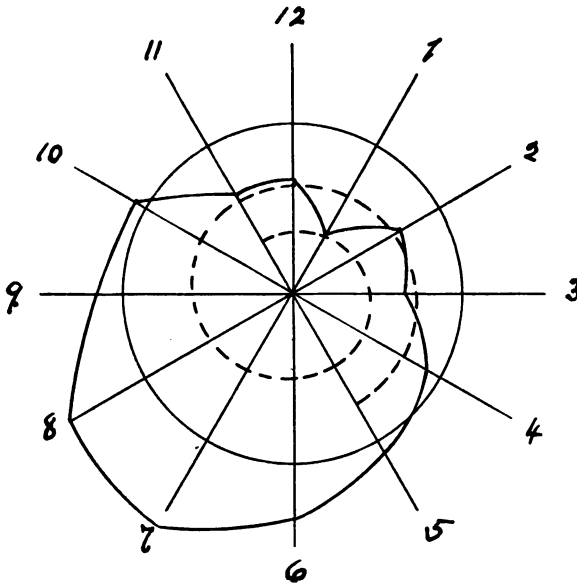

N COILS + 180.°

in the table, what I have stated before, that the location of the variations of rate, relative to the figures of the dial, changes with and follows the changes in terminal pinning. The rates thus plotted produce more or less elliptical figures, the major axis of which passes through the center and through the middle of the first half of the innermost coil of the spring, about 90° from the inner pinning point, while their minor axis, nearly at

right angles to the major axis, passes through the inner pinning point, and also very nearly through the points in the circle where the elliptical curves bisect the latter. Thus, while the major axes locate the positions of greatest variation in the rates, the minor axes locate the position of least variation with reference to the terminal pinnings of the spring; and as we pass in our inspection

FIG. 22.

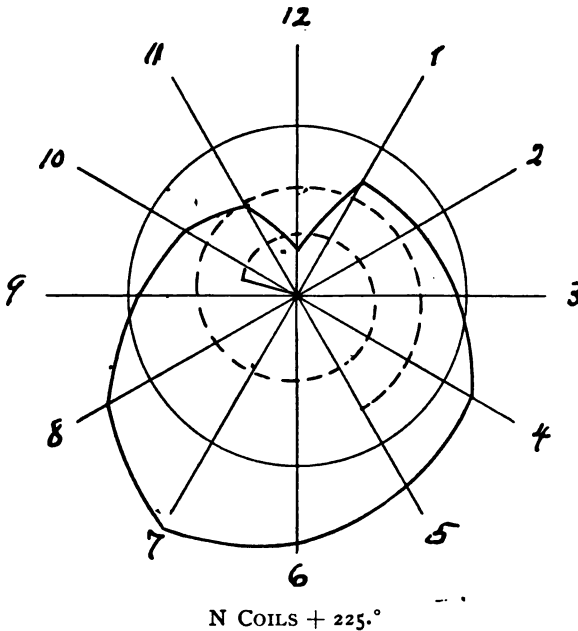

from one figure to the other, through the whole of the eight experiments, we see how the elliptical figures wheel around the center, exactly following the changes in the terminal pinning, or the changes in the relative position which the innermost coil of the spring occupies with respect to the figures of the dial, the fastest rate always occurring in that position where the middle of the first half of the innermost coil happens to be up, while the

slowest rates occur in just the opposite position. Nothing could be more conclusive proof, first, that *position error is due to the oscillation of the center of giration of the spring*; and, second, that *its localization among the figures of the dial depends upon the angular distance of the terminal pinnings of a spring, the position of the stud being given.*

FIG. 23.

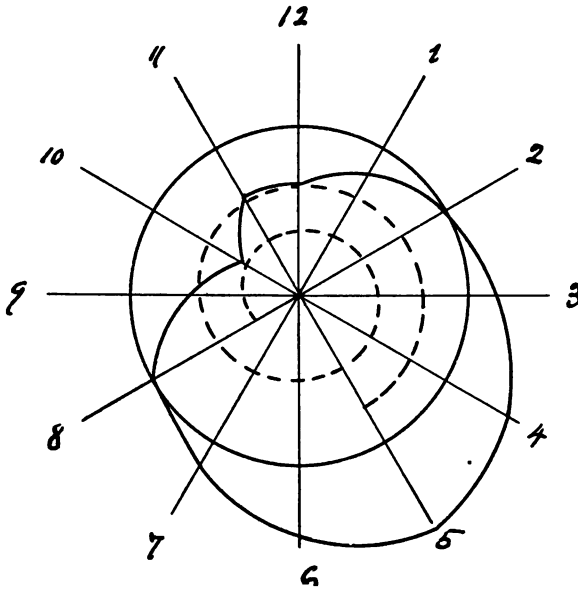

N COILS + 270°

We have in this experiment demonstrated the position error under arcs of motion of the balance of 440°. This proves it to be independent of the poise of the balance. We have, however, also proved that the factor which produces it affects the motion of the balance in the same way as does a want of poise, only under a different arc of motion, under which the latter would have no effect. It remains for us to inquire: What will be

the characteristic of the position error under different arcs of motion? To this purpose I have continued the experiment, observing the rate of the chronometer again in all the twelve positions of the dial, but varying the arcs of motion of the balance in each position—*i. e.*, taking its rate first under arcs of 180° , then under 270° , 360° , 450° and 540° in one and the same position of the dial

FIG. 24.

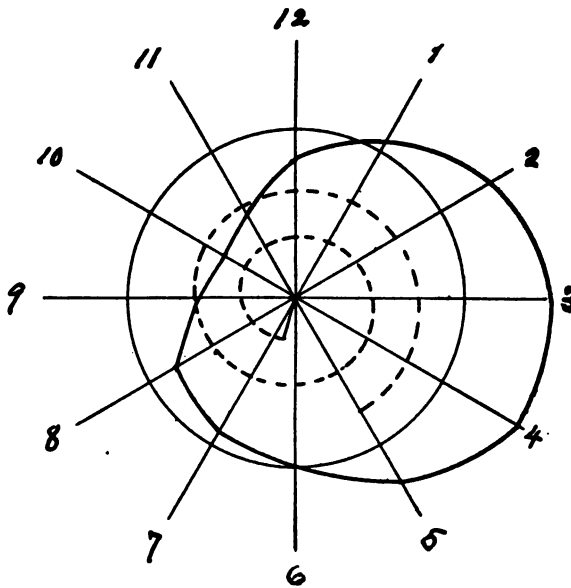

N COILS + 315°

up, until I had a complete record of its rate in all the twelve positions. In order not to needlessly encumber the work, I will select two only of the experiments made with flat springs, from a great many, all of which give testimony to the same characteristic variation.

Tables 5 and 6 contain the results obtained with one and the same flat spring; first, Table 5, without terminal curves; afterward, Table 6, with correct outer terminal

curve. The rates are computed for four hours only, instead of the twenty-four.

I have illustrated Tables 5 and 6 on Plates IV. and V., respectively, in the same way as the previous experiment, using the rates as the co-ordinates of curves and plotting them around a common center. The heavy black circle represents mean time, + quantities being plotted out-

TABLE 5—(see Plate IV.)

Showing rate with a flat spring without theoretical terminals in all the vertical positions of the dial up, and under five different arcs of motion.

N. B.—The sign + indicates that the rate is losing, and the sign — that it is gaining.

Positions up.	180°	270°	360°	450°	540°
	Secs.	Secs.	Secs.	Secs.	Secs.
I	+0.8	+0.3	+0.5	+0.3	+0.3
II	+5.	+2.	+0.6	-0.3	-1.5
III	+6.8	+4.1	+1.	-0.9	-1.7
IV	+8.6	+4.3	+1.1	-1.5	-2.1
V	+7.6	+4.1	+1.3	-0.9	-1.1
VI	+5.2	+2.3	+1.1	-0.7	-0.7
VII	-0.6	+0.2	+0.1	-0.2	+0.2
VIII	-3.6	-2.3	-1.1	+0.9	+0.7
IX	-7.6	-4.3	-2.1	+1.5	+2.1
X	-9.2	-4.9	-1.1	+1.3	+1.8
XI	-8.	-3.6	-0.9	+0.8	+1.3
XII	-4.8	-1.8	-0.5	+0.4	+0.7

side, and — quantities inside the circle, while the radial lines are the ordinates, representing the positions of the dial. The connecting of the plotted rates by the elliptical curves makes visible the characteristic variation of the rate, in positions, for each arc of motion of the balance. The numbers designating the different curves indicate the arc of motion to which they relate. In addition, the broken spiral in the center shows the relative position of the terminals of the spring.

It will be observed, first, that all the curves have one major and minor axes in common, and, second, that the major axis passes through the same point of the balance spring as in the preceding experiment—*i. e.*, through the middle of the first half of the innermost coil, while the minor axis, or an axis at right angles to the major axis passing through the center, passes also through the

TABLE 6—(see Plate V.)

Showing rate with the same spring as in Table 5, under the same conditions, but made into a Breguet with correct outside terminal.

N. B.—The sign + indicates that the rate is losing, and the sign — that it is gaining.

Positions up.	180°	270°	360°	450°	540°
	Secs.	Secs.	Secs.	Secs.	Secs.
I	+ 3.9	+1.9	+0.6	—0.1	—0.3
II	+ 6.5	+3.4	+1.	—0.4	—1.
III	+10.	+4.4	+1.1	—0.7	—1.9
IV	+ 8.7	+4.2	+1.2	—0.8	—1.8
V	+ 4.2	+3.4	+1.1	—1.	—1.3
VI	+ 0.9	+1.7	+0.6	—0.7	—0.4
VII	— 4.1	—1.9	—0.9	+0.3	+0.4
VIII	— 6.5	—4.9	—1.3	+0.9	+1.2
IX	— 9.2	—5.1	—1.8	+0.9	+2.2
X	— 8.3	—4.4	—1.3	+1.	+1.7
XI	— 5.5	—2.6	—0.1	+0.4	+0.9
XII	— 1.3	—0.2	+0.2	+0.2	+0.4

inner pinning point of the spring, and the points in the circle bisected by the elliptical curves, or nearly so. The eccentricity of the elliptical curves shows the relative variations of the rate in positions for the different arcs of motion. The greatest variation occurs under the arc of 180°, the rate in that arc being very slow on one side of the center and very fast on the other, and we see that the character of its variation in this arc, as referred to the relative position of the terminal pinning, is the direct

opposite to what it was for arcs of 440° , as illustrated in figures 17 to 24. The same is the case for arcs of 270° and 360° , but from that on, passing to the higher arcs, the characteristic of the variations is the same—*i. e.*, the rate is fast in the position which coincides with the middle of the first half of the inner coil, and slow on the opposite side of the dial. Plate V., illustrating Table 6, shows the rate obtained with the same spring after it was made into a Bréguet with correct outer terminal. It exhibits no essential difference in the character of its variations, except that the position of the major axis of the elliptic curves is shifted a trifle, relative to the positions of the dial, corresponding to the shifting of the inner pinning point of the spring, by reason of the outside terminal being made into a curve, occupying a position nearer the center. The improvement here, if any, is very slight, showing that a plain, flat spring is nearly as good for position adjustment as one with outside terminal curve only.

b. The Cylindrical Spring.—The following tables, 7, 8, 9 and 10, are compiled from the rates obtained with a cylindrical spring without terminal curves, subjected to the same experiment as related above, under four different angular distances of terminal pinning, the stud remaining at the same place with respect to the positions of the dial. These tables are illustrated graphically in Plates VI., VII., VIII. and IX., respectively which will scarcely require any further explanations than what were given for the preceding Plates IV. and V. above. The reader must now be sufficiently posted to understand them at a glance, and be able to appreciate the general results. They do not differ from the preceding ones in characteristic variations or location of the major or minor axes of the elliptic figures produced by the plotting of the rates. The position in which the greatest variation in rate occurs is determined by the same condition—namely, the position which the middle of the first half of the inner coil (in this case, the lower one, that which is pinned to the stud) occupies with respect to the figure of the dial, and the major axis of the elliptical curves moves around among the figures of the dial with the same changes in terminal pinning, and in the same way as in the result of experiment with the flat spring. The spring

was pinned top and bottom at the same distance from the center, but in the drawing I have shown the location of the point pinned to the collet by deviating the broken circle, representing the spring, for the first quarter of a coil. It will be seen that the transition from slow to fast, and vice versa, of the curves on the major axes of

TABLE 7—(see Plate VI.)

Showing rate with a cylindrical spring without theoretical terminals in all the vertical positions of the dial up, and for five different arcs of motion. Terminal pinning = N. Numbers of coils, the outside, or stud, being at the Figure 5.

N. B.—The sign + indicates that the rate is losing, and the sign — that it is gaining.

Positions up.	180°	270°	360°	450°	540°
	Secs.	Secs.	Secs.	Secs.	Secs.
I	—23.6	—5.	+4.9	+11.1	+7.5
II	—26.4	—9.2	+6.2	+11.7	+9.1
III	—24.8	—8.3	+3.4	+10.6	+8.7
IV	—14.4	—3.5	+2.3	+ 5.8	+4.1
V	— 0.4	—0.3	—1.4	— 2.6	—0.5
VI	+13.2	+5.	—3.8	— 5.5	—0.9
VII	+27.6	+6.	—5.6	—10.8	—4.9
VIII	+29.2	+5.7	—4.8	—11.	—7.6
IX	+19.6	+5.3	—4.6	— 8.8	—8.1
X	+14.8	+4.5	—1.1	— 5.3	—5.
XI	— 1.6	+1.2	+0.7	+ 0.3	—3.1
XII	—15.	—1.5	+4.	+ 4.7	+0.7

the elliptic figures occurs between the arcs of 270° and 360°, whereas in the experiment with the flat spring it occurs between those of 360° and 450°. This is due to the very much greater variation of rate under arcs of 180° in the cylindrical spring, by reason of which the mean rate of all the arcs occurs at a lower arc. Again,

the rate for arcs of 540° , or the elliptic curve representing it, falls back inside of that of the arc 450° —i. e., the greatest eccentricity, in the long arcs, is shown to occur under arcs of 450° , whereas in the flat spring it occurs under arcs of 540° . This shows that the center of gravity in the cylindrical spring under the latter arc had

TABLE 8—(see Plate VII.)

Showing rate with the same cylindrical spring as in Table 7, under the same conditions, but with terminal pinning of N coils + 90° , the stud being at the Figure V of the dial.

N. B.—The sign + indicates that the rate is losing, and the sign — that it is gaining.

Positions up.	180°	270°	360°	450°	540°
	Secs.	Secs.	Secs.	Secs.	Secs.
I	—19.	—8.	+0.5	+ 6.	+5.7
II	— 6.8	—5.8	—3.1	+ 0.6	+1.3
III	+ 5.7	—0.6	—4.3	— 5.8	—2.7
IV	+12.1	+3.2	—6.1	—10.4	—5.9
V	+26.5	+6.6	—5.9	—12.	—9.5
VI	+27.9	+6.6	—3.6	—10.4	—7.5
VII	+15.	+6.6	—0.7	— 6.	—6.9
VIII	+ 6.	+5.2	+2.7	— 1.4	—1.5
IX	— 4.3	+2.	+4.5	+ 5.	+3.5
X	—18.2	—2.	+6.5	+ 8.8	+5.9
XI	—23.1	—6.8	+6.1	+12.	+9.7
XII	—26.1	—7.4	+2.9	+ 9.2	+8.5

a circular motion greater than 440° . It will also be noticed that the variations of the rate in this spring are excessively great, the quantities being the reductions to four hours' time only. This is due to the fact that the spring was purposely made of very large diameter, in order to magnify the effect I desired to study (3, b).

I have only to add Table II, which gives the result of an experiment with the same cylindrical spring after its

terminals were made into theoretical curves. Plate X. illustrates this table, and a glance at it will reveal the fact that the position error is very much reduced by the correct terminals, the rates being computed for the same interval of time, although, as I predicted, by no means removed. I notice, too, that the transition from slow to fast rates on the major axis of the elliptic curves occurs

TABLE 9—(see Plate VIII.)

Showing rate of the same cylindrical spring as in Tables 7 and 8, under the same conditions, but with terminal pinning of N coils + 180° , the stud being at the Figure V of the dial. —

N. B.—The sign + indicates that the rate is losing, and the sign — that it is gaining.

Positions up.	180°	270°	360°	450°	540°
	Secs.	Secs.	Secs.	Secs.	Secs.
I	+20.9	+ 2.5	-6.9	- 9.7	- 8.5
II	+22.9	+10.3	-5.1	-10.9	-10.1
III	+26.9	+15.3	-2.5	-15.1	- 9.9
IV	+22.7	+10.7	+2.9	- 7.1	- 6.9
V	+10.1	+ 6.3	+5.3	+ 0.6	- 1.3
VI	- 0.7	+ 1.9	+6.3	+ 8.5	+ 1.7
VII	-16.3	- 3.9	+5.9	+11.1	+ 7.5
VIII	-25.1	- 7.9	+4.1	+12.5	+11.9
IX	-29.1	- 7.9	+1.9	+11.1	+10.7
X	-25.5	- 7.7	-2.1	+ 4.5	+ 5.1
XI	-11.5	- 5.7	-4.3	+ 1.1	+ 2.7
XII	+ 4.9	- 3.3	-5.9	- 6.7	- 3.1

here again between the arcs of 360° and 450° , and that the greatest variations in the long arcs are also again under arcs of 540° , the same as in the flat spring. We have in this last item a very instructive phenomenon, showing, first, that correct terminals do reduce position error; but, second, also, that a cylindrical spring is, at best, little or no better than a flat one with correct terminals.

In the illustration of this last experiment I observe that the major axis of the elliptic figures does not pass through the middle of the first half coil pinned to the collet, as in the case of the previous ones, with the same spring, and as also in the case of the flat springs; in fact, it occupies, with respect to the terminal pinning and the figures of the dial, a position nearly at right angles to

TABLE 10—(see Plate IX.)

Showing rate with the same cylindrical spring as in Tables 7, 8 and 9, under the same conditions, but with terminal pinning of N coils + 270°, the stud being at the Figure V of the dial.

N. B.—The sign + indicates that the rate is losing, and the sign — that it is gaining

Positions up.	180°	270°	360°	450°	540°
	Secs.	Secs.	Secs.	Secs.	Secs.
I	+12.2	+3.7	-2.3	- 5.1	- 5.4
II	- 1.4	-0.1	+0.8	+ 1.3	- 0.5
III	-14.8	-5.5	+2.1	+ 6.9	+ 5.
IV	-24.6	-8.3	+4.6	+10.8	+ 9.
V	-29.8	-6.6	+8.9	+11.3	+10.8
VI	-24.6	-6.9	+3.5	+10.5	+10.7
VII	-13.2	-5.5	+1.1	+ 5.4	+ 6.5
VIII	+ 3.	+0.1	-1.7	- 0.8	- 0.4
IX	+15.8	+3.7	-4.3	- 6.7	- 4.7
X	+24.6	+8.2	-4.7	-11.3	-10.9
XI	+27.	+9.1	-4.9	-12.6	-12.2
XII	+24.4	+8.1	-3.1	- 9.6	- 8.1

that. The terminal curves were an ellipse, the minor axis of which was 0.58 of the major axis, one of Phillips' curves, and therefore the coil at that point was brought nearer the center. From our reasoning on the proper motion of the balance spring (10), illustrated in Figs. 13, 14 and 15, we must conclude that that portion of the spring affects position error most which acquires the greatest momentum during the motion of the bal-

ance; but that is that portion which, at equal distance from the center, moves through the longest arc, or path it traces around the center. That is precisely the portion in the lower coil of the spring, Plate X., through which the major axis of the elliptic curves passes.

TABLE 11—(see Plate X.)

Showing rate with the same cylindrical spring as in Tables 7, 8, 9 and 10, under the same conditions, but with correct terminal curves.

N. B.—The sign + indicates that the rate is losing, and the sign — that it is gaining.

Positions up.	180°	270°	360°	450°	540°
	Secs.	Secs.	Secs.	Secs.	Secs.
I	+11.	+5 8	+1 6	—1.	—1 5
II	+12 8	+5.	+1 9	—0 2	—1.3
III	+ 8	+4 5	+2 1	+1.3	—0 8
IV	+ 1 8	+2 6	+2 4	+0 4	—0 5
V	— 4 3	+0 3	+0 8	+0 4	+0.3
VI	— 9 5	—2 3	—0 7	+1.5	+1 4
VII	— 9.6	—6 9	—2 2	+0.8	+1.7
VIII	—10 2	—7.	—2 9	+0 4	+1 5
IX	— 8.7	—5 3	—2.6	—0 3	+1 1
X	— 1 6	—2.1	—1 1	—1 4	+0 3
XI	+ 2 3	+1 3	+0.3	—1.2	—0 5
XII	+ 7 2	+4 7	+0 9	—0 9	—1.5

It is very evident, however, that different portions of the spring become the center of gravity, and thus the controlling factor, under different arcs of motion; for, not only do the greatest variations of rate not occur on exactly opposite sides of the dial for the same arc of motion, but the major and minor axes of the different curves do not fall on the same figure of the dial exactly. This is particularly observable in the curve representing the rate for the arc of motion of 450°, in which the greatest variation occurs more nearly at the figures 12 and 6 of the dial, while it is least at or near 2 and 8, positions in

which the variations of rate in all the other arcs are greatest. This phenomenon is more marked in the cylindrical spring than in the flat ones. In the latter the same variations in different arcs occur more nearly in the same position of the dial.

It may be asked how we can determine the degree of the arcs of motion of a balance while a watch is running? This is a comparatively simple matter. The illustration, Fig. 24a, will assist us in making it plain: Sup-

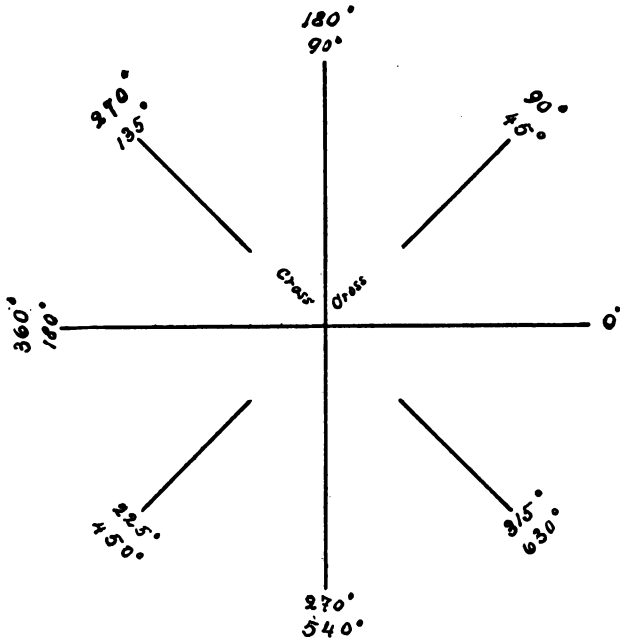

FIG. 24a.

pose a balance at rest and its arms to occupy the position of the line 0° and 180° in the figure. Let us now move it to the angle 45° and let go of it. Under the action of the spring it will return to 0° and to 45° to the other side of it, and it will continue to vibrate between these two points if we suppose the motive power just sufficient to maintain that arc and no more. This gives the balance a full motion of 90° . Again, if we move it to 90°

from its position of rest, it will return to 0° and to 90° to the other side, giving it a full motion of 180° of arc, and so on; if we move it to 135° to 180° to 225° and 270° from its initial position, it will acquire a motion of just double the number of degrees of arc as are contained in the arc of displacement from its state of rest. We now observe that when the balance is in regular motion there is an instant, just when it reaches the limit of the arc of motion and before it starts on its return vibration, when its arm becomes visible. The locating of this instant in space, relative to the angular distance of its occurrence to the position of the arm when the balance is at rest, will determine the degrees of the arcs of motion of the balance. Returning to the illustration we observe that when the balance has a motion of 90° only, the arm at the return of the vibrations occupies such a position in space that it exhibits a cross, i. e., at the end of one vibration it stands in the direction of 45° and 225° and at the end of the other in that of 135° and 315° , the two being at right angles to each other. Again, when it has a motion of 180° , the instant of the return of the vibration, when the arm becomes visible, shows the latter to coincide in point of space, but now in a direction at right angles to the position it occupies when at rest, i. e., in the direction of 90° and 270° . When it has a motion of 270° the arm, at the moment it becomes visible, exhibits again a cross; under a motion of 360° the coincidence of the arm; under a motion of 450° a cross, and under that of 540° of arc the coincidence of the arm again, the latter taking place again at right angles to the position it occupies when the balance is at rest. The résumé of the analysis is, that the coincidence of the arm at the limit of vibration occurs under arcs of motion of 180° and 540° at right angles to the position it occupies when at rest, while under arcs of 360° this coincidence takes place when the arm is in its initial position, and intermediate arcs of motion all exhibiting the arm at right angles at the moment of visibility. These are the cardinal points to go by. Intermediate arcs of motion must be estimated by the greater or less divergence from these, and a little practice will enable us readily to determine the amount of difference, as well as to decide whether a cross indicates a motion of 90° , 270° , or 450° .

12. Practical Deductions.— I desire now to make a few deductions from the results of the foregoing experiments for future guidance in the practical work of adjusting. Passing under review the illustrations on Plates IV. to X., inclusive, the reader will observe as follows:

First: That in all the experiments, whether with flat or cylindrical springs, whether with or without theoretical terminals, the most erratic rates occur under the lowest arc of motion, the elliptic figure illustrating the rate for arcs of 180° being very much eccentric. Next comes the curve illustrating the rate for arcs of 270° . If we eliminate these arcs from the experiments, the average result is very much improved. If, furthermore, we can eliminate the rates for arcs of 540° , the result is still better, for the average rate, for the twenty-four hours, in the worst position, would not vary greatly then. This suggests close attention to the freedom of the train and the perfecting of the escapement, as well as to the quality, manner of attaching, etc., of the mainspring in order to secure the best development of its motive power; for, with a motive power whose force is developed most uniformly, and transmitted to the balance with the least variability, we shall have the least variation in the arcs of motion. Of course, all the time the same arc of motion would not remedy the trouble, for each arc of motion has its own position error; indeed, under the circumstances, it is better that the arcs of motion should vary, say, between 360° and 500° , for then the average rate for the twenty-four hours in the two worst positions will be nearly the same, as is abundantly evident from the experiments, particularly in Plates IV. and V., the short arcs going fast and the long ones slow on one side, and the reverse on the other, thus being in a measure self correcting.

From the very great variation in the rate between long and short arcs it is also evident that trials for position error of less duration than twenty-four hours are not only of no value, but absolutely misleading. The reader will do well to mark this.

Second: The least variation of rate, under all the arcs, occurs at two points opposite each other, a diametral line passing through which passes also through the inner pinning point of the spring, or nearly so. This line is also practically at right angles to the major axis of the elliptic curves, on the line of which the greatest varia-

tions occur. We have thus four points fixed in the position error of the spring, which we must make to coincide with our cardinal vertical positions, viz.: *Pendant up, pendant down, pendant to right and pendant to left.* The points of least variation of rate on the minor axis must be for our pendant to right and pendant to left, and it would be immaterial which of the points on the major axis are selected for either of the other two positions, were it not for the fact that it is better, for reasons that will be made manifest hereafter, that the rate "pendant up" should gain a trifle rather than lose. This consideration makes us choose that side of the major axis for "pendant up" on which the long arcs, or arcs above 360° , are gaining. That point so chosen, the middle of the first half of the inner coil of the spring would stand vertically over the center of the balance arbor, when the watch is "pendant up," or hanging, and the balance is at rest.

There are other features brought out in the graphic representation of the phenomena of position error, which we could not have elicited in any other way, I venture to say. They serve to make us more intimately acquainted with the difficulties and the complicated nature of the problem, rather, perhaps, than as a help to obtain closer results; they enlighten us as to the causes of our failures if they do not help us avoid them. This is not very gratifying, I am aware, but it is better to know it than to be ignorant of it. One of these features is, that neither the major nor minor axes of the elliptical figures, considering them as passing through the center to which the rates are in reality coördinated, pass exactly through the points of the greatest and least variation on either side of the circle. This is particularly visible in the results with the cylindrical spring, without theoretical terminals, in which, as I said before, the effect is very much magnified, but it exists also in the flat spring. From this it follows that, choosing the points above suggested for our cardinal positions, the mean of the rate in opposite positions of the dial will seldom be exactly the same, because the greatest variations do not occur exactly at opposite points, and it would be useless to change the relative terminal pinning of the spring, because we would thereby only shift the error a little in

relative position, but not remove it. It is also plain, as I have stated before, particularly with reference to the graphics illustrating the experiment with the cylindrical spring with theoretical terminals, Plate X., that the major and minor axes of the curves representing the rates under different arcs, taken singly, do not coincide on the same figure of the dial, and that, therefore, our adjustments must suffer slightly from variation in the arcs of motion by whatever they may be caused, and however carefully we may have made the terminals of the spring.

The results recorded in Tables 5 to 11, and illustrated in Plates IV. to X., are, of course, affected by and include the error of the isochronism of the spring, as well as that arising from centrifugal force; but they are those of the actual concrete problem, such as we have to deal with in watches, which is what we desire to know, and which alone can be of any help to us in the practical work of adjusting. They will vary with the state of the isochronism of the spring in different watches, and hence no absolute rule as to the exact quantity of the variations can be laid down that will hold good for every watch; on the contrary, the adjustment of every watch involves an experiment of its own. But we may positively rely on the characteristics of the variations being the same, subject to slight changes in their positions relative to terminal pinning and the cardinal points of the dial.

A very important result brought out in the reduction of the experiments, but not shown in their tabulated form, is the fact that, when the mean rate of the horizontal position is compared with the mean rate of all the vertical ones, the latter is always slower—*i. e.*, the watches lose in the vertical position. I have not observed a single exception to this. The actual difference varies between three and twelve seconds in twenty-four hours. The difference is much reduced by the application of correct terminals to the spring, but never wholly removed. This result cannot be due to any factor inherent to the spring, such as we have been considering, since results arising from this cause in opposite vertical positions would mutually balance each other in the taking of their mean, but must be looked for, as to their source, in the effect of the passive forces, such as the resistances in the

escapement and the friction at the balance pivots, which increase with the diminution of the arcs of motion (4, c and e). In reckoning with this factor, therefore, it behooves us to look to these sources of disturbance and reduce them to their minimum. Of course, the friction at the balance pivots is always greater in the vertical positions, and the fact that the application of correct terminals to the spring reduces the difference in the mean rate between vertical and horizontal positions is due to their reducing that friction.

The reader who has attentively followed the results of the experiments tabulated and illustrated under paragraphs 5, 10 and 11 can scarcely fail now to stumble upon a suggestion which occurs to nearly every one getting acquainted with them, and that is: the application of two balance springs to the same balance in such a way that, the terminal pinnings being the same in each, are placed opposite each other, on opposite sides of the center. Reason at once suggests that, from the nature of the disturbing factors treated on in these paragraphs, this would remedy at once both the error of isochronism arising from difference in terminal pinning, and the position error. I have not followed this suggestion to its utmost promise by investigation. Perhaps some one will. Such experiments as I have made in this respect have not been wholly satisfactory. So far as the error of isochronism arising from terminal pinning is concerned, I have succeeded very well; but position error still existed. This arises probably from the fact already referred to above, that the greatest + and - variations in the rate do not occur at exactly opposite sides of the spring for the same arc of motion, and that their relative positions are shifted with the change in the arcs. One can do something to facilitate the work and improve the result by movable studs that enable us to turn the collets and thus change the relative positions of the springs without changing the angular distance of their terminal pinning. The subject, however, is one for the inventor and manufacturer to look into; for the adjuster and repairer I have suggested in the following paragraph (13) a remedy which is entirely at his command.

13.—A Discovery and a Remedy.—The researches outlined in the preceding paragraphs were made on lines

which, so far as I am aware of, nobody else ever pursued. I believe I have demonstrated beyond a doubt that position error in watches is not due to want of poise in the balance. While I do not claim absolute perfection in the numerical results of the experiments, yet I believe the reader will grant me the claim that I have shown the cause of that error to be the oscillation of the center of gravity of the spring, due to its "proper motion," and that it is unavoidable. I have demonstrated the fact that position error still exists, though in diminished quantity, after the application of the most perfect terminal curves. There would seem to be no further remedy, from the nature of the case; yet I venture to suggest one. If the reader will turn again to the consideration of the "proper motion" of the flat spring (Figs. 13, 14 and 15), it will appear obvious to him at once that, taking the movements of the different coils as represented by the points marked 1, 2, 3, 4, etc., to 12, they should each have a different effect, quantitatively, on the motion of the balance. In fact, the effect they produce must be according to their several momentii. Stated in mathematical language, these are equal to the product of the mass into the length of their path, multiplied by the square of their distances from the center. If, therefore, a weight were placed on the balance spring, the effect of such weight on the motion of the balance would vary according as we placed it on the first, second, third, fourth, etc., coil of the spring. I have ascertained the effect of such a weight experimentally on a given spring.

A piece of platinum wire drawn down to the same thickness as the wire composing the spring, or a trifle thinner, was placed on one of the coils, so as to straddle it, gently squeezed together and cut off below the coil, at the same time twisting it a trifle so as to clinch it on the coil. By this means the weight was made fast enough so as not to slip of itself, and still permit me to move it from one coil to the other by pushing it clear around. The weight was placed on the first outside coil first, then on the second, third, fourth, and so on until it reached the eleventh coil, the spring being composed of a fraction over thirteen coils. The watch I used was a Jules Jurgensen, regulated to mean time, but gaining with the figure VI up, which was, when in the

position of "pendant to left," 10.8 seconds in twenty-four hours, as compared with its rate in "pendant to right." The balance spring was a "Bréguet," with correct outer terminal. The weight was applied on that side of the center of the spring which was up, when the pendant was to the left—*i. e.*, on the side of the figure VI. The gain in the rate "pendant to left" being noted, the weight was placed on the first coil, and the difference in the rate between "pendant to left" and "pendant to right" noted again. Then the weight was shifted to the second coil and the same test repeated, and so on the third, fourth, etc., coils, shifting the weight from one coil to the other, and noting the difference in the rate obtained at each, for the two positions, until it had reached the eleventh coil. For reasons stated above (II, a), the trials were made under arcs of motion of the balance of 440° . The following are the results obtained, the quantities being the reduction to twenty-four hours, and the sign + indicating that the rate was losing, and the sign — that it was gaining:

VI up without w'ght				— 10.8 sec.		
"	with	"	on 1st coil	— 6.6 "	effect	4.2 sec.
"	"	"	2d "	— 0.6 "	"	10.2 "
"	"	"	3d "	+ 5. "	"	15.8 "
"	"	"	4th "	+ 12. "	"	22.8 "
"	"	"	5th "	+ 19. "	"	29.8 "
"	"	"	6th "	+ 20. "	"	30.8 "
"	"	"	7th "	+ 18.2 "	"	29. "
"	"	"	8th "	+ 14.4 "	"	25.2 "
"	"	"	9th "	+ 10.2 "	"	21. "
"	"	"	10th "	+ 6. "	"	16.8 "
"	"	"	11th "	+ 0. "	"	10.8 "

When afterwards the watch was fully wound, so that its arc of motion became from 495° to 500° the repetition of the trial with the weight still on the eleventh coil gave again a gain in the rate "pendant to left" of 8.4 seconds, showing that the effect of the weight was diminishing with the increase in the arc of motion of the balance; and it would cease altogether were the motion of the balance increased to such an extent that the weight itself would move through an arc of 440° . The result of the above

experiment is illustrated graphically on Plate III., Fig. 2, which needs no further explanation.

It is evident from the results recorded in Table 4 and illustrated in Figs. 17 to 24, that position error cannot be remedied by poisoning the balance, nor by putting it out of poise. If we could apply an additional weight to the balance in such a way that its arc of motion should always be considerably less than 440° , when the balance has attained its maximum motion, the problem would be more nearly solved. The foregoing experiment furnishes the proof that that can be done—*i. e.*, that we can apply a weight to the spring, which constitutes part of the balance, in such a way that, no matter what the extent of the motion of the balance may be, it will never attain a motion of 440° . We have in the size of the weight the choice of metal (as to specific gravity), the particular coil on which to place it, and its location with respect to the figures of the dial between which the discrepancies of rate exist, the means to obtain almost any degree of accuracy in correcting it. It is true that such a weight will not adjust a watch to position for all arcs of motion of the balance; but if the motion of the latter is limited between 500° and 360° , which is usually the motion a well-made watch has between windings, the application of a weight to the spring answers the purpose admirably. Of course, if from any cause the motion of the balance should decrease below that, the effect of the weight would increase the error.

As I have stated in the beginning of this chapter, the position error, with an ordinary flat spring, is seldom less than 15 seconds, and more frequently attains as much as 30 seconds in 24 hours. Theoretical terminals, inside and outside, will reduce it to 5 and 10 seconds; but a weight applied to the spring will reduce it, in an ordinary flat spring without terminal curves, as much, and in one with correct terminals to below 5 seconds.

It is, of course, perfectly feasible, and in some instances necessary, to apply more than one weight to the spring, placing them on different coils.

CHAPTER III.

COMPENSATION FOR VARIATION OF TEMPERATURE.

14. Temperature Error.—All substances, and consequently also the metals of which the balances and balance springs are made, expand and contract with the rising and lowering of temperature. One of the effects is that the inertia of the balance (in other words, its regulative force) is constantly varying; hence the variation of rate called temperature error. It is, perhaps, the best understood factor with which we have to deal, because, owing to the great importance attached to it in ship chronometers, it has been studied more than any other.

As early as 1833 E. J. Dent, celebrated watchmaker of London, established the fact, experimentally, that a chronometer, with a balance made of glass, would vary in its rate as much as ten seconds in twenty-four hours for every change of 1° in temperature, going that much slower for every degree the temperature was raised.

In 1859 Delamarch and Ploix, two French hydrographers, experimented with a balance made of brass alone, and found that it would cause a variation in the rate of the chronometer to which it was adapted of eleven seconds in twenty-four hours for every degree the temperature was raised or lowered, going that much slower in the first, and faster in the second case. This is a fact otherwise so well established that at Greenwich, England, a chronometer with such a balance is used as a thermometer in the temperature room where the chronometers are subjected to trial.

This variation of rate is due to three factors:

1. To the expansion and contraction of the balance;
2. To changes in the length of the spring, caused by changes in temperature; and,

3. To variation of the elastic force of the spring, diminishing as the temperature rises and increasing as it falls. By far the greater portion of the variation of rate from changes in temperature is due to the last factor. In fact, taking the case of variations with the brass balance, it has been shown by E. Caspari, in the work quoted above, and by others, that of the 11 seconds variation per degree, 1.55 seconds is due to the expansion or contraction of the balance; 0.52 seconds to the lengthening or shortening of the spring, and nearly 9 seconds to changes in its elastic force. The last factor is absolutely beyond our control in itself. Nor does it seem advisable to produce a variation in the length of the spring by mechanical means to counteract the lengthening and shortening of it by changes in temperature. The consequence is that the only resource left to us is in the control of the expansion and contraction of the balance, which we have in the so-called compensation balance. Unfortunately, however, this, too, fails to meet the case perfectly.

15. Ordinary Compensation Balance.—If the effect of the expansion and contraction of the balance alone were to be remedied, it might readily be done; for it is probable that a balance can be made and its compensating weights so adjusted that its active diameter (and, therefore, its moment of inertia) would remain con-

FIG. 25.

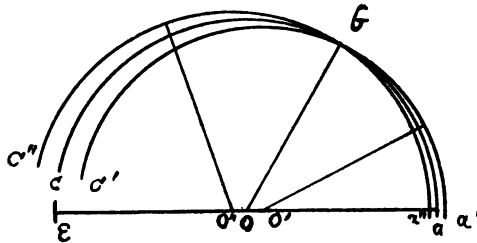

stant during all changes of temperature. When, however, it is intended, as we are obliged to do, to compen-

sate for the effect of all three of the factors mentioned above, the case is different.

For the purpose of conveying a clear idea of the action of and the principle involved in the compensation balance, let Fig. 25 represent one-half of a balance, a o e the bar of steel, o the center, and a b c the rim composed of brass and steel, cut at c. Suppose the temperature to rise, the bar of steel to expand, and its radius o a to become o a'; the rim also expands, and, the brass being on the outside and expanding more than the steel, will bend inward so that, while a has moved to a', further from the center c, the cut end of the rim has moved to c'—that is, nearer to the center.

Again, suppose the temperature to fall, the bar of steel to contract, so that the radius o a becomes o a"—i. e., shorter; the rim also contracts, and, by reason of the greater contraction of the brass part of it, will open outward, so that c will move to c"—that is, further away from the center. During this process the rim remains sensibly circular, but its radius of curvature changes, and its center, o, moves to o' under the high temperature, and to o" in the low temperature. But there is a point, b, in the rim, at some distance from the bar, at which the radius remains unchanged, which moves neither towards nor away from the center during the expansion and contraction of the rim, and which is, therefore, a neutral point, as to the effect of its weight under changes of temperature. An additional weight placed on the rim between the points a and b will cause a loss in the high temperature, while the same weight placed on the rim between the points b and c will cause a gain in the same temperature. This necessarily follows from the construction of the balance and its movement under changes of temperature.

Now, it is evident from the above analysis of the action of the balance that we can adjust the weight of that section of the rim comprised between the points a and b, to that between b and c, in such a way that the mean radius of gyration of the balance will remain the same during its expansion and contraction from heat and cold; in other words, so that its moment of inertia will remain constant during any changes of temperature. Unfortunately, this would compensate only for variations of rate due to its own expansion and contraction by heat

and cold, but not for the lengthening and shortening of the spring, nor for variations in its elastic force. To compensate for the effect of the latter factors, we are obliged to surcharge the section of the rim comprised between the points b and c, with heavier compensating weights, and then we can only partially accomplish the desired result.

If we take the variations of the above mentioned brass balance—viz., 11 seconds per degree in 24 hours, and illustrate the behavior of it by coördinating them to

FIG. 26.

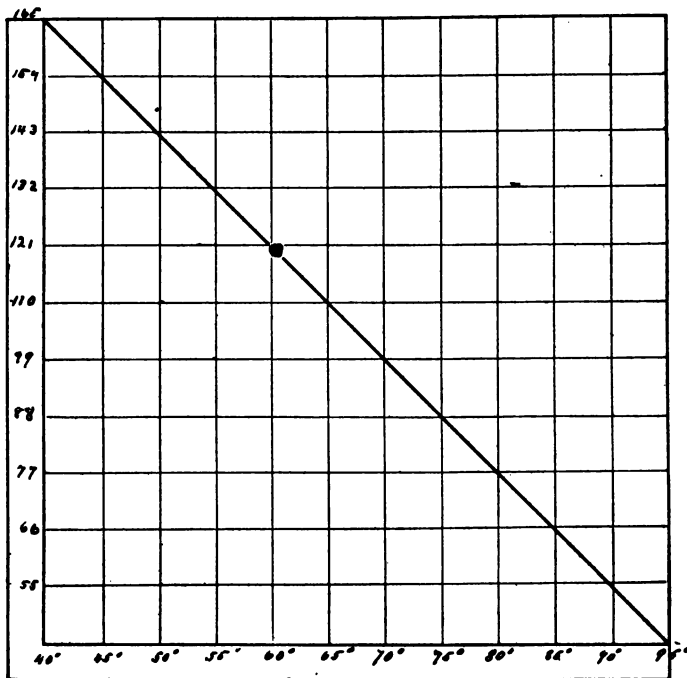

right angular axes, they will produce a uniformly inclined straight line, Fig. 26, the fastest rate occurring at the lowest temperature. To exactly offset that by a compensation balance, we would have to be able to produce

an effect exactly the opposite—*i. e.*, one that would give a uniformly inclined straight line at right angles to it—the resultant of which would be a straight horizontal line. The fact is, however, that the best result we can obtain with an ordinary compensation balance is one which, when coördinated as above, will produce a curve like that in Fig. 27, in which the divisions on the horizontal lines represent temperature, and those of the vertical ones time, or rate. To state the meaning of this curve in plain English: a watch or chronometer will go fastest in some one temperature. In a temperature above or

FIG. 27.

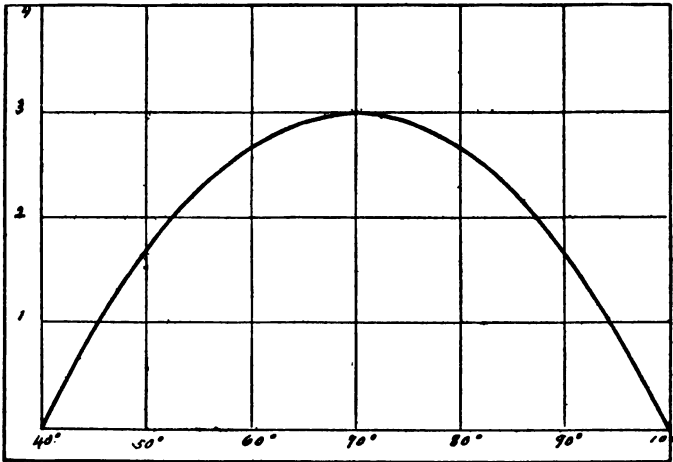

below that it will go slow, and all we can do by changing the position of the compensating weights on the rim of the balance is, to shift the apex of the curve, or the temperature in which it will go fastest to a higher or lower temperature. This, at first sight, may seem very unsatisfactory, but on closer examination it is not so bad.

It is well known from the analysis of the actual rates of chronometers that the curve produced by coördinating them, as in Fig. 27, is a parabola, the origin or apex of which lies in the temperature in which it will go fastest. This temperature being known, it is easy to cal-

culate its rate in any other temperature by the formula giving the equation to the parabola:

$$y^2=4ax.$$

A simpler formula, or at least one more readily understood by those who are not familiar with conic sections, is the following, in use at the United States Naval Observatory: The temperature in which a chronometer goes fastest is called the temperature of compensation. The change of rate, owing to temperature, is least at this point, but increases as the square of the number of degrees above or below that temperature. For an equal number of degrees above or below the temperature of compensation the rate is the same. This being the case, let

r' = the rate at any temperature above or below the temperature of compensation;

r = the rate at the temperature of compensation;

z = the difference between the rate at the temperature of compensation, and that at 1° above or below;

Θ = the temperature of compensation; and

Θ' = any other temperature;

then will

$$r' = r + z (\Theta - \Theta')^2;$$

in plain English: the rate at any temperature is equal to the rate at the temperature of compensation, plus the product of the difference in the rate at 1° above or below that temperature into the square of the number of degrees of the temperature above or below the temperature of compensation at which the rate is to be found.

This formula holds good for a range of temperature of from 20° to 25° above or below the temperature of compensation—*i. e.*, for temperatures as high as 95° and as low as 45° F., if the temperature of compensation is 70° . Above or below these temperatures the rate changes according to higher powers.

I state this formula, not because it has any practical value in connection with watches, for we cannot aspire to such refinement in that branch of horology, the rate

of watches being more variable and not subject to such accurate determination, but because it seems appropriate in any treatise on temperature adjustment, that at least the main principles underlying the determination and use of temperature error in ship chronometers should be given, for we have to depend for the purpose of studying temperature error upon information derived from that source.

As already stated, the temperature at which a watch or chronometer goes fastest is called the temperature of compensation. In ship chronometers this ought to be in the neighborhood of 70° ; but in watches it is advantageously placed at a higher temperature, for the reason that a watch is seldom or never exposed to a temperature below 60° . According to the foregoing definition of temperature error, Fig. 27, a watch or chronometer can be adjusted to run exactly the same in some two temperatures equidistant above or below the temperature of compensation. A chronometer which is adjusted to 45° and 95° will gain from 2 to 4 seconds in 24 hours in a temperature of 70° . The same rule holds good in watches. But if the two temperatures to which they are adjusted are less far apart, the difference in the rate at the mean temperature will be less. By adjusting the compensation in a watch between 60° and 95° we can diminish the error of the mean temperature to less than half the quantity.

The quantity by which a chronometer gains in the mean temperature differs for every chronometer; but the temperature of compensation, and the difference between the rate at mean temperature and 1° above or below that, remain practically constant for one and the same chronometer, and the chronometer may be cleaned and repaired ever so many times, provided its compensation has not been interfered with, without producing any change in them.

16. Auxiliary Compensation.—The characteristic variation of the rate of chronometers, illustrated in Fig. 27, is called "secondary error." The cause of it is not well defined; for, not only does it differ quantitatively in different chronometers, but two balances of the same lot, made of the same piece of metal, and in precisely the

same way, may have widely different curves, the one being flatter than the other. As a rule, chronometers giving flatter curves are preferred, for the ideal compensation would be that which would give a straight line; but no objection is raised in the naval service to one giving a strong curve, provided its rate is sufficiently regular. Many attempts have been made to overcome, or at least to reduce, this secondary error by the application of what is known as auxiliary compensation, but with only partial success. It would be beyond the scope of this work, designed, as it is, for the benefit of the watchmaker mainly, to enter into a description, as well as the merits of the various devices proposed and used to accomplish this end, their usefulness being restricted to ship chronometers. Nevertheless, a statement of the principle upon which they work, or ought to work, seems in place.

By reference to Figs. 26 and 27 we see that with the ordinary compensation balance the chronometer loses in both extremes of temperature. This shows that the effect produced by the compensation is too great in the low temperatures and not sufficient in the higher ones. Returning to Fig. 25, and the explanation there given of the movement of the rim of the balance under changes of temperature, the reader may be able to see why this is the case, and to apprehend the nature of the remedy required. The portion of the rim of the balance comprised between the points b and c, with its compensating weight, moves toward the center in a rising temperature, tending to make the actual diameter of the balance smaller and thereby to make the chronometer gain. The fact that it still loses in the high temperature shows that the weight does not move near enough to the center. Again, under a decreasing temperature, the same portion of the rim moves away from the center, tending to make the balance larger, and thereby to make the chronometer lose. The fact that it goes slow in the low temperature proves that the weight moves too far away from the center; that, in fact, it overcompensates in that temperature. The principle, therefore, upon which an auxiliary compensation should work is that of increasing the effect of the compensation in the high temperature and checking it in the low. To state the work required

of an auxiliary compensation in terms of the mechanics of motion: it must diminish the active diameter of the compensation balance, in other words its moment of inertia, in both high and low temperatures. The ideal form of an auxiliary compensation, therefore, would seem to be that of an additional weight moving toward the center in both extremes, starting from the mean temperature.

Very few of the auxiliary compensations in use fulfil this law; most of them are operative in one direction only. Some of them have the effect of reversing the rate curve—*i. e.*, of making the chronometer gain in both high and low temperatures. One of the worst effects of a bad auxiliary is, that the curve produced by the rate is quite irregular, and, therefore, not subject to any formula for its calculation.

Some years ago there was instituted at the observatory of Geneva, Switzerland, a national competitive trial of marine and pocket chronometers, specially designed to study temperature error and the effect of compensation, including auxiliary compensation. An exhaustive report of this work was published under the auspices of the "Journal Suisse d'Horlogerie" in 1885, the only work of its kind published in which temperature error in connection with watches has ever been treated. The trial was made with 61 timepieces—7 marine chronometers and 54 pocket chronometers. They were subjected to a temperature ranging from 5° to 35° centigrade (41° to 95° F.), during seven periods of five days each; first in a temperature of 5°, then in one of 10°, of 15°, and so on in ascending order of temperatures, five degrees apart; and again in the same way in descending order of temperature from 35° to 5°. The result of this trial is of exceeding great value, well worth the perusal of the reader who desires to study the subject. In this trial the value of auxiliaries was brought out in a prominent way. The result showed that, while they generally diminish the secondary error, quantitatively, they cause considerable variation, producing generally very irregular curves, often crossing and recrossing the line of mean compensation several times between the extremes of temperature. One of the points brought out was the curious freak that the curves produced by the

rates during the ascending periods of the trial differ in many cases considerably from those of the descending periods, some of them being exactly reversed. This seems to be the case particularly with those which had been recently adjusted, while several whose adjustment dated back to longer periods, one of them in particular, which had been adjusted some years before, gave curves almost identical for both ascending and descending periods.

In this trial, account was taken of the difference, as to the effect upon compensation error, between steel and palladium springs, a point which I have not thought worth while to touch upon in the foregoing investigations. It showed that, while, in general, the secondary error was smaller with palladium springs, the compensation curve for the steel springs was more regular and generally parabolic in shape. This could hardly be interpreted as tending to show a superiority in the palladium spring.

There was brought out, too, in this trial, the fact, mentioned before, that two watches made by the same maker, identical in construction, balance and balance spring, gave totally different rate curves. While, therefore, the result of this trial in general corroborated the parabolic form of curve in watches, too, in particular it brought out many irregularities and exceptions. It follows that, even if watches were not subject to position error while being carried, a factor of much greater importance in their case, it would be useless to attempt to apply a rigid formula for the reduction of their rate in variable temperature.

Much may be expected from the use, for balances and hairsprings, of the metal called "nickel steel," recently discovered, one of the characteristics of which is that it is but slightly, if at all, subject to expansion and contraction by changes in temperature.

CHAPTER IV.

APPLICATION OF CORRECT PRINCIPLE IN THE CONSTRUCTION OF WATCHES AND PRACTICAL WORK OF ADJUSTING.

17. Mechanical Defects.—Before proceeding any further we must now turn our attention to the consideration of disturbances which have their origin in mechanical defects; for they must be remedied ere we can expect good results. The principal ones which the repairer meets with are in the escapement."

In the first place the escapement must be "in beat"—*i. e.*, the interval between two successive beats must be of equal duration. This is the case when, with the balance at rest, the jewel pin stands on the line of centers between pallet arbor and balance. We have already discussed (4, c) the unlocking and impulse in the lever escapement. These factors are unavoidable, but their effect can be reduced to a minimum by adherence to correct principles in the construction of the escapement. It is very plain, for instance, that, when the locking angle is too great the disturbing influence resulting from the unlocking is increased. In properly made escapements with steel wheels, $1\frac{1}{2}^{\circ}$ is sufficient, and 2°

(10) The reader should familiarize himself with the principles of the lever escapement by consulting Grossman's "Lever Escapement;" Mr. C. Saunier's works, both translated into English, or the various treatises on the subject published by the Journal Suisse d'Horlogerie, Geneva, Switzerland.

should be the maximum. The smallness of the locking angle permissible depends upon the fidelity with which the wheel and pallets are executed. If the wheel is perfectly true and round and reduced to a minimum weight, and the lifting stones of the proper width, the minimum of locking angle can always be obtained.

Another defect frequently met with which needlessly increases the resistance of the unlocking is too much passage way, or lost motion, of the lever after the tooth has fallen off the lifting stone. There should be just enough to insure the passage of the highest tooth, and that requires very little. In many watches, particularly factory-made ones, we find the impulse table too large, both as to the safety action and the distance of the jewel, or impulse pin, from the center. This invariably necessitates lost lever motion.

Again, too great a draw angle on one or the other, or both, of the lifting stones will increase the resistance to the unlocking. In many of the American watches the slots in the steel frame for the reception of the lifting stones are cut too wide, and the setting of them at the proper angle depends upon the cementing in. This leaves the draw open to the chances of variation. While too much draw angle increases the resistance to the unlocking, on the other hand too little of it makes the locking unsafe, particularly on the entering stone, where the action of the wheel is of the nature of a push, as distinguished from that on the exit stone, where it is a real draw. The latter defect may prove fatal, particularly when the lever is not in poise, or too much out of poise, in consequence of which the fork may fall back, after banking, in some one or the other of the vertical positions, and the guard touch the impulse table. This defect is the more serious, as it is difficult to detect it in the act, and may manifest itself only during the carrying of the watch.

One of the principal conditions to be observed is the proper freedom of the jewel pin in its passage in and out of the fork during the action of the escapement. When the passage way of the fork from one banking to the other has been limited to the least possible to insure safe escapement, the jewel pin, when in the act of passing out of the fork and while standing in front of the

outer corner of the slot should have just enough clearance to pass without touching the corner in any of the positions the watch may be placed in. There should be a little play between the corner and the flattened front of the jewel pin when the fork rests against the banking. It is difficult to say just how much, but one degree motion of the fork would be a safe quantity. It should be the least possible, taking into consideration the side shake of the pivots. Too much play, on the other hand, the passage way of the fork being limited to the proper extent, would result in diminished impulse communicated to the balance, which is also to be avoided.

The weight of the escape wheel, as well as of the fork and pallets, is of vital consideration in a watch, the adjustment of which is to be attempted. Keeping in view the desideratum of getting the greatest motion of the balance with the least motive power, and not forgetting that the latter, at the circumference of the escape wheel, is reduced to an infinitesimal quantity, reason dictates that these organs, more than any other in the watch, should be the lightest possible consistent with proper firmness. All unnecessary weight in them increases the general resultant of defects in the escapement. For this reason a scape-wheel made of steel, which can be made hard and thin, is preferable to one of brass, and much preferable to one made of gold. The lighter escape wheel, fork and pallets are, the prompter and surer will their function be. A heavy escape wheel, moreover, directly increases the inequality of the impulse before and after the line of centers (4, c); for, owing to the draw on the locking surface of the lifting stones, there necessarily results a certain amount of recoil of the wheel during the arc of unlocking of the balance. As this takes place when the latter has acquired its greatest velocity, it throws the wheel back a little further than necessary, so that the tooth does not immediately slide on to the driving plane of the lifting stone on reaching the locking corner, but by reason of its sluggishness lags behind and may reach the plane only when the fork has reached nearly the line of centers, thus diminishing still more the impulse communicated before the balance spring reaches its state of rest. No very close adjust-

ment can ever be obtained in watches with heavy escape wheel, fork and pallets.

Another of the essential points is the size and form of the balance pivots and their proper play. The diameter of a balance pivot should not be over 0.12 of a millimeter in an 18 size watch and not above 0.11 millimeter in one of 16 size. They should be perfectly cylindrical for a length a little more than the thickness of the jewels and the space between the latter and the endstones. Both upper and lower ones should be of the same size and the ends should never be made perfectly flat; yet neither too pointed. It is absurd to want to adjust watches by flattening the ends of the pivots with a view of equalizing the arcs of motion in vertical and horizontal positions. In the first place, it cannot be done by flattening the pivots, as the friction will always be much greater on the circumference than on the ends, and in the second place, if it could be done it would be no advantage, but rather a disadvantage, as we shall see hereafter. The end shake should be only sufficient to insure perfect freedom and all three mobiles, balance, pallet arbor and wheel should have the same amount. The side shake of the balance pivots should not be more than 0.01 millimeter. If it is more than that and the jewels are thin, as is the case in many fine watches, the oil will run out of the holes and the pivots run dry and cut in a little while.

In this connection I would state that it is my opinion, founded on long experience, that many makers of fine watches use balance jewels that are altogether too thin. They do not retain the oil so well. This is the case particularly when the space between end stone and top of jewel is too great, and, as stated just now, when, in addition, the side shake of the pivot is greater than it ought to be. It is difficult to understand why they should use such thin jewels and make the sides of the holes olive shaped at that, which reduces the surface in contact almost to a knife edge. It certainly cannot be that they do it with a view to reducing the friction in vertical positions and with a full knowledge of the law of friction, viz.: that it is independent of the surfaces in contact, the pressure remaining the same. What they really do is to limit the wear and tear of friction to a narrower surface.

After all that has been said on the subject of friction there still seems to exist a confusion in the minds of many between friction as a resistance to motion and the work done by friction in the wear and tear of the surfaces in contact. While the former is independent of the surfaces in contact the latter is inversely proportional to them, the pressure remaining the same, *i. e.*, the work done by friction in the wear and tear of the rubbing surfaces is greater when their extent is reduced. Hence, thin jewels will cut the pivots quicker than thicker ones, and this will be the case particularly when the oil runs away from the pivots. It is a pity that more thought is not given to this matter in the making of balance jewels, which as to form and finish are often real gems of art, but which, owing to their being too thin, are worse than useless for the purpose intended. Of course, the repairer has to take things as they come sometimes without being able to alter them, and to him these reflections may be of little practical benefit except to enable him to connect cause and effect when results are unsatisfactory.

Attention must be paid to the end stones. They should not be too far away from the jewels; 0.03 to 0.04 of a millimeter should be the maximum, and their flat surfaces should be perpendicular to the axis of the balance. If this is not the case differences of rate between "dial up" and "dial down" will be the result.

The poising of the balance should be perfect and should be done on the poising tool. Not only is this the best we can do, but the idea of poising the balance from differences observed in the rate of a watch in opposite vertical positions as practiced by some and recommended by M. Lossier¹¹ is falacious. Position error is no proof that the balance is out of poise (11, a and b and 12). We can indeed, to some extent, correct position error by putting the balance out of poise; this, however, only corrects the error in the highest and lowest arcs; in the middle ones between 360° and 450° it would still exist, and these are just the arcs of motion the balance generally has in vertical positions.

(11) *Etude sur la théorie du réglage*, p. 112.

It may be a matter of surprise to some of my readers that I have not before alluded to the poise, or want of poise, of the lever as one of the factors in the variation of the rate of watches. The fact is that want of poise in the lever, if sufficient to influence the rate at all, can do so only in the vertical positions; in the horizontal positions it is entirely without effect and can therefore not be considered as one of the factors disturbing the isochronism of the spring; not only that, but I am sure that an attempt at poisoning it, if a heavy counterpoise is required, such as is frequently found in watches, is more disastrous through the increased friction caused by the increase of the weight of the lever, for in no part of the watch is the addition or diminution of the weight of the moving parts so important as in the latter. There was a time when the poise of the lever was considered an essential condition by the manufacturers. They applied a heavy counterpoise; often, when required, as in the case of the long forks, at a great distance from the center of motion, unconscious, apparently, of the fact that they were surcharging the already small enough force exerted at the circumference of the scapewheel by giving it more work to do. It became a matter of fashion, the artistic taste taking advantage of it in the production of fanciful and fantastic designs. We have unlearned all this. In the best watches made to-day the counterpoise is dropped entirely, experience having shown that lightness in the lever is of greater importance than its equipose. It should be observed that in a lever reduced to its least weight consistent with a proper firmness, and particularly in the case of short forks, which are now almost universal, the want of poise can never be very considerable. Taking an ordinary practical example, M. Lossier, in the work before quoted, page 49, has shown that a want of poise in the lever, such as may be found in a well-constructed watch, would cause a variation of rate between opposite vertical positions of not more than 0.11 of a second in 24 hours, a quantity entirely neglectable. We may therefore dismiss this factor, as to its influence in the work of adjusting, with the sole recommendation to the workman to look to the freedom and the lightness of the lever rather, and to secure the proper amount of draw on the locking surface of the pallets.

The train of a watch must, of course, be perfectly free and the depth perfect, so that the transmission of the motive power should be effected under the most favorable conditions. To this intent the mainspring as the motive power merits our special attention. The main object to be accomplished is the development of the most uniform power during the interval of two successive windings. We have seen (12) that if we could limit the motion of the balance to a range between 360° and 450° the mean position error would be a minimum. In a mechanically perfect watch this can readily be accomplished by the choice of a proper mainspring and its fastening. This being a very important factor in adjusting, I shall consider it somewhat at length.

Some years ago I had occasion to pass upon the merits of a number of samples of mainsprings from different makers. I constructed an apparatus for measuring, by weight, the development of the force of a spring. I soon found that there was a great difference between springs of different makers and also between springs of the same maker, but differing in price. Among a great many I tested there were only two, the product of two different Swiss makers, that gave anything like a uniform development of force. The measurements were made for every eighth of a turn winding. One of the springs that gave the best result was a hookless one, *i. e.*, a spring that required no hook, sometimes called "slip spring," the outer end of which suddenly became thicker about eight and a half centimeters from the end, so that it braced itself against the wall of the barrel until wholly wound, when the strain produced by further winding caused it to slip. The other was a spring found only in the finest Swiss watches. The discrepancies in the development of the force of the springs led me to make a special inquiry as to the cause of it. I measured the thickness of some of them throughout their entire length for every centimeter distance. The spring which gave the best result, one of the hookless ones, measured for the first eight centimeters from the outer end 0.32 of a millimeter. From that point it rapidly tapered down to 0.19 when about ten centimeters from the end. Then it continued at that until about twelve and a half centimeters from the inner end, when it again gradually in-

creased in thickness until one centimeter from the end, where it measured 0.22 millimeters. The tapering at both ends, as well as the measuring between, was so uniform that it excited my admiration for the painstaking of the man who made it. The measurements of some of the other springs were very irregular, indicating no painstaking on the part of the maker. But I was not satisfied with this test. Desiring to watch the behavior of the springs in the barrel while being wound, I pierced the lid in form of the web of a wheel, which enabled me to look into the barrel at any stage of the winding. There appeared a marked difference in their behavior. While those which gave good results, and particularly the hookless one, wound in regular spirals around the arbor, the coils being more or less separated from each other during the winding, others, and particularly such as gave irregular results, fell to one side of the barrel immediately as I commenced winding them, pressing more or less heavily upon the arbor on one side and against the barrel wall on the other, the coils rubbing hard against each other and only becoming centered again during the last turn of winding. I soon discovered that this feature depended largely upon the manner of hooking the spring to the barrel wall. There was at that time a spring in the market used by one of the watch factories which had what was called a "punched hook," *i. e.*, the spring had at its outer end a tongue punched out which, being pressed outward, hooked into a notch milled into the barrel wall. This tongue would straighten out immediately upon commencing the winding of the spring and press the whole spring towards the opposite side of the barrel. All the springs with this hook gave very bad results in the development of their force; at some stage in their winding it was impossible to determine it, the addition or taking away of weight producing no appreciable difference in the indication of their force. The same was the case, though not quite so marked, with springs that had what is called the "T" hook. None of these springs would wind in concentric spirals around the arbor. The same factory that was using the spring with the "punched hook" had also a spring with what was called "a brace," but which, for reasons of economy, had been discarded. This brace consisted of an additional lam-



ina riveted to the end of the spring just back of the hole, with a lip extending sideways through a notch in the lid, and a free tongue extending beyond the rivets in the direction of the spring. The lamina being riveted to the inside of the spring, this tongue acted as a reinforcement as far as it extended, holding the spring firmly against the wall of the barrel. Springs with this "brace" invariably gave better results as to the development of their force as well as to winding concentrically; in fact, springs that had given very bad results with the punched hook would, on that being removed and the brace put in its place, give as good results as any of the ordinary springs. This experience led me to formulate a rule that, in order to obtain the best development of the force of a spring the outer end of it must be hooked solidly against the barrel wall. The method employed in some of the best foreign watches for holding the end of the spring to the wall by a lamina set inside of the first coil immediately beyond the hook and traversing both lid and bottom of barrel answers the purpose very well; but I believe that the "brace" is still better, inasmuch as the loose tongue of it reinforces the spring and makes it wind more concentrically to the arbor. According to the experience with the hookless spring, there should be a tapering in thickness of a short distance immediately back of the hook to increase its strength at that point and this condition the "brace" very nearly fulfills. A very good development of the force of springs can, however, be obtained without the use of the "brace" by properly hooking it in the ordinary way. This result depends wholly upon the manner in which the hook in the barrel and the hole in the spring are made, and for our guidance we need only consider some of the essential points of a good hooking. In the first place, the hook must be strong enough to resist all strain put upon it when the spring is fully wound. It should hold the end of the spring closely and tightly to the barrel wall. It should be as narrow as possible in order not to require too wide a hole in the spring, which would weaken the latter at that point. A hook made in the old-fashioned way in the screwplate will serve the purpose well. If we make a hook, as shown in Fig. 28, A in plan and B in profile, and a corresponding hole in the spring D, we need not fear that it will ever break or allow



FIG. 28.

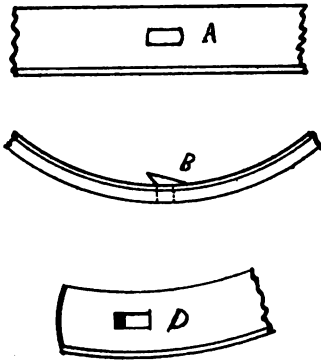
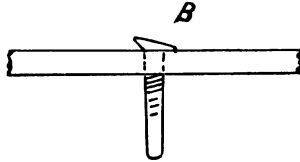

FIG. 29.



the spring to slip. The undercut on the hook should be a trifle steeper than the slant bevel in the hole of the spring, for then the spring would take its hold at the very root of

the hook, close to the barrel wall, and the greater the tension of the spring becomes the closer it will hug it. To make this hook, we select some hole in the screw plate—it need not be a large one, No. 9 of the Swiss plate will do for most watches—and having filed a piece of brass or nickel wire, tapering for a sufficient length to go through the hole free for a centimeter or a little more, we screw it into the hole until a full thread is formed on it. We then cut it off and hammer the large end down onto the plate as shown at B, Fig. 29, file up the front undercut for the catch and the sides, fitting the hook to the hole, previously punched into the spring and beveled, as shown at D, Fig. 28. It will be seen that the hook is made long and narrow and the back of it hammered down close onto the plate so as to act as a brace to it when screwed home against the barrel wall. To enable us to make the hook in the right direction on the wire so that when screwed home in the barrel it will stand just right, a trifling preliminary experiment is necessary—once for any given hole in the screw plate is sufficient if we make a note of it for future guidance: Screw a tapering piece of wire into the hole of the screw plate that is to be used. It is not necessary to form a full thread on it for the purpose. Cut it off, leaving a little of a projection on the large end, and on a level with the surface of the plate make an incision with a screw head file, on the side of the part that projects, noting the direction

in which the incision stands with respect to the cardinal points of the screw plate; then remove it from the plate, screw it into the barrel from the inside and note the direction in which the incision stands in the barrel when flush with the wall. This will guide us as to the direction in which to make the hook on the plate, so that when it is screwed home in the barrel it will stand just right.

To supplement the good office of a hook, a little attention to the end of the spring, in which the hole is made, is necessary. First: do not blue the end of the

FIG. 30.

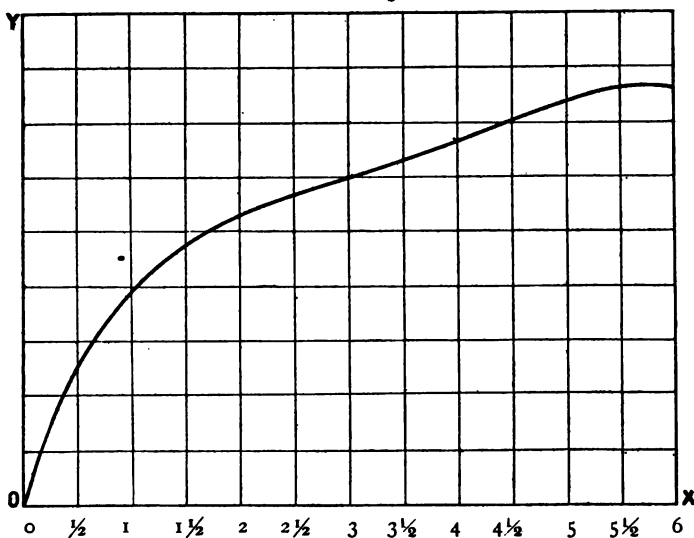

spring further back than necessary; second, punch the hole as close to the hard part as possible; third, leave from one-half to a full centimeter of the spring beyond the hole, and do not make this any thinner by stoning or filing it tapering, more than what is necessary to remove the burr. This end will act as a "brace" against the wall of the barrel when the spring is under tension from winding, and tend to make it hug the wall closer. To insure its catching easily when the spring is put in

this end should be slightly curved, to conform to the circle of the barrel wall. The hook should be only a trifle higher than the thickness of the spring.

There are still other points to be considered in a spring if we want to obtain the best development of its force. In the curve, Fig. 30, we have a graphic representation of the development of the force of a mainspring, from the moment we commence to wind it until it is fully wound, the intersections on the horizontal line $o x$ representing half-turns of the barrel arbor, and those of the vertical line $o y$ units of force as measured by weights. If the force were a constant one it would produce a horizontal straight line. The deviation, therefore, of the curve from such a line measures its variation. The curve is the projection of the force of one of the springs actually tested as above described, and it is one of the best ones. We see that the force increases very rapidly for the first and second half-turns, and even up to the third half-turn. From there on the increase is less rapid and more uniform until we reach the eleventh half-turn, when it slightly diminishes. Other springs I have tested diminish more rapidly after the eleventh half-turn, and even before that, and develop more irregularly during the earlier stages. We see, then, that the development of force we can obtain from the best springs is none too good. Bearing this in mind, it behooves us to utilize if we can only that portion of the force which is the most uniform, and that is the portion developed between the third and eleventh half-turns, which, thanks to the "stop-work," we are able to do. If we set the latter so that one and a half turns of the arbor remain when it is "down," we will eliminate the two extremes of the force, the stop-work permitting of four turns winding only. This, however, necessitates that the spring, without the stop-work, should give not less than six full turns. It would be still better if we could obtain seven turns, for the greater the number of turns a spring winds, the less rapid and generally more uniform, if it is a good one, is the development of its force. We are, however, limited by other conditions: first, the amount of force required to produce sufficient motion in the balance, and, second, whatever the length and thickness of a spring may be, it will give the maximum number of turns to wind only

when the area of the empty space in the barrel is equal to the area the spring occupies. To increase the number of turns, we would have to increase the length of the spring, other things being right; but the last-named condition forbids this, unless we can, at the same time, reduce its thickness. It is, therefore, plainly visible how

TABLE 12.

Showing length and thickness of mainsprings to given number of turns and diameters of the barrel.

No. of turns the barrel will wind.			5½		6		6½		7	
No. of coils in spring when down.			10.7		11.6		12.5		13.4	
Diameter of barrel.	Diameter of arbor.	Width of coils when "down."	Length.		Length.		Length.		Length.	
			Thickness.	Thickness.	Thickness.	Thickness.	Thickness.	Thickness.		
10.	3.3	1.23	295	0.115	319	0.106	344	0.090	369	0.092
11.	3.7	1.35	324	0.126	351	0.117	378	0.108	406	0.101
12.	4.	1.48	354	0.138	383	0.127	413	0.118	442	0.110
13.	4.3	1.60	383	0.149	415	0.138	447	0.128	479	0.120
14.	4.7	1.72	413	0.161	447	0.149	482	0.138	516	0.129
15.	5.	1.84	442	0.172	479	0.159	516	0.148	553	0.138
16.	5.3	1.97	472	0.184	511	0.170	551	0.158	590	0.147
17.	5.7	2.09	501	0.195	543	0.180	585	0.167	627	0.156
18.	6.	2.21	531	0.207	575	0.191	619	0.177	664	0.165
19.	6.3	2.34	560	0.218	607	0.202	654	0.187	700	0.175
20.	6.7	2.46	590	0.230	639	0.212	688	0.197	737	0.184
Quantity by which the diam. of the arbor must be diminished to obtain one more turn d=diam. of arbor.			0.138d.		0.126d.		0.116d.		0.108d.	

important it is to construct watches so that the least motive power is required to produce a given motion of the balance. The thinner a spring the longer it can be, and the greater the number of turns to the barrel, and consequently the more uniform the development of its force.

It is important that we should know the exact length and thickness of a spring necessary to obtain a given number of turns of the barrel; or that we should be able to tell the maximum number of turns a given spring will furnish in a given barrel. For this purpose I have compiled Table No. 12, from an article by L. A. Grosclaude, published in the "Journal Suisse d'Horlogerie," Vol. III. The quantities in the table are applicable to any system of measurement, but the most convenient is the metric system, with the millimeter as unit. The table is calculated on the basis that the diameter of the arbor should be one-third that of the barrel, and that the area the spring occupies should be equal to the area of the empty space. A trial or two of calculation by approximation will show the latter to be equal to the area comprised in a zone inside around the barrel wall of the width of nearly one-eighth of the diameter of the barrel. This is the width of space the spring occupies when it is run down, which is represented by the quantities in the third vertical column. The table scarcely needs any further explanation. Suppose, for instance, that the length and thickness of a spring are required for a barrel whose diameter is 16 millimeters, and which is to give 6 turns: In the column headed by the figure 6 and opposite the figure 16 in the first vertical column, we find

$$\begin{aligned} \text{Length} &= 511. \text{ millimeters} \\ \text{Thickness} &= 0.17 \end{aligned}$$

at the same time, in the second horizontal line over the top of the table, prefixed by "Nos. of coils, etc.," and directly under the figure 6, we find the figure 11.6; this is the least number of coils the spring can have, when "down," in order to give 6 turns of the barrel. The number of coils necessary, if memorized, in connection with the number of turns required, is convenient as a means for readily finding the necessary thickness of a spring without the table; for all we have to do is to divide the inside diameter by 8, and the quotient again by

the number of coils necessary, and we have its thickness. It is not necessary to measure the length of a spring exactly when putting in a new one, for, having chosen one of the right thickness, all we have to do is to slip it into the barrel, before making the hole to see whether it has the right number of coils, and to break off its length until it has that number.

The workman should provide himself with good measuring instruments if he wants to profit by the use of the table. The Denison gauge can be of no help, as no two of them measure alike, and its scale is an arbitrary one.

It may be advisable, or it is possible, at least in certain cases, where it is desired to increase the number of turns of the barrel, to diminish the diameter of the arbor a trifle. For this purpose I have added the bottom horizontal line of figures, by which the diameter of the arbor is to be multiplied; the product will be the quantity by which the arbor is to be diminished to produce one more turn of the barrel. It may be well to add, however, that the diminution of the diameter of the arbor renders a spring more liable to break, or to "set," when its temper is defective. The workman will find that very few watches are constructed so as to permit the dimensions of springs indicated in the table. In most of them the springs are too long and considerably thicker, and—as is the case in almost all American watches, which, as a rule, have no stop-work, occupying more room in the barrel than they ought relative to the empty space, sometimes having as many as 14 and 15 coils, at the same time being thicker than the diameter of the barrel would permit, we can, by making them shorter, invariably increase the number of turns of the barrel, and at the same time make the development of their force more uniform, inasmuch as the coil friction is thus diminished. In this connection, it should be borne in mind that with a poor spring badly hooked, which is the case with many, the coil friction is considerable. Often the substitution of a better hook and the shortening of the spring alone will improve the motion of the balance.

There are certain important considerations to be observed relative to the pinning in of balance springs. They must be perfectly flat and well centered. When the latter condition is fulfilled, the spring, being a spiral, will, upon

being made to revolve with the balance in the calipers, appear to recede from or approach the center, according to the direction in which it turns, with a uniform motion. So long as the coils are wavering, or appear to be stationary on one side, and approach to or recede from the center on the other, the spring is not centered. The centering should be done by manipulating the innermost coil only and close to the pinning point, if possible. The hole in the collet for its reception should be at a proper height, so that it would not be necessary to dress the spring either up or down after it is pinned in. The portion of the spring fastened in the collet should lie in the same plane as the rest of the spring. If these precautions are not observed, there will be differences of rate between "dial up" and "dial down." These recommendations apply equally to the pinning in at the stud. It should not be necessary to twist the spring in any direction after being pinned in; and this applies with even greater force to springs with correct terminal curves.

In flat springs without theoretical terminals care must be had that the innermost coil nowhere touches the collet. For this reason enough must be cut out of the center before pinning it in. Nor should the inner coils, for the purpose of preventing the spring from touching the collet, be crowded together outwardly. Such a procedure would vitiate the entire work. Where this has been done, more must be cut out of the center, the spring pinned in anew, and the balance brought to time by weighting it. The outside of the spring also should be well centered. The spring should be chosen of a size such that the outer coil falls into the regulator pins without crowding it together; it is less mischievous if the outer coil has to be spread out in order to meet the pins. The size of a spring should, in no case, exceed a diameter of one-half that of the balance measured over the outside of the rim. The smaller the diameter of the spring the less will be its position error (3, b).

The regulator pins should be thick enough not to bend under the pressure of the spring. They should be no longer than absolutely necessary, and no wider apart than what is necessary to give freedom without play to the coil lying between them. They should stand parallel to each other.

18. Putting in Balance Springs.—After a watch is in good order, mechanically, the main work of adjusting consists in putting in and adapting the balance spring. This is properly the adjuster's work.

The repairer who may be called upon to adjust watches will find that in most cases the spring already in the watch is good enough, that all it needs is to be properly adapted. As, however, the putting in of a new one involves all the knowledge necessary to adapt an old one, we will suppose that that is to be done.

The first requisite is a sufficient assortment of good springs. For factory made watches this need not be very large, and is readily obtained. A somewhat larger assortment is required for foreign made watches; still the range of sizes really necessary for the latter is not very extensive, and easily obtained if the workman applies for them at the proper sources.

We will suppose, first, that a flat spring without theoretical terminals is to be replaced. The first work is the selection of one of the proper size. The spring should be laid on the balance cock, regulator on, upside down, and centered by the balance jewel. The coil falling naturally between the regulator pins is the limit of its diameter. Next, having taken off the old spring with its collet, stick a piece of beeswax on the balance arbor instead of the collet, and press the new spring on top of it, centering it. Then, taking it with a pair of fine tweezers, by the coil which fell between the regulator pins, proceed to vibrate it, with a good clock, or a well regulated watch, counting the vibrations it makes in a given time. If the required number (150 per minute for a watch beating 18,000 an hour, counting only each double vibration) cannot be obtained on the coil falling between the regulator pins, another spring must be tried, a trifle weaker or stronger, as the case may require. A better way to vibrate a new spring is to compare it, visibly, with what is called a "vibrator." This is a mounted balance, whose spring has been accurately timed. I have used such a balance for many years. It consists of a mounted 18-size balance; an ordinary watch dial with feet, to the seconds hole of which an upright is mounted, consisting of a piece of brass wire, four millimeters in diameter and about a centimeter long, to which the balance cock, with

the balance attached to it, is screwed at such height that the lower balance pivot just touches the polished surface of the dial when suspended by the spring. This balance is vibrating freely in the air without contact with escapement or jewel holes, and therefore approximately realizes the conditions of theoretical isochronism. There is no need of counting the beats with the use of this vibrator. Holding the spring in the tweezers at a point in the coil where you wish to try it, you place the balance to be timed, thus suspended, alongside the balance of the vibrator, noting the relative position of some point on each, as, for instance, the balance arms, and having started the balance of the vibrator, approach the balance to be timed until it touches it, when the motion of the vibrator balance will be communicated to it, and start it vibrating in unison. Withdrawing the balance a trifle, so that it now ceases to touch the vibrator balance, but still resting it on the surface of the dial by the lower pivot, it will continue to vibrate alongside the vibrator, but its time will now be governed by its own spring, and if that is too weak or too strong, it will immediately be manifest to the eye by its falling back or gaining in rapidity of vibration, as compared with the time of the vibrator balance.

When by a preliminary trial with the use of beeswax it is found that the balance can be timed by the coil limiting the diameter of the spring, it is then taken off, the center cut out to admit the collet with plenty of freedom and the spring pinned into it permanently, bearing in mind what has been said in the preceding paragraph with respect to pinning in of the spring. The spring is then placed on the balance again and vibrated as before, this time for definite timing, taking the spring again by the coil falling between the regulator pins, shifting the tweezers on the coil until the two balances continue to vibrate in unison for a long time. Then mark the point at which this occurs as the point at which the regulator pins are to come. The outer coils may now be broken off, leaving enough to reach from the regulator pins to the stud, bearing in mind that the active length of the spring commences at the regulator pins.

The conditions necessary for isochronism in the flat spring and those that govern the adjustment to positions

cannot always be fulfilled together. We have seen (Chap. I, 5) that the isochronism of the spring depends in great measure upon the angular distance of the terminal pinning, more properly speaking, now, upon the angular distance between the regulator pins and the inside pinning point, while the adjustment to position requires that the middle of the first half of the inner coil should stand vertically over the center of the balance arbor when the balance is at rest and the watch is "pendant up" (Chap. II., 11, a and b). It will be seen that the coincidence of these conditions depends upon the design of the watch. Unfortunately, in most of them, owing to the pendant winding, the position of the regulator pins happens to come in the wrong place, as to terminal pinning, when the conditions for position adjustment is satisfied. The latter adjustment, however, is of so much greater importance in watches that, where they cannot both be obtained we must sacrifice the former, *i. e.*, the best terminal pinning; unless, indeed, we take advantage of the recommendation heretofore made (13) of applying a weight to the spring in order to correct position error, in which case it will make no difference in what relative position the terminal pinning of the spring stands in vertical position and we can pin the spring in at the angular distance most favorable to its isochronism. Those who will try this will find it the shortest and surest way of adjusting the flat spring. The only objection to it is the danger of the adjustment being disturbed if it should chance to get into the hands of a repairer ignorant of the purposes it is intended to serve. But this danger exists always in the case of any adjusted watch. The analysis we have made of position error enables us to always tell beforehand on which side of the spring the weight has to be applied; but as the variations differ, quantitatively, as well as to exact position in different watches, it is always well to make a trial first, as hereafter shown.

In order to make sure of the position of the inner pinning being in the right place for position adjustment—when no weight is desired to be placed on the balance spring—it is well to make a sketch on the bench paper before us as follows: Draw a line, A B, Fig. 31. Lay the movement dial down on it so that it passes through the stem and the center of the movement. Locate the

position of the balance with respect to this line and draw right angular axes E F and C D through it, C D being parallel to A B. Locate the position of the stud S with respect to the center of the balance and draw line o S. Then lay the spring, now colleted, on the right angular axes, centering it by their intersection o, in such a way

FIG. 31.

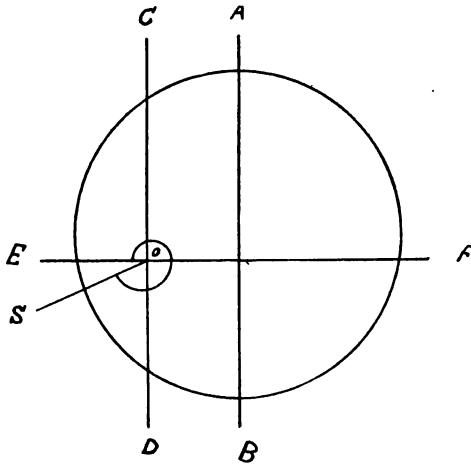

that the inner pinning point falls on the horizontal line E F, with the first half coil above it, and pin it into the stud at the intersection of the line o S and the outer coil. The position occupied by the first half of the inner coil is the same for a spring wound in the reverse direction, only reversed, and it is independent of the relative position of the stud. The view presented in the figure is from the side of the movement.

It is obvious that in thus pinning in the spring to make it come right for position adjustment we cannot always make the point in the outer coil, marked as the point at which the balance will run to mean time, coincide with the relative position of the regulator pins when the regulator stands in the middle of its index. The balance must therefore be brought to mean time either by weighting it with timing washes (20), or by making it lighter, as

the case may require. If position adjustment is to be accomplished with a spring already pinned in and it does not satisfy the above conditions for that adjustment, it is better to unpin it in the center, cut out enough to satisfy the conditions, repin it, and retime the balance as above directed; for, if we simply turn the collet and repin the spring in the stud the change will involve a much longer piece of the spring and the balance will require greater alteration to bring it to mean time again. It is always better to make the spring shorter in such a case, for then the retiming of the balance can be done by timing washers laid under the screws, which is a very simple work, and if practiced as hereinafter directed will seldom necessitate the removal of the balance from the watch. The addition of washers, enough to bring the balance to mean time, for a shortening of the spring of half a coil or more on the inside, does not increase the weight of the balance to such an extent as to sensibly diminish its arcs of motion. In cases where timing washers should not be sufficient to bring the balance to mean time or where the balance should require to be made lighter, a more convenient plan is to provide ourselves with an assortment of balance screws differing in weight in order to time the balance. For American watches we can readily obtain them, with more difficulty for foreign ones.

Having put in a spring in the way above described for position adjustment, well centered and leveled, true in every respect, nothing more can be done in a flat spring to secure the adjustment except by the manipulation of the regulator pins, as hereafter described. We can, indeed, by deviating from the above rules as to the relative position of the pinning point, change the relative rate between the positions "pendant up" and "pendant to right or left," and many adjusters abroad do that in order to obtain the harmony of the rate in these cardinal positions, but it is evident from what we have seen (II, a and b, 12 and 13) that *the position error is not thereby reduced much less removed, but simply shifted to some other position of the dial.*

19. Formation of Theoretical Terminals.—The process in the selection of a spring intended for theoretical terminals is the same as for the ordinary flat

spring, only in the preliminary test in wax we must make allowance for the cutting out of the center of from three to four entire coils, more than would be necessary for the collet, in order to make room for the inside terminal curve. On the other hand, we are not limited as to the outside diameter of the spring by the distance from the center of the regulator pins. Still, we should adhere to the rule not to make the diameter of the spring greater than half the diameter of the balance measured over the outside of the rim.

The method I have pursued for making the inside terminal curve is directly the reverse in process from that by which the outside terminal is made. In the case of the latter, the elements of the curve are determined by the outside diameter of the spring; but in that of the inside curve I find the diameter of the opening to be made in the center of the spring from given elements of the curve. The reason for that is obvious; for the outside terminal, the diameter of the spring, on which its elements depend, is given; not so for the inside one. Here the unknown quantity is the diameter of the opening to be made, which stands in the same relation to the inside curve as the diameter of the spring holds to the outside one. I can find that by establishing the elements of the curve first. Invariably, in putting in a spring, the inside terminal curve must be made first. This curve is invariably that of Figs. 5 and 6, as the simplest and easiest to make. I start from the diameter of the collet. The freedom of the curve and the necessity of manipulating it after the spring is pinned into the collet requires that it should stand off from the latter at a sufficient distance, so as to be able to get between it and the collet with the point of a fine pair of tweezers. I find that from two to three-tenths of a millimeter is necessary. Having measured the diameter of the collet, I divide it by two, and add 0.3 of a millimeter to its radius. This gives me the radius of the first 83° of the length of the curve (7, Fig. 5), and this I know is $0.67 R$, R here being the radius of the opening required. Dividing, therefore, the radius found for the first 83° of the curve by 0.67 gives me the radius of the opening to be made.

Perhaps an application of the rule to a practical example may help to fix the process in the mind of the reader:

Suppose the measured diameter of the collet is	= 2.	millimeters
Its radius, therefore,	= 1.	"
Add to it	0.3	"
	<hr/>	
Radius of first 83°	= 1.3	"
	<hr/>	
Divide by	0.67	"
Radius of opening required	= 1.94	"
The radius of the rest of the curve— <i>i.e.</i> , the		
180° of arc = 0.835 R.		

Multiplying, therefore, 1.94 by 0.835, we have, radius of the rest of the curve = 1.62 millimeters. These are all the elements required.

Now, my method for applying these elements in the formation of the curve in the spring itself is to make a drawing in red ink on a clean sheet of writing paper, in the actual size of the curve. I use red ink on account of the contrast of colors between the drawing and the spring, which enables me better to see differences when comparing it. It may seem a difficult task to make so small a drawing on paper which shall have the required accuracy; but I know of no means whereby the curve can be made except by making a drawing first and imitating it, and this drawing must necessarily be made in the actual size of the curve to do that. On trial it will be found not so difficult as it may seem, and to work admirably, provided the workman has good drawing instruments, and will follow my instructions. A pair of small compasses with screw adjustment, a straight ruler, a protractor and a drawing pen is all that is required. But the centering foot of the compass must terminate in a fine needle with a point ground to an angle of about 30°, and perfectly true and sharp, so that it will not slip, nor yet dig a hole through the paper; and the point of the pen must be in good order. The only other accessory is a good linear measurement divided into fractions of millimeters. I use the metric system simply because the necessary measuring instruments cannot be obtained in any other,

Being provided with these instruments, draw a straight horizontal line. From any point in the line as a center, mark off, with a protractor, 83° , Fig. 6. Through it and the center draw line $u v$ produced to the other side of the horizontal line. With the radius of the opening in the center of the spring draw a circle, represented by the broken circle in Fig. 6. Now set your small compass accurately to the radius of the first 83° of the curve and draw it, starting at the horizontal line as the point at which the end is pinned into the collet. Then with the radius of the rest of the curve and from a center somewhere on the line $u v$ produced, draw the remainder of the curve, comprising the 180° , so that it will coincide with the circle drawn at the intersection of the point v of line $u v$. For subsequent use in centering the curve when the spring is colleted, you may also draw a circle with the radius of the collet and the drawing is complete. It will be observed that the latter part of the curve is just half a circumference and that therefore its radius is just half the distance between the point v and the point where it joins the first part of the curve, on the line $u v$.

Having selected a spring that will vibrate the balance to mean time approximately as described above, we begin by cutting coils out of the center, section by section, until the opening is such that by holding it over the drawing it embraces the circle drawn for it as in Fig. 6,

FIG. 32.

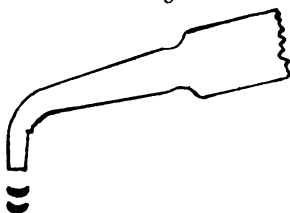

coinciding with it at the point v , with the end long enough to form the curve, including the straight part to be fastened into the collet. We next proceed to form the curve commencing at the point v . As we do this it is well to mark the spring at the point coinciding with the point v ,

so that we have a means of comparing it always in the same relative position with the drawing. The marking can be done by making a slight scratch on top of the coil or on the outer flat side. The bending of the spring must be done very gradually and carefully; not abruptly so as to produce kinks. It should be done with tweezers represented by Fig. 32, bent to an angle for greater con-

venience, one of the jaws being hollowed in the form of a crescent, and the other rounded to fit into the hollow. The workman should have two sizes of these tweezers; one a small one with thin jaws for use on the inside terminal, the other of a larger crescent, which may have thicker jaws, for the formation of the outer curve.

As the work of forming the curve progresses frequent comparison with the drawing is necessary; this is done in the following way: Lay the spring on a clear piece of mica or isinglass, turn and push the isinglass with the spring on it without disturbing the latter so as to present it vertically over the drawing, making the mark on the spring for the beginning of the curve and the point *v* in the drawing to coincide every time, at the same time centering it by the circle drawn for the opening in the relation in which the spring stands to it in Fig. 6; then, looking down on top of the spring and the drawing, we can see exactly to what extent the curve coincides with the curve in the drawing and where it needs bending, if any. I use isinglass as a vehicle because it is the thinnest transparent medium we have. If we used common glass our comparisons would be subject to parallax. The interposition of the isinglass enables us to center the spring perfectly over the drawing by moving, not the spring, but the isinglass with the spring on it, while the space produced between the spring and the drawing by its interposition admits enough light to enable us to see both separately and distinctly.

When the curve in the spring coincides with that in the drawing up to the point where it is to be pinned into the collet, then from that point the end must be straightened and bent approximately in the direction which it will occupy when it is pinned in. It will be found necessary, for want of room in the opening of the spring, to cut and straighten the end out by degrees as we shape the curve and begin to see where the inner end will come, for the terminal must at no time be bent out of the general level of the rest of the spring. I find the dressing of the inside curve can be done most conveniently by laying the spring on a thick piece of plate glass; then, with the tweezers illustrated in Fig. 32 the terminal can be

manipulated easily without bending it out of flat with the rest of the spring.

If the curve is thus far formed, if it lies perfectly flat, with the straight end on the same level plane as the rest of the spring, it may then be pinned into the collet subject to conditions heretofore established (18). For this purpose the hole in the collet must be reamed out large enough to admit the spring freely. Have on hand some fine silver wire to make the pin of; file it smooth, and tapering a little more than the reamer used in order that it may be pushed out easily if that should be necessary. Make it flat on one side by filing down one-third of its thickness; push the collet on a hardened taper holder ground smooth; put the spring into the hole by holding the taper horizontally and follow it with the silver pin, filed as above, turning the pin to level the spring; then, cutting off what projects of the pin on the small end close to the collet and on the large end a little longer than necessary, making sure now that the spring stands flat and level on the collet, push the pin home, using for that purpose a pair of tweezers with rather flat jaws but very sharp, so as not to risk slipping, resting one of the jaws against the collet on the opposite side of the head of the pin, the other on the pin, thus pushing it in, and cut it off smooth on both ends with a small sharp cutting pleyer made expressly for that purpose. After the spring is pinned into the collet the work of final centering comes in. This must be done by bending the spring, not along the curve just formed, but only at the origin of it, either at the point *v*, where it joins the spiral, or where it issues from the collet. As far as possible the rest of the curve must not be touched, unless on final comparison with the collet now on it should be found to deviate from the drawing. The work of centering may be commenced while the spring is on the taper holder—which may be made of a piece of steel wire of convenient length so as to be held and turned in the hand—but the final centering can only be done with the spring on the balance itself, revolving the latter between the points of the calipers. As it is next to impossible to form this curve and not twist the spring the least bit out of the level, a little retouching in that respect may be necessary; but this

should be done very carefully, verifying the correctness of the curve afterwards.

The outside terminal of a flat spring is made in the same way and, except in very rare cases, we can always use the same curve as for the inner one. If the distance of the regulator pins is not such as that particular curve requires, we can always change it by bending the pins to make them either closer to or further from the center. To do this properly, however, care must be taken to bend them close to the surface of the regulator and then make that portion of them between which the curve will play perpendicular and parallel again, so that at no time it will come in contact with their slanting portion.

Having finished the inside curve, trued and centered the spring, we place it, now colleted, on the balance and proceed to vibrate the latter in the manner heretofore described, to find the length of spring which will run it to mean time; this only preliminarily and for the purpose of determining the coil that will limit the outside diameter of the spring and we then proceed to form the outer curve at such a point in the coil that the inner pinning point will be properly oriented for position adjustment.

I am aware that it is stated by good authority (among others, by M. Lossier) that in a balance spring, with correct inside and outside terminals, the orientation of the pinning points can be chosen "*ad libitum*;" but this is a mistake. I have positively demonstrated that position error still exists in spite of the most perfect terminal curves, and that it manifests itself in the same relative positions of the spring, at least in the flat one, as when the terminals are not theoretical curves. For this reason I adhere to the rule of pinning in for position adjustment that we followed in the case of the flat spring without theoretical curves.

Here, again, I make an exception if we use a weight on the spring to correct position error (13). In that case we may pin the spring into the stud in such a way that the point in the outer coil at which the balance vibrated mean time, coincides with the position of the regulator pins. As to the matter touching the most favorable angular distance of terminal pinning, that is of minor

importance in a spring with correct terminals, and may be neglected.

Having got that far in our method of pinning in the spring, the next thing is to find the point in the outer coil at which to commence the terminal curve. For this purpose draw before you right angular axes C, D, E, F, Fig. 33. Let O coincide with the center of the balance

FIG. 33.

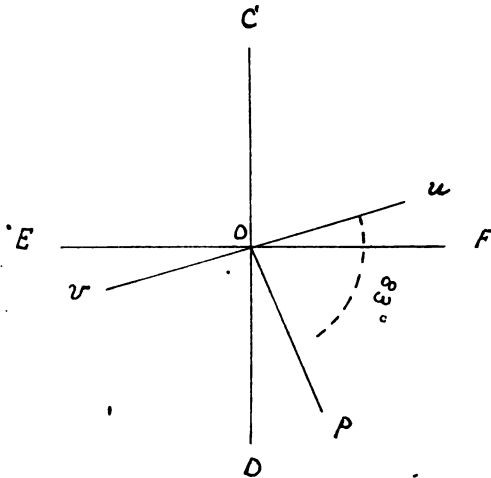

and C D be parallel to a line passing vertically through the pendant and the center of the watch, C being at the pendant. Mark the position of the regulator pins P with respect to the center o and the axis C D, and draw the radial line O P. From this line lay off 83° in the direction in which the terminal goes, starting from the regulator pins (in an open face, generally to the left; in a hunting case, generally to the right of the pins, looking at it from the movement side), mark the angle off by a point u, and draw the line u v. Now lay the spring, coiled, on the drawing, centering it by the intersection of the axes C, D, E, F, in such a way that the inner pinning point will fall on the horizontal line E F, and the first half of the inner coil be above the line, on the side C, as in Fig. 31; then will the intersection of the

radial line $v o$, with the outer coil, mark the point in the latter, at which the terminal should commence. Mark this point by a slight scratch on top or side of the coil.

A drawing must now be made in the actual dimension of the curve, in red ink, the same as we did for the inner terminal.

Draw a horizontal line, $u v$, Fig. 5. From any point in the line as a center, lay off 83° in the direction in which the curve runs on leaving the regulator pins, as viewed from the movement side. Next, from the same point as a center, and with the actual radius of the spring, taken at the point marked for the beginning of the curve, draw a circle. The radius of the spring is found easiest by measuring its diameter and dividing by two. Find the radii of the curve by applying the same elements used in the case of the inner terminal and given in connection with Fig. 5, only in the reverse order—*i. e.*, multiply the radius of the spring by 0.67, the product will be the radius of the first 83° of the curve commencing from the regulator pins; multiplying it by 0.835 will give the radius of the rest of the curve—*viz.*: 180° of arc; with these radii, draw the curve as in Figs. 5 and 6. We may, if we choose, also draw a circle a trifle larger than the diameter of the collet; this will enable us to center the spring more accurately on the drawing for the purpose of comparing the curve. Next, we proceed to raise the outer coil above the level of the rest of the

spring. This is done in various ways by different workmen. I have constructed a pair of tweezers, the jaws of which are represented, enlarged, in Fig. 34. One of the jaws, broad and flat, has four short pins of brass; the other, narrow and thin, slightly rounded on

FIG. 34.

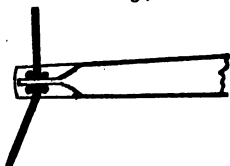

the inner side, fits longitudinally between the pins, while the coil to be bent lies crosswise between the pins, as represented in the figure. With these tweezers the coil is readily lifted without marring the spring. The lifting should commence some distance beyond the point marked for the beginning of the curve, not less than from 5 to 6

millimeters, or nearly a quarter of a coil, and should not be too rapid; and the coil must be leveled again with the rest of the spring before reaching the mark for the beginning of the curve, for the latter must not commence in any portion of the knee thus formed. The part of the knee must be a perfect spiral, and not closer to, or more separated from the next coil than it was before bending it. The coil being thus lifted and leveled again, we can proceed with the formation of the curve in the same manner described for that of the inner one, using for this purpose the tweezers represented in Fig. 32, bending the spring gently by degrees to the proper form, making frequent comparisons with the drawing in the manner stated before, always making the mark on the spring for the beginning of the curve coincide with the point in the drawing where the curve leaves the circle, and centering it carefully. While manipulating the curve we may hold the spring with another pair of tweezers that must have very narrow points, in order not to flatten the coil where it is held. The height of the knee and the level of the curve are much a matter of taste; provided the curve stands free from the rest of the spring from its very beginning, it is immaterial, except as to looks, whether it rise gradually from the level of the knee or lie perfectly flat parallel to the plane of the spring; provided furthermore that the portion which the regulator pins command, and from that to the stud, lies horizontally. For convenience, the angular distance from the regulator pins and place of the stud may be included in the drawing, and the curve, which is a circle, continued to it.

If for any reason we cannot use the form of curve represented in Fig. 5, we must select one from Plates XI. or XII. The curves in these are drawn for different distances of the regulator pins, and in eight different sizes of springs, the same form being used for all the sizes, the position of the stud, as well as that of the regulator pins, being indicated in the drawings. We select one that comes nearest the size of spring and distance of regulator pins we have to match, and proceed in the formation and comparison of the curve in the same way as above. For greater convenience in the use of them the workman may cut these plates out, for he requires to have them lying flat before him. The use of these curves will be found convenient in cases where we merely

wish to correct a terminal in a given case without unpining the spring at the stud, as in a watch that comes to us for ordinary repairs, and which we desire, nevertheless, to improve.

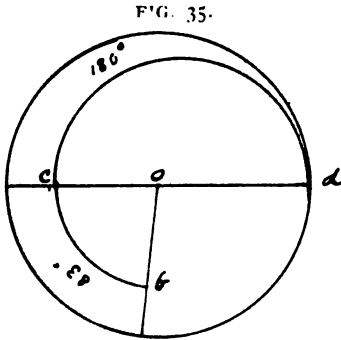

If an outside curve is to be made without paying attention to the orientation of the inner pinning point in view of position adjustment, a somewhat different method must be pursued

for finding the starting point of the curve. We have, in this case, to take our measure from the point marked on the outer coil at which the balance vibrated mean time, the point which should fall between the regulator pins, and in order to know at what point we should commence to lift the coil for the knee and to locate the point where the curve leaves the outer spiral, we need to know the length of the curve. To this end we have to perform a trifle of a calculation.

Supposing that we wish to make the curve represented in Fig. 5; we have to find, Fig. 35, the circular measure of the portion *bc* plus the portion *cd*. The circular measure of

$$bc = \frac{2 oc \times 3.14 \times 83}{360} \quad (1)$$

and that of

$$cd = \frac{(oc + od) \cdot 3.14}{2} \quad (2),$$

the latter being just half a circumference. Taking an example in practice, suppose the diameter of a spring to be

$$= 8.8 \text{ millimeters,}$$

its radius would be = 4.4 “

and according to the elements of the curve we wish to make

$$oc = 4.4 \times 0.67 = 2.94.$$

Substituting this value for $o c$ in equation (1) we have for the circular measure of the portion of the curve

$$b c = \frac{2.94 \times 2 \times 3.14 \times 83}{360} = 4.25 \text{ millimeters,}$$

and in equation (2)

$$c d = \frac{(2.94 + 4.4) 3.14}{2} = 11.52 \text{ millimeters}$$

and for the entire length,

$$b c + c d = 4.25 + 11.52 = 15.77 \text{ millimeters}$$

We may now measure off this length by taking hold of the spring at the point marked for the regulator pins and straightening the coil out gently with another pair of tweezers, sliding along the spring and holding it against a scale; or we may convert it into degrees of circular arc as applied to the outer coil of the spring and commencing from the point marked for the regulator pins, and mark the coil at the point enclosed by the angle as the point at which the curve commences as it leaves the outer coil, and then lift the coil and proceed with the formation of the curve, as in the previous case. There can be no harm in straightening out the coil to get the length of the curve, nor can there be any objection to making a slight mark on the spring to indicate the starting points of the curve. We are obliged to resort to some means of staking off the length of the curve, otherwise we would be working in the dark.

Of course, the length we obtain in the foregoing calculation is that of one form of curve only—viz.: that of Fig. 5; and if a curve should be selected from plates XI. and XII., such a calculation would be impossible, as we do not possess the elements of any of those curves. In that case we would be obliged to resort to trial by approximation. As a matter of fact, however, I may state that, for two springs of equal diameter, the length of the curve does not vary very much, whatever may be its form, so that we can take the above type as a basis of calculation.

It is sometimes desirable to convert a plain flat spring into a "Bréguet" with correct terminals without changing the position of the stud or that of the regulator pins. This can always be done without much trouble, provided

there is room enough under the balance bridge for the overcoil, by adopting the form of curve in Fig. 36 for the outer terminal. This is a curve composed of two quadrants of a circle connected by a straight line, and therefore its elements are simple and known, and a drawing can easily be made of it in the actual size. The quadrants a b and c d are drawn with a radius of one-half the radius of the spring, and it must be borne in mind that, owing to the form of the spring being a spiral, the radius o a differs from the radius o d by half the space between two coils. The radius o a is that of the distance of the regulator pins from the center, and the latter must stand exactly at the point a, of the beginning of the curve, when the watch runs to mean time.

With red ink, draw a horizontal line a d. From any point in the line as a center, and with radius o a, draw

FIG. 36.

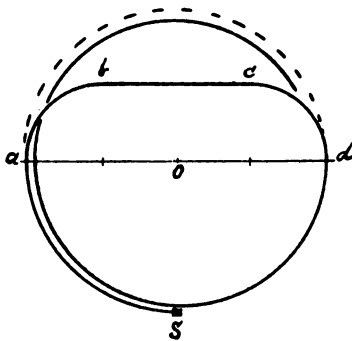
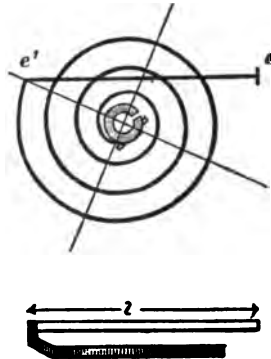

FIG. 37.



circle s a, s being the position of the stud. With the same radius, less one-half the space between two coils, mark radius o d. Bisect o a and draw quadrant a b; bisect o d and draw quadrant c d. Connect them by a straight line, and the curve is complete. For the convenience of centering the spring on the drawing when forming the curve, complete circles may be drawn through points a and d, as well as of the diameter of the collet. This curve is theoretically correct, and will give as good results as any. Its length is readily found, and

the point for the beginning of it at *d* determined, *a* being the point at which the spring vibrates, mean time. Its length is practically one-half the circumference of a circle whose diameter is equal to the radius of the spring, plus the length of the straight line *b c*, which is practically equal to the radius of the spring. The only change to be made in the stud when applying this curve to the flat spring is that of drilling a new hole in a little higher position, or possibly changing the stud if it cannot be raised. Of course, the inside curve can always be made in the manner heretofore explained.

A writer in the "Deutsche Uhrmacher Zeitung," No. 11, 1895, Mr. George Bley, contributed a new form of outside terminal, which is a perfectly straight line, raised, in the manner of Bréguet, over the rest of the spring, of which Fig. 37 is a copy in plan and

FIG. 38.

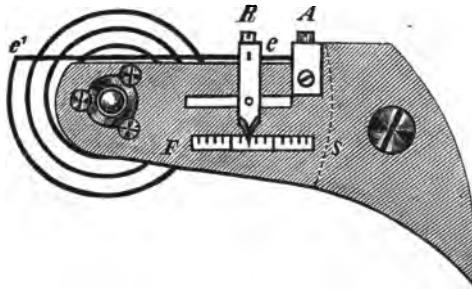

elevation. The data to be found for the formation of this terminal is the length of the straight part, and the angle it subtends with the spiral at the point where it is deflected from the outer coil. M. Bley determines the latter by finding the diameter of the circle to which the terminal straight line is tangent when properly bent in. The formula he gives for finding the length of the terminal is:

$$\frac{\text{diameter of spring}}{0.9102}$$

and for the diameter of the circle to which it is tangent:
 diameter of spring \times 0.4142

For regulator, Mr. Bley suggests one moving in a straight line on the balance cock, alongside of which he would have the straight terminal to lie as in Fig. 38.

The skill required to make terminal curves correctly, particularly the inside one in a flat spring, is considerable. It is not to be expected of a novice; and he who does possess it has probably experience enough to need no further instruction; indeed, it would be difficult to give it in writing. The only means for doing more would be the practical demonstration at the bench.

When the terminal curves are made and the spring centered and leveled on the balance, we may proceed to time the latter approximately to mean time. It is not essential that its rate should be very close as yet, for, in order to make comparative trials of any kind, it matters not how much a watch varies on mean time; nor is it important that the balance should be in perfect poise when making trials for isochronism and temperature error, as the watches in these trials are running in a horizontal position only. It is, however, essential in all trials that the regulator should stand in the middle of its index, for that is the position in which it is supposed to be when figuring the length of the terminal curve, and when assuming that the regulator pins stand at the outer beginning of it. This condition should be constantly kept in mind in the retiming of the balance during the entire process of adjusting, and it should be the existing condition when the work is done, and the balance vibrates mean time. The regulator should only be moved for infinitesimal changes in the rate of the watch when it is being carried.

20. Timing Washers.—A word may now be said in regard to timing washers and how to make them; for the workman will find that he will have to make them himself, the washers found for sale in the market being the merest trash, wholly unfit for the purpose. Besides, he will need some of varying weight, of different diameters, according to the diameters of screws found in different balances. The holes also have to be of different sizes to fit the various sizes of screws. The first thing necessary is a series of punches, of sizes embracing all the sizes of screws to be met with in balances. It is very important that the holes in the washers should fit the

screws; otherwise they might destroy the poise of the balance. In Fig. 39 is represented a punch, washer and screw considerably enlarged. The punches should be made of steel wire, not less than 6.5 centimeters long by

FIG. 39.

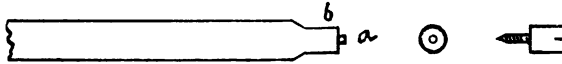

2 millimeters thick. The punch end must be hardened and tempered, and ground to size; that of the projection *a* to the thickness of the screw, and part *b* to that of the head. Both front faces and sides should be ground fine or polished with a lap, so as to produce sharp cutting edges. It will be found that about two sizes are all that are required for American watches (16 and 18 size), but for foreign watches we need three or four to cover all the sizes of screws. However, I do not make a punch until I find I need it, and then I make it to the size of screw I have in hand. In the course of time, I have thus acquired a series of six punches.

A further accessory to the making of timing washers is a block of tin, some five or six centimeters in diameter, if circular, faced flat and smooth. The material of which I make most of the washers is platinum foil. I buy this in sheets of one to two millimeters in thickness, about a centimeter wide, and in any length I may find sufficient for a supply. This I roll out myself to various thicknesses, from 0.1 to 0.025 of a millimeter, preserving a strip of each of four or five different thicknesses. Besides the platinum foil, I also use, principally for poising balances or close timing when the balance has no mean time screws, a thin brass foil, thinner than the thinnest platinum foil. I make the washers only when I need them, so as not to unnecessarily use up my platinum foil, and I have a memorandum on each strip of its thickness, which obviates the necessity of remeasuring them every time I want to make a washer.

The method of making them is the following: Lay the required foil on the tin block at a smooth place; hold the punch in the left hand close to some previous punching, and with a hammer give it a sharp blow, so as to send it through the foil. The washer will be found

sharply cut and flat on the end of the punch, and, on withdrawing the latter from the foil, will fall off. From time to time it becomes necessary to face off anew the tin block, as it gets full of holes.

These washers are put under the screws in the balance by removing the screw and slipping them on the screw part, and then replacing them in the balance. For the purpose of removing and replacing the balance screws conveniently, the workman should have a screw-driver, made on purpose, with a sleeve over it, which will slip over the head of the screw and retain it. The sleeve should be split longitudinally, so as to make it a little springy. By this means the screws can be removed and replaced without the necessity of removing the balance.

21. Orderly Proceeding with the Work—When we have arrived at the stage of our work where the watch is in good order, as judged by the preceding analysis and criticism, the balance spring in place and fitted to our entire satisfaction, the principal part of the work is done. And yet that which remains will consume the most time.

We may now make the first trial for isochronism. Here the workman should commence a complete record, not only of the rate of the watch or watches he is working on, but of all the changes he may make which the results of the trial dictate. This record should be kept in a book for that purpose, or, if kept on fly leaves, these should be kept together and preserved, so as to furnish a complete history of the work done on the particular watch to which they relate. Indeed, if he is a repairer, and is attempting to adjust a customer's watch, he should begin this record before he does anything to the watch at all; he should commence a complete trial for isochronism, for position error, and, if convenient, for temperature error. Such a record, aside from its practical value in guiding him as to what is necessary to be done to the watch, will be a source of pleasure to him, enabling him to show what he has accomplished by his work. It will have an educational value for him which it would be difficult to overestimate. Times without number have I been able to make an unruly watch give satisfaction to its owner by a single touch with a pair of tweezers. A fine watch had chanced to fall into the

hands of an unskilled workman, ignorant of the true functions of the regulator pins. Intentionally or otherwise, he had opened them, changing thereby the isochronal adjustment of the spring, and producing irregularities in the rate of the watch, which manifested themselves in altered and increased position error. A preliminary test for isochronism quickly revealed the cause, and the simple closing of the pins was sufficient to restore the watch to its former trustworthiness. The workman who will follow this advice will be surprised to find how infinitesimal a quantity is sufficient, in the opening of the pins, to make a great change in the adjustment, or, indeed, to destroy it altogether. We want to find out what a watch is doing before we commence to work on it. Not only is it important to make such preliminary trials with watches that have been in use and come to us for repairs, but when dealing with new ones coming fresh from the factory—in these days, when most watches, from five dollar ones upward, are claimed to be “fully adjusted” by advertising “hustlers”; you want to know to what extent these claims are trustworthy before you back them up to your customers who, by the way, will hold you responsible for their truthfulness—and I promise you, begging permission to use a popular phrase, a great “eye-opener.” But we must not allow ourselves to be led away from our thread by this digression, tempting though it is, and fruitful as it might prove in educational results.

We begin our test by winding the watch and setting it, or noting the difference in time between it and some good standard. And here I must be allowed to digress again for a moment: In order that we may be sure of what our watches are doing, we must know what the standard we are comparing them with is doing. If it is a clock or ship chronometer, it should be compared daily, at least, with the time signals that are furnished by the government through the Western Union Telegraph Co. If that is not conveniently obtained, some other equally accurate means should be employed in order to secure correct time.

In a practical test for isochronism, it is not necessary to take account of the arcs of motion of the balance, as we did in the experiments for research, except to note

once for all the limits between which they range from the time the watch is wound until it needs winding again, and it may be well to risk a repetition here, of what we have already discussed (12) in relation to the range of arcs of motion between which the best results are obtained in position adjustment; they should at no time fall below 360° nor go above 540° in vertical positions. It would be vain to expect anything like close agreement in the rate in positions if they range either above or much below this limit. If on a trial this should prove to be the case, and all the recommendations we have made as to the conditions to be established in the escapement, etc., have been attended to (17), we must replace the main spring with one a trifle stronger or weaker, as the case may require, and see to it that it be perfectly free and wind concentrically in the barrel. If the balance pivots are properly made, the ends slightly rounded, the arcs of motion, in the horizontal positions will, and should, be greater than in the vertical ones by from 40° to 50° , which we shall find advantageous in subsequent adjustments (22).

After the watch is set we allow it to run for six hours, at the expiration of which a comparison is made and the state of the watch noted. Then we need not compare it again, unless we wish to do so, until the twenty-four hours after winding are up, when another comparison is made and noted, and, without winding it, we allow it to run six hours longer, at the end of which a third comparison is made. The rate of the watch between each observation is then separately computed for twenty-four hours. This, it will be seen, enables us to make a comparison between its rate during the first six hours and that during the last six hours—*i. e.*, between the longest and the shortest arcs of motion the balance will have, as well as for arcs between these.

As a means of conveying a clear conception of the method proposed for making the trials, as well as the record to be kept of them, I will follow the record of an example in my own practice. There is no necessity for an elaborate time sheet printed for the purpose; a simple consecutive narrative, with such abbreviations as are commonly understood, will answer all the purposes.

We begin by stating the name of the owner and the

number, origin and grade of the watch to which the record relates.

The watch to which the following record relates was the product of one of our American watch factories. It had then but recently been sold, but was new, and was sent to me to have the adjustment overhauled. It was one of those marked in the price lists as first quality, seventeen jewels, "accurately adjusted to temperature, isochronism, and *six positions*" (the italics are mine.) At the head of my record of it I find the following note: "Regulator pins wide open; regulator out for slow; balance spring moving eccentrically; balance true; staff pretty good; pivots too pointed."

Test for Isochronism:

1896.			
Feb. 4	12	noon set	+ 0.
" "	8	P. M.,	- 4.2 rate in 24 hrs. — 12.6 sec.
" "	5	8:45 A. M.,	- 10.6 " " — 12. "
" "	"	11:45 " "	- 11. " " — 3. "
" "	"	8:15 P. M.,	- 9.4 " " + 4.5 "
" "	"	10:15 " "	- 8. " " + 16.8 "
" "	6	7:30 A. M.,	+ 8.6 " "

Difference between the longest and shortest arcs 29.4 seconds in 24 hours, going that much slower in the short arcs.

I desire to state here that I use the plus and minus signs in the sense that the sign — indicates that the watch is fast by the quantity before which it stands and the sign + that it is slow by the quantity before which it stands. At the close of this work (24) will be found a statement of my reasons for so using them.

According to this interpretation of the + and — signs it will be seen that the watch was gaining 12.7 seconds in 24 hours during the first eight hours after winding, and losing at the rate of 4.5 seconds during the eight hours following the 24 hour cycle. During a further run of two hours without winding it was losing at the rate of 16.8 seconds in 24 hours, making a difference, on comparing this rate with that of the first eight hours of 29.4 seconds. The watch had no stop work, and at 7.30 A. M. of the third day it was still running, though with a motion of

barely more than 90°, but a comparison of its time with that of the standard showed that it was 8.6 seconds slow, having lost 16.6 seconds during the last nine hours. The record shows that during the 24 hours between two consecutive windings the watch would vary 9.6 seconds, due to anisochronism of the vibrations alone, which, as proved by subsequent results, was wholly due to the regulator pins being open. I may state, too, that this was an original condition of the watch, as it had never been touched after leaving the factory. Besides, the regulator pins stood perfectly parallel to each other, just as they had, no doubt, been intended to be.

Without making any changes of any kind, I continued the test in vertical positions, but now running it full 24 hours between comparisons; and I may repeat here, what I have intimated before (12), that all trials of any kind except those for isochronism should embrace the full cycle of 24 hours in order to furnish reliable data.

In my records of trials in positions I use abbreviations for the positions which I beg to submit to the reader's approval. The following is the set for the six positions, and hereafter I shall use them instead of writing out the words:

For the words "dial up" I use the sign	\bar{O}
" " " down "	O
" " pendant up "	\bar{O}
" " " to right "	$O-$
" " " left "	$-O$
" " " down "	\emptyset

Following is the record of the trial in vertical positions:

1896.		Difference.
Feb. 6—11.30	A. M., watch was + 22.6 sec.	
" 7 11.30	" \bar{O} + 13.	— 9.6 sec.
" 8 11.30	" O + 8.4	— 4.6 "
" 9 11.30	" \bar{O} + 27.4	+ 19. "
" 10 11.30	" $O-$ + 45.	+ 17.6 "
" 11 11.30	" $-O$ + 61.8	+ 16.8 "
" 12 11.30	" \emptyset + 79.	+ 17.2 "

Note: "On taking out the balance and putting it on "the poising tool it was found considerably out of poise "—motion of balance very good, arcs never below 440°."

Here was a remarkable phenomenon: A watch, the vibrations of whose balance were so far from being isochronal, giving so nearly the same result in the four vertical positions, while there was a difference of more than 28 seconds between vertical and horizontal positions. My suspicion was therefore at once aroused that the balance may have been purposely put out of poise in order to make the vertical positions agree in rate; hence the note above quoted from the record, which testifies to the correctness of my suspicion. This was a watch, claimed to be "accurately adjusted" with a difference in rate between long and short arcs of more than 29 seconds, and between dial up and pendant up of 28.6 seconds. Of what benefit was the agreement in the rate between the four vertical positions?

The balance, as stated in a note at the head of the record, had a good motion; in the horizontal positions it was greater than 540° . There was risk even of its re-banking and I should not be surprised if that, at times, was the case, and added its disturbing element to the unreliability of its performance. They were obliged, in order to adjust the vertical positions by putting the balance out of poise, to maintain a good motion with a strong mainspring. Naturally the difference in the rate between vertical and horizontal positions is accounted for by the anisochronism of the vibrations, the short arcs going so much slower and the arcs in vertical positions being always shorter. This might have been remedied by closing the regulator pins as it was afterwards remedied by myself; but this remedy seems not to have occurred or not to have been known to the people who claimed that it was "accurately adjusted."

I could not do better in the interest of the reader who wishes to gather information for practical use than follow the record of this example to the end. As I was instructed to put the watch in first-class order and adjust it irrespective of what it might need, and as the time at one's disposal in a repair job is always limited, I proceeded without further trial to make the repairs I considered necessary. The next memorandum in my record is the following:

"After making new balance arbor, equalizing holes in

“both balance jewels, making inside and outside theoretical terminals to the balance spring, closing regulator pins and timing balance, latter not yet poised:

	SEC.	IN 24 HRS.
“March 5—12 noon, set	± 0.	
“ “ 5 10.45 P. M.	— 6.8	— 15. sec.
“ “ 6 9.30 A. M.	— 16.	— 20.5 “
“ “ 6 12.15 P. M.	— 19.	— 26.1 “

This was the first trial for isochronism after the repairs above stated were made. It now shows a gain of 11 seconds in the short arcs in comparison between the first and last period of the 24 hours, whereas before there was a loss of 9 seconds between the same periods. This being unmistakable I discontinued the test and opened the regulator pins a trifle, whereupon the following was the result:

	± 0.	IN 24 HRS.
“March 6.—12.45 P. M., set	± 0.	
“ “ 6. 12. midnight	+ 9. sec.	+ 19.2 sec.
“ “ 7. 8. A. M.	+ 15.2 “	+ 18.6 “
“ “ “ 12.15 P. M.,	+ 18.4	+ 18. “
“ “ “ 7.15 “	+ 24.4 “	+ 20.5 “
“ “ “ 8.45 “	+ 25.9 “	+ 24. “

Here we have again a slowing of the rate in the short arcs, consequent on opening the regulator pins.

Although the rate was now pretty nearly the same during the 24 hours, yet, considering that it was running in horizontal position, and that the arcs would be considerably shorter in vertical ones, I, nevertheless, thought it wise to close the pins again a trifle.

I should state here that the opening and closing of the pins necessary to produce these changes is so trifling that the reader who has not made the experiment would be surprised by the result; the actual amount is scarcely visible under an eye-glass.

To open the pins, the workman should make a little tool consisting of a piece of steel wire about 3 millimeters thick and 10 centimeters long. At one end he should file a tongue forming a tapering lamina 3 to 4 millimeters long, not over 0.6 millimeters wide, and tapering in its

thickness from 0.5 millimeters to nothing at the point. This tongue or lamina must stand at an angle of about 30° to the handle part. Fig. 40 represents such a tool from the side and top. The idea of this little tool is to enable us to reach down under the regulator and between the pins above the coil of spring that lies between them,

FIG. 40.

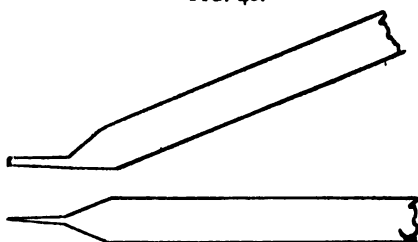

so as to spread them apart without interfering with the spring, nor, indeed, with the motion of the balance. The tongue should be hardened and tempered and ground smooth on all sides, and it should never be used for anything else.

The closing of the pins is done with a pair of tweezers, also especially made, with the jaws bent at an angle of 30° or more, so as to enable us to reach under the regulator, straddle and close the pins without interfering with the motion of the balance.

To return to our example: After closing the pins the result, for the last time, was as follows:

Mar. 7,	9	P. M.,	set	± 0.
"	8,	8	A. M.,	-2.2 rate in 24 hours = -4.8 sec.
"	"	12.15	P. M.,	-3.2 " -5.5 "
"	"	3.45	"	-3.9 " -4.8 "
"	"	11.30	"	-5.6 " -5.2 "
Actual rate for the 24 hours				-5.06 "

This was a close enough agreement, with a tendency to a gain in the short arcs, which was what I desired, and I left it at that.

It may be asked how we can determine a difference of a tenth of a second in timing a watch. That is a matter of practice. We know that a lever watch beats five times in a second, and it is comparatively easy to tell on which of the beats the coincidence with the beat of a clock or

chronometer takes place. With a little practice, we can soon tell, too, when the beat of the clock falls between the beats of the watch, and between which of them in the course of the second. When this is the case, the time of the watch must differ from that of the clock or chronometer by some whole number plus a fraction of a beat. One whole beat being 0.2 of a second, half a beat would be 0.1, etc.

In the trial for temperature error, the example we have been following came out satisfactorily. I will, therefore, not cite that part of the trial, but illustrate the "modus operandi" later, by quoting from the record of another watch.

The balance of the watch was now thoroughly poised, and timed to mean time, the movement cleaned by washing it, and fresh oil supplied to the pivots, etc., and then trials for position error commenced.

As a rule, when dealing with new watches, they should run more than one day in one and the same position, for the reason that the first day's rate, after a change of position, is not always a true index of its average rate. As, however, this prolongs the trials considerably, time for which is not always at our disposition, particularly not in the case of a repair job, we are sometimes obliged to forego this rule. Moreover, it is not well to make critical tests too soon after cleaning, as a watch will run differently with fresh oil from what it does when the latter is two to three weeks old. Indeed, the best results can be obtained only after the oil is from six months to a year old. It is therefore better, if we can, to delay the trials. In the meantime, the balance can be thoroughly regulated, either by timing-washers or by the mean-time screws, if it is supplied with the latter; never, however, by moving the regulator, for, as we stated before, the latter should, in all cases, stand on the middle of its index when the adjustments are finished, and it should only be used for some slight touches after the watch is being carried, and it ought to be made so that it can be moved mechanically by means of a fine screw, by what is called "patent regulator." When timing-washers are used, the balance screws can be removed and replaced by means of the sleeve screw-driver, spoken of above, without taking out the balance; for, after a watch is cleaned, it is

not wise to take out the balance unless absolutely necessary, as the oil at the pivots is apt to become contaminated with dust. If that should be necessary, the pivots should always be cleaned by pushing them into hard pith before replacing the balance. The putting on of timing-washers under the screws will not interfere with the poise of the balance, if they are properly made, as we always place one under each of opposite screws. It is true that considerable skill and a delicate touch are required to do this, but it is the watchmaker's business to acquire these. I must here warn the reader against trusting to mean time screws for the purpose of bringing a balance to time without verifying the poise of it afterwards; for these are seldom of uniform weight and, if moved considerably, may disturb the latter.

After a delay of two weeks, during which time the watch was constantly running and being regulated, the first trial in positions came out as follows:

"Mar. 22, 12.30 P. M., state of watch	+	5.	sec.			
" " 23, 12.30 "	+	6.6	"	+	1.6	sec. $\bar{0}$
" " 24, 11.30 A. M.,	+	4.6	"	-	2.	" $\bar{0}$
" " 25, 12 Noon,	-	6.	"	-	10.6	" $\bar{0}$
" " 26, 12.30 P. M.,	-	20.	"	-	14.	" $\bar{0}$
" " 27, 12.10 "	-	33.2	"	-	13.2	" "
" " 28, 12.30 "	-	54.6	"	-	21.4	" $\bar{0}$
" " 29, 12.30 "	-	63.4	"	-	8.8	" $\bar{0}$
" " 30, 12 Noon,	-	71.	"	-	7.6	" $\bar{0}$

I quote this in full as a sample of a record to be kept giving the date, the time of day when comparisons were made, the difference between the watch and the clock and the rate deduced from them, with the symbols for the positions at the end.

We observe quite a difference in the rate between the vertical and horizontal positions. This difference is, however, just the opposite in sign now from that existing in the preliminary trial, and is wholly due to the closing of the regulator pins. The arcs of motion of the balance are always considerably shorter in the vertical positions, and although in our last trial for isochronism the rate was pretty nearly the same for the short arcs, yet the latter showed a tendency to gain. This is apparent in the

above result. I therefore opened the regulator pins a trifle and repeated the trial, with the following result:

April	Time	P. M.	state of watch	+	I.	sec.		
"	17,	12.20	"	+	0.8	"	-	0.2
"	18,	1	"	+	0.8	"	-	0.
"	19,	1	"	+	0.8	"	-	0.
"	20,	1	"	-	3.4	"	-	4.2
"	21,	1	"	-	7.	"	-	3.6
"	22,	12.30	"	-	17.	"	-	10.
"	23,	1.15	"	-	15.4	"	+	1.6
"	24,	12.40	"	-	15.	"	+	0.4

We now see that excepting in the position pendant to right the difference between the rate in horizontal and vertical positions is very much reduced. This is due to the opening of the regulator pins; and I may add that I have never had a case in which I could not make the rate in vertical and horizontal positions agree by simply manipulating the regulator pins. This could not be done, however, if the arcs of motion of the balance were the same in both positions. The reader may get an idea from this of what use we can make of the regulator pins in adjusting, as well as of the disastrous consequences if they are disturbed after once having been adjusted.

But the difference between "pendant to right" and "pendant to left" still persists, as in the previous trial, and is too great to be allowed to pass. A note appended to the last trial shows that I had taken out the balance to examine its poise, but found it perfect. This difference therefore had its source in some local factor that I had not yet discovered, and which possibly might be difficult to remove; or it may have been due to a residual imperfection in the spring greater than ought to exist, possibly in the formation of the inner terminal; for, according to what we have seen of the manifestation of position error (9 to 11) and the manner of taking advantage of it (12), there ought not to be such a difference in these two positions. I felt averse to re-commence the adjustment of the spring, so much the more so as, so far as was visible, its function was all that could be desired. As I have before intimated there is a time, when, though we have not reached perfection, we must be satisfied with the results we have got, and try and do better next time. All who have made experiences such as a watchmaker has to make will sym-

pathize with me in this. I had, however, still another source of help left open to me; I could use the poising weight on the spring (13), and without looking further, I resorted to it in this case. I have already described the method of applying it. The weight was placed on the second coil from the outside, and in that position, relative to the center of the spring, which was vertically over the balance arbor, or nearly so, when the watch was in the position of "pendant to right" (O-). The next result, without any change, was the following, omitting the repetition of all but the rate and position:

O	+	1. sec.
O	-	1. "
O	+	1. "
O-	-	2.6 "
-O	+	1.6 "
O	+	4. "

I called this good enough and allowed it to pass. No doubt I could have made the agreement between "pendant to the right and left" still closer by shifting the weight on the next coil or by putting on one a little heavier; but as the two principal positions, "dial up" and "pendant up," were satisfactory, and the agreement between the others was within 5 seconds, it seemed not worth while to make the effort. Besides, one risks to overdo the matter when differences are so small, and the result is otherwise so close to perfection.

This example illustrates the mode of procedure in position adjustment as well as the use of the poising weight on the spring. While I might cite many others, equally illustrative of the principles I have endeavored to explain, I believe this one will suffice to give the reader an idea of the work and the result of their application. The work of adjusting to isochronism and positions is done principally in putting in the balance spring, the watch being otherwise in good order. If that is done right the result should be satisfactory. It is a saving of time when putting in new balance springs, or adjusting old ones, for position adjustment, to exert one's best effort in the first instance. If we take proper pains in making the drawing for the curves, and do not rest until we have the exact form of them transferred to the spring in the manner I



have described (17), the result, except for some local disturbance extraneous to the spring, will be satisfactory. At any rate, we can do no better, and should do no less, than make the spring, the pinning of it into collet and stud, as well as the terminals, as perfect as possible. The idea of resorting to deformation of the curves, or excentration of the spring in any way, to accomplish position adjustment or isochronism, is contrary to sound principles and should not be entertained. If we cannot trace abnormal discrepancies to mechanical defects, and have done the best we know how with the spring, we should let them pass or resort to the means I have indicated in the above example.

If, after we have put in a balance spring, or changed an old one to adjust it for positions, we have brought it up to approximate isochronism, it is then ready to be adjusted to temperature.

The adjustment to isochronism must precede temperature adjustment, because in passing from one temperature to another the arcs of motion of the balance will change, and if the isochronism of the spring were very defective the result of temperature trials would not be a true index of the temperature error, and our work in that particular would be defective.

It is customary in factories and with many watch-makers here and abroad to make the rate of a watch agree in the extremes of temperature, say, in those of 40° and 95° . This necessitates both a refrigerator and an oven. I think this method unwise, for reasons already stated (14). Since we cannot obtain uniform rate in all temperatures, and since the middle temperature error is smaller when the extremes are less far apart, and since watches seldom ever get into a temperature below 60° —and if they ever do, the fact can be taken account of in the record—it seems to me more sensible to adjust them to a mean temperature, say, 68° to 70° , and that of 95° . This will obviate the necessity of a refrigerator. A watch so adjusted will not vary over 2 seconds in 24 hours in any temperature between these; and if it should ever get into a temperature below the mean, we know what it will do. A watch adjusted to a mean temperature and that of 95° will lose from 8 to 10 seconds in 24 hours, in a temperature of 40° . There is a further reason

for dispensing with the refrigerator: In passing from one extreme of temperature to the other, moisture frequently condenses on the movement, which, if it happens on the balance spring, may rust and destroy its usefulness.

For an oven, we must have the means for maintaining automatically an even temperature. One very convenient for the repairer is made by Mr. Logan, of Waltham, Mass. It is a foot high, made of nickel-plated sheet tin, with a close compartment, five inches cube divided by a perforated shelf, capable of containing a dozen movements, visible through a glass front. The heat supplied is from a gas jet, the flow of which is regulated by a compound lamina in the interior of the compartment. A thermometer in the interior and visible through the glass shows the temperature. I have had such an oven running for weeks in all seasons of the year without any visible variation in the height of the column of mercury.

For the convenience of making changes in the location of the screws on the balance and keeping a record of them, I have adopted a system of numbering the screw holes, commencing with the one opposite the arm and denoting it by 0, the next one on the rim by 1, the next by 2, 3, 4, etc., the highest number denoting the hole at the end of the rim near the cut. One numeration covers both halves of the balance rim, and in noting the changes made in the record the symbols used embrace both, as always the same changes are made in both. To illustrate, and to suggest a formula for the reader's use, I will give a copy of an example in my practice:

This is from the record of a new watch that had never been adjusted:

	Difference in the high tempera- ture.
"April 12, 11.30 A. M., set to $\frac{+}{-}$ 0.	
" " 13, 12 Noon, temp. 62° — 12.4 sec. — 12.4	
" " 14, 12.30 P. M., " 95° — 56. " — 43.6 — 31.2	
(8—7) (14—11)	

This means that the watch, having been wound and set to correct time on April 12, had gained by the next day 12.4 seconds in a temperature of 62° F., which latter was

the mean of the readings by a maximum and minimum thermometer. Then the watch was simply wound and put into the oven, when, on comparing it again on the 14th, it proved to be 56 seconds fast, having gained 43.6 seconds in a temperature of 95°. The rate of the watch in the temperature of 62°, subtracted from its rate in the temperature of 95°, gives a gain in the latter of 31.2 seconds, the small difference in the time of the comparisons not being taken note of.

In order to avoid error and secure facility of inspection and comparison of results, the result should be carried out as in the formula—*i. e.*, it should always be stated in the same temperature, as in the above,—31.2, instead of + 31.2; for, if we should state it in the latter form, although perfectly correct, or if we should state the result sometimes in the high temperature and sometimes in the low, in which latter case the above result would have to be written + 31.2, it might lead to confusion and mistakes in making changes in the position of the screws. It is, therefore, wise to acquire the habit of stating the result in the same temperature always.

The symbols in brackets [8—7] [14—11] indicate the changes I made in the position of the screws, and mean that I have moved the screw that was in the eighth hole to the seventh, and that which was in the fourteenth to the eleventh hole, on either side of the rim, of course. The sign between the figures has no algebraical meaning, but is simply an abbreviation, arbitrarily adopted for the word “to.”

It will be seen that I moved two of the screws on each side from the cut end of the rim towards the arm. As the watch was gaining in the high temperature, in which the rim of the balance contracts, and the cut end approaches the center, it showed that the weight was too far beyond the point b, (14, Fig. 25,) where it had too much effect, hence the necessity of moving the screws back. The subsequent tests will now be plain. They are as follows:

“April 16,	1	P. M., set to	± 0.
“ “	17,	1 “ temp. 68°	— 30. sec. — 30.
“ “	18,	1 “ “ 95°	— 82.4 “ — 52.4 — 22.4 sec.
		(10 — 2)	
“ “	19,	12 Noon, set to	± 0.

"April 20, 12 " temp. 68° — 28. sec. — 28.
 " " 21, 12 " " 95° — 57. " — 29. — 1. sec.
 " " (6 — 3)
 " " 24, 12.50 P. M., set to ± 0.
 " " 25, " temp. 69° — 12.2 sec. — 12.2
 " " 26, " " 95° — 16.4 " — 4.2 + 8. "

Hitherto I had moved the screws from the cut end of the rim towards the arm; but the last change proved to be too much, inasmuch as the rate in the high temperature was now slower than in the low by 8 seconds. I therefore made the following change:

(4—5)

and the result was:

"April 26, 2 P. M., set to ± 0.
 " " 27, 1.45 " temp. 69° — 9.2 sec. — 9.2
 " " 28, 2 " " 95° — 19. " — 9.8 — 0.6 sec.

At this I allowed it to pass.

Now, this example and the previous one in isochronism and position adjustment furnishes a sample of a record to be kept. But this record may be interspersed, not only with the notation of changes, but with any notes, remarks or reflections that may be cogent to the work in hand, or that may embody and preserve the experience we have gained. In that way we can make it not only interesting but exceedingly valuable in an educational sense. I have, in this way, kept the records of hundreds of watches that have passed through my hands, the history of all of which I can retrace by referring to them. Nay, during a period of ten years in factories, thousands of watches have passed through my hands for adjustment to temperature, the records of all of which I have kept in the above way and can be referred to.

22. Adjustment Between the Horizontal Positions.—Hitherto, I have not dwelt, except incidentally, on the adjustment of the rate between the two horizontal positions, "dial up" and "dial down;" and this for the reason that it should be the last in the orderly proceeding of the work—the finishing touches, so to speak. In the alterations that we make in temperature adjustment, in trials for isochronism, and particularly for the agreement of the mean rate between the vertical and horizontal positions by the regulator pins, the discrepancy in the rate between "dial up" and "dial down" may suffer

modifications, possibly even complete annulment. The variations of rate between the two horizontal positions usually, not always, arise from differences in the arcs of motion of the balance, the spring being seldom perfectly isochronal. Now, we have seen that we can harmonize the rate between vertical and horizontal positions by opening the regulator pins if the watch goes fast in vertical positions, and by closing them if it goes slow in the same positions. This, supposing that the inequality in the rate between "dial up" and "dial down" arises from differences in the arcs, would also make a change in the relative rate of the latter, possibly for the better. It would, therefore, be manifestly unwise to attempt corrections in this respect before all the other adjustments are satisfactory. Furthermore, if there is any notable difference in the rate between dial up and dial down, we want to know in which of the two positions the correction should be made. This we cannot tell until we have the final and satisfactory agreement of the rate between the three principal vertical positions. The two most important positions—those in which the rate of the watch should more nearly agree than in any others—are the positions "dial up" and "pendant up," for the reason that these are the positions in which watches ordinarily run when in use. A difference of two, three, or even four seconds between "dial up" and "dial down" is immaterial, if the rate in the former two agrees. If, however, it should be found upon a final trial for position error that the rate "dial down" more nearly agrees with that in vertical positions, and there should be that difference between "dial up" and "dial down," it must be corrected, and the corrections applied to "dial up."

Inequalities in the arcs of motion, and therefore in the rate between dial up and dial down arise mainly from two sources of disturbances—viz.: defective pinning in of the balance spring, and difference in the friction at the balance pivots. If in pinning in the spring has been dressed up or down, and its lamina twisted in order to level it, there will be a worming up and down, so to speak, of the spring, analogous to that of a corkscrew, which tends to lift the balance from one endstone and press it harder upon the other. The remedy for this is the straightening and the re-

pinning of the spring. It may be necessary to cut off the twisted portion and repin it. On the supposition that the inequality of the rate in the horizontal positions arises from difference in friction at the pivots, we may correct it by altering them—*i. e.*, by making one or the other a little flatter, or a little more rounding, as the case may require, in order to diminish or to increase the arcs of motion in the particular position, according as the known anisochronism of the spring dictates. As a rule, the motive power remaining the same, increased friction at the pivot will diminish the extent of the arcs of motion, and decreasing it will make them greater. We must, therefore, know, first, which of the pivots requires treatment, and, second, what the final anisochronism of the spring is, ere we attempt the correction.

Supposing, for instance, that the agreement of the rate between "dial up" and "pendant up" is satisfactory and there is a discrepancy in the rate "dial down" which we desire to correct; supposing, moreover, that the rate in that position is slower than in the position "dial up," and that the anisochronism of the spring is such that the short arcs are performed a little faster than the long ones; by flattening the lower pivot—which is the pivot the balance runs on in the position "dial down"—and thereby creating more friction and reducing the extent of the arcs of motion, we accelerate the rate in that position; and, if the contrary effect were required, by rounding it and thereby diminishing the friction and increasing the arcs, we make it go slower.

On general principles the rate of a watch in horizontal position varies with the arcs of motion of the balance. There are, however, times when a difference in the latter does not seem to affect the rate. This is the case when the anisochronism in the spring is very slight, and then discrepancies in the rate between "dial up" and "dial down" must be attributed to other causes. As a rule, however, the agreement of the rate in these positions in such a case is close enough.

As has already been repeatedly intimated in these pages, we cannot hope for a very close isochronism of the balance spring in watches, not that it could not be accomplished, were watches, like ship chronometers, running in one and the same position constantly, but it would not

be the best condition under actual circumstances. A very slight anisochronism, however, is often, and would always, be sufficient to harmonize position adjustment were there no mechanical defects in the watches that elude our vigilance, and were position error due to "proper motion" of the spring or the oscillation of its center of gravity, the only disturbing factor we have to combat.

We have seen, too, in our study of the laws governing the isochronism of the spring (5 Pl. I. & III.) that the rate of a watch for different arcs of motion, when graphically represented, does not produce a straight line nor one uniformly inclined to a straight line, but a more or less irregular curve, depending upon the angular distance of terminal pinning. A change, therefore, affecting a wide extent of arc such as generally exists between vertical and horizontal positions may come under the influence of a slight anisochronism, when small differences, such as we can produce in the horizontal positions, will not be affected thereby. All these conditions, and many others that we may be ignorant of, influence our results, and they must be taken into account in any attempt to intelligently and rationally adjust watches. It is no exaggeration to say that the adjustment of watches is one of the most complicated problems in the whole range of mechanical science, requiring an amount of knowledge and experience that can be acquired only in a lifetime of diligent study, even now, when we have the help of so many able mathematicians who have given us the result of untiring research.

I may supplement the above remarks by cautioning the workman against a too hasty adverse judgment or loss of courage, should the result in position adjustment, after he has done the best, be unsatisfactory. Permit me to reiterate that watches must be well conditioned and mechanically in good order in other respects than what pertains to the adjustment proper of the balance spring, if our work is to be a success. They should have a good motion. As previously stated in this work, the motion of the balance should not fall below 360° in the horizontal positions during the interval between two successive windings, and it should be uniform and regular, not intermittent. It is a sure sign that in some way the me-

chanical condition of the watch is defective if the motion of the balance is variable. I may repeat the statement I made elsewhere, the truth of which is corroborated by a long experience, that when a watch is in good order and we have made correct inside and outside terminals to the balance spring, its position error will fall within the limits of five seconds in 24 hours. If it does not do that we may be sure that the cause for it is chargeable to some other part of the mechanism of the watch. For illustration, I may cite, from among many, an example of recent experience: I was requested to repair and adjust a once fine Paul Henri Mathey watch, with long fork. I mention this latter feature because it is assumed by many that we cannot do as well with long forks as with short ones. After some minor repairs to the train and the putting in of a new balance arbor the watch seemed to me to be in good order, and I proceeded with the adjustment of it by putting in a new balance spring, making correct inside and outside terminals. I always do the best I know how, taking all the time necessary for the accomplishment of what I set out to do, and I thought that I had succeeded particularly well in this instance. The result, however, of the first trial for position error was far from being satisfactory. The following is a copy of its record, omitting all but the rate in the different positions:

Dial up	+ 0.5 secs.
“ down	+ 1. “
Pendant up	+ 21.6 “
“ to right	+ 27.8 “
“ to left	+ 3. “

Here was a difference of more than 24 seconds between “pendant to right” and “pendant to left,” a second an hour, and between vertical and horizontal positions even more than that. I knew from experience that this result was not due to any want of adjustment of the spring. I observed that the motion of the balance was not what it ought to be, that it was, moreover, variable, and I proceeded to search for the cause in the train and soon found it. I found that someone had replaced the center pinion, which was jeweled, top and bottom; that the upper pivot was too small, while the lower one, running in a thick jewel, was fitted too snugly and would bind in the

hole when the pressure of the spring was applied, the pinion, by reason of the small upper pivot, being thrown out of upright. I furthermore discovered that the lower barrel hole had been bushed and was also out of upright, which, together with various other defects about the barrel, conspired to make matters worse. I made a new center pinion and eventually a new barrel, uprighted it and passed it, together with the rest of the wheels, through the Ingold fraise. I did nothing else to the watch, never altered or touched the balance spring nor any part of the escapement. When the watch was running again, and at the very first trial, the result was as follows as to rate in positions:

Dial up	—8. secs.
“ down	—9. “
Pendant up	—5. “
“ to right	—5. “
“ to left	—7.2 “

This, with many similar experiences, proves the statement I have made that when a watch is in good order the result of our work in adjusting will be satisfactory. It may take us more time and cost more work than we had anticipated, and watches that have been tinkered generally do, but a little patience will conquer all difficulties.

23. Standard of Excellency of the Performance of Watches. Nothing can be less reliable nor more fictitious than the statement we often hear concerning the close running of watches; that such and such watch, for instance, has not varied a second in—, a very long time; nor is the fact that a watch, after an interval of longer or shorter duration when no specific conditions are stated, differs but little from correct time any criterion of the excellency of its performance, for during that interval it may have varied backward and forward many times by more than the quantity it is found wanting at the end of the time. The only correct test is a systematic observation of its performance under known conditions. If it satisfies such test, it may be assumed that, barring accident, it will satisfy the requirements of its owner or wearer. In the Geneva and Neuchatel observatories (Switzerland) watches are subjected to a test lasting forty

days, in eight periods of five days each, during which they run in different positions and temperatures, etc. The standard of excellency adopted at the Geneva observatory since 1891 is the following:

A watch is considered entitled to a first-class certificate—

1. When the mean daily variation for the same position and temperature does not exceed 0.75 sec.
2. When the mean variation from the mean rate in the five positions does not exceed. . . 2.5 “
3. When the variation of rate from change of temperature, per degree centigrade, does not exceed. 0.2 “
4. When, after it has been subjected to a change of temperature, the resumption of its rate in ordinary temperature does not differ from its initial rate by more than. 5. “

With this standard of excellency before him, which, by the way, is now easily beaten by many of the adjusters abroad, the workman will have a means of comparing his own work as well as of testing the claims of that of others, particularly of those “fully adjusted” watches referred to before.

24. On the Use of the Plus and Minus Signs in Rating Watches.—I have stated in the foregoing pages that I was using the plus and minus signs in the sense that the sign + characterizes the loss, and the sign — the gain in the rate of watches. As this is exactly contrary to the sense in which watchmakers generally use them, when they use them at all, or as most mathematicians use them when dealing with the rate of watches, I desire to make an explanation stating my reasons for so using them.

It will be sufficient explanation for those familiar with applied mathematics, particularly as touching problems in astronomy as well as navigation, in which time is an element, to state that I treat the quantity by which the rate of a watch or chronometer differs from mean time rate, as the correction to its rate. They will immediately admit that I am perfectly correct in using the signs as I do, and this in spite of the fact that they them-

selves may use them in the contrary sense when dealing with the rate of chronometers and watches. The fact is, it matters not in which sense we use them, so far as the work of the watchmaker in regulating watches, or that of the mathematician in calculating the effect of various factors upon their rate, is concerned, provided, however, that when we come to the practical application of them in the determination of correct time, we interpret them correctly.

Let me begin by stating that what we commonly term the rate of a watch or chronometer is not the rate at all, but the amount by which the rate lacks or exceeds the standard rate. We speak of the rate of speed of a railway train as so many miles per hour, or of the rate of speed of a wheel as so many revolutions to the minute, etc. In like manner the rate of a watch is some number of vibrations of the balance, which we convert into time divisions as seconds, for instance, in a given time. The standard rate of time is dictated by the revolutions of our planet around its axis. This is, in even numbers, 24 hours, which is again divided into 86,400 seconds. This is the standard rate of time measuring instruments, that being the cycle of time for which the rate is usually given. If a watch or chronometer registers less than that number of seconds in 24 hours it is said to be losing, i. e., its rate is slower, and if it registers more than that number of seconds it is said to be gaining, i. e., its rate is faster than the standard rate.

In the light of this definition let us ask what is the meaning of the terms "slow" and "fast" applied to the rate of a watch? Plainly this, that when I say, for instance, my watch goes five seconds slow, I mean that I must *add* five seconds to its rate every day to make it come up to the standard, and when it goes five seconds fast, that I must *subtract* five seconds from its rate for the like purpose. Now, the signs + and - have but one meaning, which may be found stated in every elementary algebra published in the world, and that is that the sign + indicates that the quantity before which it stands must be added, and the sign - that the quantity before which it stands must be subtracted. If, therefore, I want to use these signs for the purpose of conveying the above meaning of the words slow and fast, or indicate the operation

to be performed in reducing the rate of my watch to the standard, I must prefix the sign + to the quantity by which it goes slow, and the sign — to that by which it goes fast.

But it may be said that the quantity by which a watch or chronometer gains may also be considered as an addition to the rate it ought to have—namely, standard rate; and that by which it loses as a diminution; and that, therefore, in this case, we must prefix the sign + to the gain and the sign — to the loss. According to this definition, if my watch is five seconds fast, I would have to state it in the following terms: My watch indicates correct time + five seconds, and when it is five seconds slow, that it indicates correct time — five seconds. We may do that and commit no error for the mere purpose of keeping an account of its performances. Let it be borne in mind, however, that the legitimate use of watch or chronometer is as a means to ascertain correct time. We always know the time it indicates by inspection. In the determination of longitude by the mariner at sea, in the observation of the passage of heavenly bodies across the meridian by the astronomer, in civil life—in fact, in all practical uses of a time measuring instrument, the function demanded of it is the fixing of the true time of the moment. It may do that whether we use the + and — signs as I use them; or, as they are commonly used, in the contrary sense; only, in the latter case, we have to change the signs when applying the quantity before which they stand; in the former, not. The watchmaker who has rated the chronometer of a vessel, in handing it to the shipmaster, delivers it with a slip, on which is recorded its rate, and tells him—or if he does not tell him, the shipmaster knows it—that when he wants to make use of the rate he must change the sign by which it is prefixed. The astronomer, wishing to determine the true movement of an observed phenomenon, must add the rate of his clock to the time it indicates when the latter is slow, and subtract it when it is fast; and, if he has used the plus and minus signs as they are used by the watchmakers, he must change them, and so on throughout all the operations, scientific or practical, which depend upon the ascertaining of correct time. Why not use the signs properly and logically, as I have used them,

in the first place? Astronomers, mariners and mathematicians all know that it is the right way; but custom has sanctioned the habit of the common use by the watchmaker, and, as it is a matter of no importance, entailing no risk of error on the part of the mathematicians, it is allowed to pass unchallenged, as being the shortest way out of a dilemma. I can think of no other explanation.

In a work intended for the use of the watchmaker, it was at first a question with me whether I had not better use the signs as they are commonly used. I could not use them as I am accustomed to without constant explanation, and I feared to provoke unfavorable criticism by so doing. I found, however, that, in the end, I could not discipline my mind to abjure a conviction of right. Besides, having always used the signs in that way, I feared that I might commit errors in changing them, and so concluded to maintain my accustomed way of using them, always, however, reminding the reader of the sense in which he is to read them.

I would say, too, that I am not alone in using the signs in the sense I do in connection with the rating of watches. In the reports of the director of the observatory at Neuchatel, Switzerland, Dr. Ad. Hirsh, on the competitive trials of watches, they are so used, and, for aught I know to the contrary, elsewhere and by others, too.

CHAPTER V.

HOW TO MAKE A BALANCE ARBOR WITH MODERN APPLIANCES.

I HAVE, in the foregoing treatise, spoken of mechanical conditions in watches that are essential to good performance; among other things, I have alluded to the proper form of the pivots of the balance arbor. But the great importance of the part the latter play in the adjustment of a watch seems to call for a more extended treatment; the more so, as it is very seldom that we find these approximately perfect, even in fine watches. To supplement, therefore, what I have already said on this head, I will describe the method of making a mechanically perfect balance arbor.

Whoever has seen the making of steel rolls for paper mills and reflected upon the accuracy required of so gross a machine, will be surprised, or ought to be surprised, at the clumsy method watchmakers employ for making the infinitely more delicate and accuracy-requiring arbor which is to support the balance of a watch in its function of measuring infinitesimal quantities in the flight of time; for here, too, perhaps more pointedly than in any other sphere of human action, might the common experience be supposed to find application—viz.: that an apparently insignificant cause may produce great differences in the result wished for. This is particularly true as to the effect of badly made pivots on the rate in vertical positions.

I should perhaps ask pardon of the reader for making the very dogmatical statement that no man, be he ever so skillful, can make a good pivot with a polishing slip in the free hand, in the lathe; but I, nevertheless, mean all that these words in their fullest sense imply. It would be useless to discuss, and I do not care to waste words in showing the reasons why not—the less so, as we have the mechanical means at our service, the so-called “pivot-polisher,” to make not only the pivots, but the whole arbor perfect and true. The process which I shall describe is therefore that by means of this latter attachment.

The illustration here given, Fig. 1, one-half natural size, is that of the latest and most approved construc-

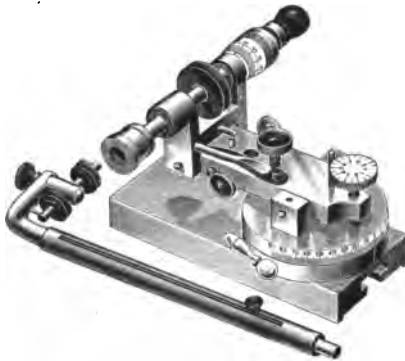

FIG. 1.

tion. The attachment is so generally known that to add a description is scarcely necessary. It will be seen that it is fitted onto the shoe of the lathe, and that the frame carrying the spindle revolves about a swivel indexed to degrees of the circle. This makes it capable of being set horizontally at any angle to the work. The horizontal part of the frame is pivoted centrally over the swivel and controlled by a set-screw on either side of the center, enabling us to raise or lower the spindle and fix it at any height to the work. The vertical part of the frame, that in which the spindle runs, is also pivoted to the horizontal part, allowing for a forward and backward motion. A finger pad extending out from

the frame enables us to communicate that motion to it, while a pin and set-screw supply the means of limiting it to any extent. The spindle has a horizontal traverse motion in its bearings, and at the rear end of the frame is a thimble, through which it passes, with a micrometer screw, and index reading to hundredths of millimeters, which acts as a stop to its motion. The extension wire alongside of the illustration is an idler, with a pair of pulleys to be mounted upright in the frame, for belting the spindle from the countershaft. Fig. 2 is a half-tone,

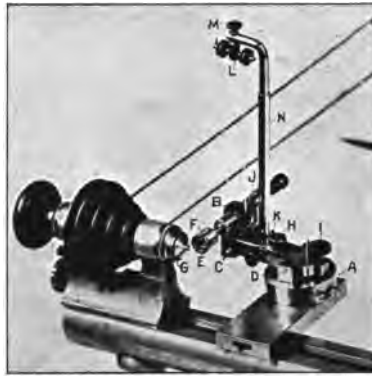

FIG. 2.

showing the whole attachment in position on the lathe, with the spindle at right angles to the spindle of the lathe, ready for polishing a conical pivot. A moment's inspection of the attachment itself will explain the manner of using it better than the minutest description.



FIG. 3.



FIG. 4.



FIG. 5.

Figs. 3, 4 and 5 are laps used in pivoting; Fig. 3 for polishing undercuts; Fig. 4 for slight back tapers, and Fig. 5 for cylindrical work and facing. Of Fig. 3, one

in brass or soft bell metal, is all that is needed; but of Figs. 4 and 5 the workman requires duplicates in steel, brass and block tin, the latter being used only to give a final slight touch and producing a very high polish. This is never necessary in making pivots. Fig. 6 is a



FIG. 6.

chuck with taper end, of the same size as the taper of the lap spindle, which is used for turning up laps and redressing them when necessary. Figs 7, 8 and 9 are, respectively, diamond, block tin and emery laps, very useful for purposes other than pivoting; for the at-



FIG. 7.



FIG. 8.

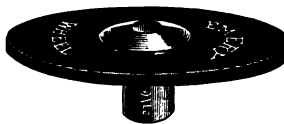

FIG. 9.

tachment is useful in an unlimited number of cases and kinds of work, the description of which does not pertain to the subject in hand.

The use of these accessories being understood, we may proceed with the description of making the arbor. But first let me say to the reader that it is absolutely essential he should possess a set of chucks for his lathe, sufficiently numerous, at least in the smaller sizes, to admit of small

differences in the sizes of holes, say, not over 0.05 of a millimeter between succeeding numbers up to 2.0 millimeters in diameter of hole. As manufacturers list them, this would include every half number from No. 3, which is the smallest, up to No. 20. And the chucks must be ground absolutely true to their sizes and true to the center of the lathe spindle. It used to be almost impossible to get a true split chuck from any of the makers, but the mechanical improvements introduced of late years in the manufacture of them enables us now, on requisition at least, to get them absolutely true. I speak of this because with a set of chucks that are true the cementing of work is entirely obviated. Not only that, but we are enabled to take the work out of the lathe for examination and put it back again without in the least getting it out of true. The workman who is not the possessor of such a set of chucks will have to cement his work.

Another essential is good measuring instruments. We must have a linear measure capable of reading to 0.1 of a millimeter or less. The well known Boley gauge reading to 0.1 and capable, with a little practice, of reading to 0.01 of a millimeter, is well adapted for all purposes, the better so as it reads both ways, between callipers and from the end of the foot. For small objects and diametral measurements the Grossman round micrometer is the best known, reading to 0.01 of a millimeter.

Having these instruments at our service, we next proceed to establish the dimensions of every part of the balance arbor to be made. If we are in possession of the old arbor, and its dimensions are found to be correct, we can get them from it; if not, we have to obtain its dimensions from the distance of the upper and lower endstones, allowing for endshake, and the height at which the balance and impulse table are required to be in relation to the other parts of the escapement. The following are the dimensions required, using a practical example for illustration and measuring from the end of the lower pivot upward:

Total length of the arbor.....	6.2	mm.
“ “ to seat of balance.....	3.45	“
“ “ above seat of balance.....	2.75	“
“ “ to seat of impulse table.....	2.7	“

Total length of core between balance and table	0.75 mm
Thickness of balance arm.....	0.35 mm.
Allowance for riveting.....	0.1 "
Length of balance axis.....	0.45 "
" " collet axis.....	0.85 "
Diameter of core.....	2. "
" " balance hole.....	1.25 "
" " collet hole.....	0.9 "
" " table staff.....	0.6 "
" " pivots.....	0.11 "

FIG. 10.

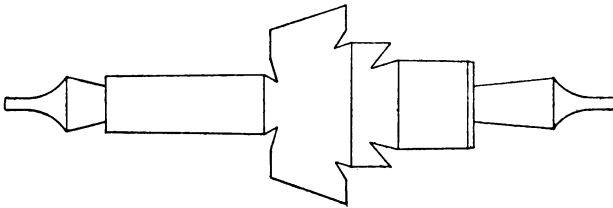
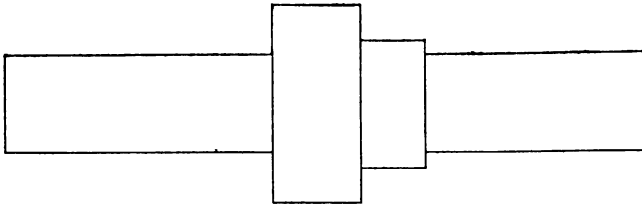

FIG. 11.

The dimensions thus ascertained should be put down on the bench paper in convenient sight.

The next step is the preparation of the blank, which I invariably make myself, as those we find in material stores are generally the merest trash, poorly tempered and badly turned up. I select a piece of steel wire a trifle thicker than the diameter of the core between balance and table. With a sharp slide rest tool I turn it down to full size for the whole length. Then I turn it down in thickness from the end to within 0.05 of a millimeter of the

actual measure of the balance axis, and for a length of about 0.2 of a millimeter more than the length of the arbor above the seat of the balance when finished, using for measure the foot end of the Boley gauge. By a second cut I turn down the end to some size of wire chuck, say No. 10, the hole of which measures just one millimeter in diameter, or even to a smaller size like No. 9—but it must fit it exactly and be cylindrical—leaving about 0.2 of a millimeter more of the first cut than the finished length of the balance axis. I then cut it off at a sufficient length to include the total length of the arbor, turn it in the lathe, taking it now into the chuck to which the upper end was fitted, and I turn down the lower portion to the same size in thickness as the upper one, leaving enough, say 0.1 of a millimeter, more of the length of the core between balance and table than required when finished and about as much longer in the lower staff than the finished arbor. Instead of turning the blank in the lathe, the workman may, with a properly shaped tool, turn down the lower end of it to required size before cutting it off. This can best be done with a cutting off tool beveled towards the chuck so as to present a sharp point to the work instead of a square flat one, as is usual in cutting off tools. Then, taking a cut toward the center of the work immediately back of the core, continue the cut longitudinally towards the end of the lower staff, and repeat that until the proper diameter is obtained; and then cut it off. Figs. 10 and 11 illustrate respectively such a blank and the finished arbor enlarged from the above dimensions. The core in Fig. 11 is drawn so as to show all the undercuts necessary.

I may be permitted here to indulge in a digression on the use of the slide rest. I see so many watchmakers who disdain the use of that attachment, allowing it to rust away in their bench drawers. They seem to be afflicted with the belief that it is not only dispensable, but that the use of it would needlessly consume a great deal of time for which they would never get any pay. There is a degree of truth in the latter charge; we, unfortunately, get too little credit for doing good work. But, this being the case, if we have no other incentive to effort, bench work must soon become a loathsome drudg-

ery, and this is the case with many workmen with whom I have come in contact; they work like slaves—because they have to. I am very sure that this is one of the reasons why the quality of workmen is so low, in this country especially, and why we see so many “butchered” watches. To be sure we have made watches for centuries without the slide rest, and, to our shame perhaps, we may admit that better work was done then than we are doing now, at least as to its artistic features. But that is no argument against the use of improved machinery, and the slide rest is certainly an improvement over the hand tool where accuracy and expedition are essential. Besides, to him who can appreciate good work and loves to do it, the use of good tools is an unspeakable pleasure. And let it be borne in mind that the pleasurable condition of work is an indispensable condition to good work. The man who has no pleasure in his work will not do good work even when he is well paid. Pleasure in the work comes principally from the use of good tools and proper methods. What matters it if we fail to get credit from the mass for what we do well? That, for most of us, is only ephemeral. What we want most is that the present should be pleasurable. There are a few who are able to appreciate good work, and they will not fail to recognize merit where it is found. We must be satisfied with the good opinion of such. But to return; the slide rest is one of the most valuable adjuncts to a watchmaker’s lathe. Go into a machine shop and tell us how much of the work done there could be done without it. There are those who think that the work a watchmaker is called upon to do is too small for the use of the slide rest. That is a great mistake. I turn the smallest and most delicate pinion with the slide rest, pivots and all. As a matter of fact, I never turn a pinion of any kind with the hand tool. The fact that a pinion is tempered steel is no obstacle to our turning it with the slide rest tool. What we can turn by hand we can in most cases turn with the slide rest tool if the latter is properly made. Again it is claimed that it takes longer to do the work with the slide rest than with the hand tool. That depends upon how we go about it. If your slide rest screws are indexed you can work to given measures with more certainty than with the hand tool and quicker; and where you have more than one

piece of a given kind to make the slide rest will doubly discount the hand tool. As for accuracy of the work done, there is no comparison. I will take a chip from any metal but hardened steel or bell metal that shall not measure more than half a hundredth of a millimeter in thickness, a chip which some of us cannot see with the unaided eye, but which yet exists in unbroken length. As to rapidity: if we apply oil to the cutting edges of the tool, the same as they do in the machine shops, we can readily take a cut of half a millimeter, or even a whole millimeter, in thickness, with the greatest ease. Thus, to return to my subject, I rough out my blanks for balance arbors with the slide rest tool myself. The next step is the hardening and tempering of it.

To do this properly, in the case of a single piece, under an alcohol flame, a blow-pipe with a rather large orifice should be used in order to blow a well-spread, gentle flame, the blank being laid on an asbestos pad. This should be done in a dark place, so as to be able to see well the proper degree of heat to which it is brought. It should be heated to a light cherry red and then dropped into cold water. If the light is too bright one is apt to overheat it and burn the steel. The workman may to advantage turn up a number of blanks at leisure, differing somewhat in dimensions, so as to have an assortment on hand to select from, and harden them all at once in the following manner: A piece of gas pipe $3\frac{1}{2}$ centimeters long, closed at one end, may be mounted on a piece of wire, upright into a solid base, at a convenient height from the bench. A Bunsen burner supplied with air from a foot-bellows may be placed so as to blow a strong blaze at this mounted tube. Into this tube lay all the blanks you wish to harden, blowing the flame at the outside of the tube. When all the pieces are heated to a cherry red, which we can see through the open end of the tube, hold a glass of water in front of it—the tube being horizontal—and with a gentle tap on the wire from the rear, throw all the pieces into the water. They will be found properly and equally hardened. The most delicate pieces of wire may be hardened by this method almost without warping them.

The blank must now be made white in order to blue it. For this purpose, it is taken into the lathe and cleaned

by holding against it a flattened piece of pegwood charged with carborundum powder mixed in oil. When both ends of the blank are thus cleaned, throw it into gasoline and wipe dry with a rag. Care must be taken not to let any of the carborundum get into the chuck. Now draw the temper of it to a dark blue, slightly merging into violet, and the blank is ready for turning.

It is useless to make a balance arbor so hard that it can only be turned with difficulty. It will not wear any longer, and if it should ever need pivoting, the operation is next to impossible without drawing the temper. It must be expected that a balance arbor, for satisfactory service, would require renewing every six to seven years. When all the conditions are the most favorable, it may last ten years; but with the thin jewels that are generally found in fine watches it is scarcely possible. I know workmen who are in the habit of polishing balance pivots every time they clean a watch, or at least whenever they show the least wear. This is bad practice. The watch will not go any better for that reason; on the contrary, it may go much worse, for every time the pivots are repolished they are not only diminished in size, which of itself is detrimental, but the shape of them is altered. When pivots are cut badly enough to interfere with the time-keeping of the watch, the proper remedy is a new balance arbor.

We now proceed to finish the arbor. It will be found that when hardened and tempered in the before described way, the blank has scarcely warped; often not at all. I invariably finish the upper part first. Taking the lower staff into the chuck to whose size hole it has been turned, I true up, if necessary, now with the hand tool, the portion intended for the balance axis as well as the seat for the balance, and I am careful to undercut the corner of the seat, as shown in Fig. 11. This is done with a sharp lozenge graver. Next I grind it to fit the hole of the balance. This is done with a steel lap of the form of Fig. 5, using as abrasive medium fine carborundum powder mixed with oil. First, however, the lap must be put into proper shape and order. It will be observed that the stock of the middle portion in the cylindrical surface of the lap has been removed, leaving at both ends a raised ring. This is done in order to enable us to file

it flat longitudinally over its circumference, holding the lap between two fingers, and using a file of medium fine cut, turning the lap slowly between the fingers while filing, using but very slight pressure on the file. When the circumference is thus filed evenly, a stroke or two is given on the flat face of the lap, turning it between each stroke in order to cross the lines. This filing will give a degree of roughness to the surface of the lap sufficient to hold the abrasive medium, and serves to keep the front working corner sharp. It has to be repeated quite frequently after using it.

The pivot polishing attachment is now put in place on the lathe bed with the index of the swivel set so as to give half a degree taper to the axis we wish to grind. To accomplish this it is essential that the center of the lap should be at the same height from the bed of the lathe as the center of the lathe spindle. This is easily done by means of a male center inserted into the spindle of the pivot polisher, with which it is provided. We next put a trifle of carborundum powder on to the lap, feed it up to the work gently by means of the feed screw until it touches, and grind while moving the spindle backwards and forwards in its bearings, with the lathe in rapid motion, allowing the lap to touch both the cylindrical portion of the axis and the seat for the balance in the course of its backward and forward motion. The grinding spindle must be belted, so that the motion communicated to it is in the same direction as the motion of the lathe spindle. That being the case, the circumferences will, when running alongside each other, run in contrary direction at the touching point. This grinding is kept up until the balance fits onto the axis in such a way that when pushed down onto the seat it is moderately tight. Of course, some experience is necessary to do this, as it is for everything that is to be done right, no matter how perfect our means may be. The feeding must not be too rapid, otherwise it will spoil both the lap and the work. It will be found that it works rapidly enough, and if the blank has been turned down to very nearly the proper size, the work is done in a moment, and perfectly true. It is essential that the front corner of the lap should remain sharp; for this reason the undercutting of the balance seat must be done

before commencing the grinding process. In this way the seat for the balance will become dead true to the cylindrical portion of the axis.

We next turn down for the collet axis to within 0.03 of a millimeter of its finished size, at the same time reducing the length of the balance axis to within 0.05 of a millimeter of the finished length, and undercut it deeply for the purpose of riveting the balance to it, as shown in Fig. 11. The collet axis should be turned slightly tapering, the same as the balance axis, and we may step off its length a trifle longer than the finished measure requires. The rest of the upper staff may be turned down to a size corresponding with the lower one, at all events not smaller than 0.5 of a millimeter, and cylindrical. We now mount the pivot polisher again on the lathe and grind the collet axis down to size, as we did the balance axis, and to the same taper, taking care not to grind the length of the balance axis with the front face of the lap beyond its required length when finished. The Grossman round micrometer is convenient for measuring the thickness while the work is in the lathe. Before commencing to grind for the collet it may be well to take off the lap and refinish its grinding surface by filing it as before explained. We should always use a somewhat narrow and new file for this purpose.

When the axis for the collet is thus ground we proceed to finish the rest of the upper staff. For this purpose we now set the index of the swivel, on which the frame of the polisher is mounted, to 0°, so as to grind cylindrically. We may give it a first smoothing with the steel lap and carborundum powder, but if we have turned it smooth with the graver we can proceed immediately with the bell metal lap and diamantine, which will be found to work very rapidly and polish beautifully. Precaution must be taken to undercut a trifle the corner produced by the meeting of the cylindrical side of the staff and the face of the collet axis, in order not to abraid the sharp corner of the lap. Then use the polishing lap just long enough for this undercut to disappear, when the now polished side of the staff and the top face of the axis for the collet will meet in an invisible corner. Both will be found beautifully polished, flat and true. To clean the work of the oil and polishing material for examination,

dip a piece of soft pith into gasoline and hold it against the staff, which will immediately take up all the dirt. Finish cleaning with the dry end of the pith. Instead of making the upper staff cylindrical and then undercutting back of the pivot, we may give it a back taper, as illustrated in Fig. 11. In this case, however, we must use polishing lap No. 4, to finish it.

We may now commence the upper pivot and reduce the upper staff to its finished length. To turn a conical pivot we must use a graver with a slightly rounded point. The T rest is set close to the work, and we turn the cone

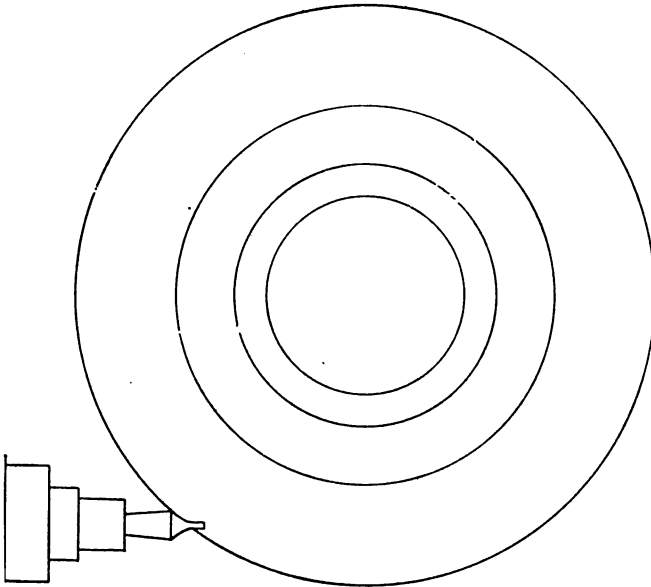

FIG. 12.

by moving the graver from the end of the staff toward the cone. We turn the cone into length and form as we want it, and the straight part of the pivot to within 0.1 of a millimeter of its finished diameter, and then we reduce the upper staff to its finished length, measuring from the seat of the balance up. This is done with a smooth Arkansas oil stone slip, applying it as flat as we can guide

it by hand and sight. We then finish the turning of the pivot and conical shoulder with the round pointed graver to its proper length and shape (see below), stopping when the diameter of the cylindrical part of the pivot is within 0.03 to 0.04 of a millimeter of the finished measure. It may now be polished with the lap and diamantine. For this purpose the spindle of the pivot polisher is set at right angles to the lathe spindle. Its center must be raised above the center of the lathe spindle, so that the circular corner of the lap will fit into the shape of the conical shoulder of the pivot, while the flat face, extending down below the center of the pivot, will polish the straight cylindrical portion of it, as shown in Fig. 12. The exact height at which the center of the lap ought to be above the center of the pivot is optional within narrow limits, depending somewhat on the diameter of the lap used. With a lap ten millimeters in diameter a good cone is obtained by placing the center of it about eight-tenths of the radius of the lap above the center of the pivot. This is the case in Fig. 12. It may require a little reflection on the part of some of my readers, who may never have seen the process, to perceive that that will do it, but an experiment will soon convince them that it does, and beautifully. Of course great care is necessary, and experience soon educates us up to what is required in that direction. It is not necessary to use the steel lap and carborundum first on pivots, the diamantine and bell metal lap works fast enough. It is necessary to exercise extreme vigilance lest our pivot is reduced too suddenly below the size required. In all cases of lap work the speed of the part to be ground should be considerably slower than that of the lap, and in polishing conical pivots it is well to reverse the motion occasionally during the process, as this will distribute the polishing medium better on the lap and the surface operated upon. Only a small quantity of the latter is required, which may be applied to the lap with a small spatula while the work is going on. A very slight pressure on the back of the lap spindle is necessary, which we may exert with the left hand, while the index finger of the right hand may operate the pad, giving the lap a very slight backward and forward motion longitudinally to the pivot. We may set the thimble on the rear of the spindle frame to form a stop, which will pre-

vent our making the pivot too small suddenly, but a short experience will make this unnecessary. If the circular corner of the lap becomes rounded it must be taken off the spindle and refaced with the file across the face of the lap. The lap used for conical pivots need not be faced over its circumference, as that part never comes in contact with the pivot or the cone.

I have said that for polishing conical pivots the lap spindle should be set at right angles to the spindle of the lathe. I deviate a trifle from this by setting it about one-quarter to half a degree taper toward the end of the pivot, and for the following reasons: In filing up the face of the lap a good many times the latter unavoidably loses a trifle its perfect flatness, some portion of it will be a trifle higher than others; *i. e.*, it will stand slightly inclined to a plane passing at right angles to and through the center of the spindle. This may be so slight that it is unnoticeable when the lap is in motion, and yet, if the spindle stood exactly at right angles to the lathe spindle it would produce a pivot slightly conical in the reverse direction—*i. e.*, make it smaller near the cone. To avoid this, the above precaution is adopted; and, if it should make the pivot slightly tapering towards the end, it will be invisible, and do no harm. When the pivot is polished down to its proper size, we may face the end of it with a stick of block tin, using a little diamantine. It should be made slightly rounding, as illustrated in Fig. 11, and care must be taken to smooth the sharp corner. For rounding and polishing the ends of pivots I use a pair of small jasper slips, cemented on a piece of brass wire, the sides of which are ground flat and of different smoothness, which answer the purpose of polishing sticks admirably without the use of any polishing medium. The pivot being now finished, the only thing remaining to be done is the undercutting back of it, as shown in Fig. 11, on the lower staff. It should be observed that this is not done for mere ornament's sake, as, indeed, it frequently appears to be intended, but for the purpose of preventing the oil from creeping up onto the larger parts of the arbor, and for that reason it should be made wider and deeper than we generally find it. Instead of this undercut, the whole of the upper staff is sometimes made

tapering in the same direction. When this is done, the form of lap illustrated under Fig. 4, or even that of Fig. 3, may be used for polishing it.

When the arbor from the balance seat up is finished, it is then reversed in the lathe. For this purpose, it can now be taken into a chuck by the collet axis. Care must be taken to select a size if possible that will just take in the top of the cone forming the axis; then push it in up to the seat of the collet. This will spread open the jaws of the chuck a trifle and make the hole tapering conformably to the taper of the axis, and it will be found to hold the arbor perfectly true. The lower part of the arbor is now finished and fitted to the impulse table. It should not be necessary to further describe this proceeding, as it is just the same as for the upper staff. A little experience will teach the workman more about the use of the laps than much description. I do, however, think it well to describe the method I follow for getting the different lengths of the arbor just right according to the measures established. Those who are acquainted with the Boley gauge may not need this; but for the sake of others who are not, I beg their indulgence.

The calliper slide of the Boley gauge has an extension on the side towards the end of the foot, which, when it is flush with the latter, makes the vernier stand at O on the index. Any projection of the end of the foot beyond the slide is directly readable on the vernier index. The starting point for all the measurements is the seat of the balance. That being established, and the axis for the balance finished, we measure the total length of the arbor from the seat of the balance up as it then stands. Taking the foregoing dimensions as an example: suppose that after finishing the axis for the balance the arbor from the balance seat up measures 2.95 mm.

Subtracting from this the length of the bal-	
ance axis45 "
Leaves	2.5 mm.

To this length I now set the foot of the Boley gauge and turn the rest above down to it, leaving the balance axis a trifle long. When the collet axis is turned down

and ground to size, and the undercut for riveting the balance is made, I subtract the length required for the collet axis thus:

Length to which the gauge is set.....	2.5 mm.
Length of collet axis.....	.85 "

Length left above..... 1.65 mm.

Again, I set the foot end of the gauge to this new measure, turning down the rest of the staff to it by holding the gauge up against the end until it corresponds to it, leaving the length of the collet axis a trifle full to allow for polishing its face. To get the exact length of the upper staff when the pivot is turned down, I set the gauge exactly to its length from the balance seat up and shorten it until it just spans it.

Having finished the upper staff, I now measure the total length of the arbor as it then stands.

Suppose it measures.....	6.4 mm.
Length of part finished.....	2.75 "

Length remaining unfinished.....	3.65 "
Length of core between balance and table....	.75 "

Length remaining below..... 2.9 mm.

This is the length I now set my Boley gauge to and turn the staff down to, and finish it by grinding it with the carborundum lap, to receive the impulse table. When that is done, I set the gauge to the measure of the lower staff to seat of table, and cut it off to it and finish the pivot. In this way I rarely fail to obtain exactly the length of arbor I started to make to the hundredth of a millimeter of the proposed measure.

It will be imagined by some that this method is tedious and slow. So it is for beginners; but it is the only method I have learned that will produce a perfect balance arbor, and when one has the necessary experience it is the fastest method. It is not supposed that so much pains will be taken with an arbor for a common watch; but when we wish to make one for a watch worthy of it, and that shall give the best results in the adjustment of it, no less degree of accuracy will satisfy the conditions. We need not take so much pains in polish-

ing parts that are not essential to good performance; a surface ground true with the carborundum lap is good enough for all parts except the pivots. Polish anywhere else is only a matter of luxury; indeed, for the balance and collet a plain ground surface is better, and I never polish these parts. But the pivots must be perfect. They must be perfectly true in the round, and cylindrical for a sufficient length; and the lap and spindle are, in my opinion, the only sure means of making them so.

What should be the proper length of pivots depends, of course, upon the thickness of the jewels. In a fine watch in which the jewels are generally thin, the cylindrical portion of the pivot should be fully three times the thickness of the jewel or more, but in one with thicker jewels that cannot be taken as a guide. The cone of the shoulder should not be too short, neither. With a short pivot and an abrupt cone, the oil is much more liable to creep up onto the cone than with a longer one and a more gradual cone.

A word may now be said, in closing, about the choice of metals for laps. For grinding with carborundum, steel is the only material; but for polishing I find that, except for the conical pivots, ordinary fine brass works very well, and is much more easily turned than bell metal. The latter metal, as a rule, is too hard; the polishing medium does not imbed itself so readily on its surface. It works slower and with much uncertainty, requiring greater watchfulness. Again, the soft brass is much easier to dress under the file, which is of frequent necessity. The only part on which I use a bell metal lap is the pivots. In this case only the front face of the lap ever needs dressing up, and the greater hardness of the metal prevents the rounding of the corner when running on the conical shoulder of the pivot.

These hints and instructions should, in my estimation, be sufficient to guide the willing workman in the attempt to make a good balance arbor. Every detail of experience cannot well be told. Some things the student must learn by his own observation. Generally, every one gets accustomed to certain ways of doing work, and when once the habit is formed it becomes second nature. This is right when the methods are correct. What we learn in that way we do with ease and with speed.

CHAPTER VI.

HOW TO CLEAN A WATCH PROPERLY.

A CLEAN watch, free of scratches or marks of any kind, coming from the hands of a watchmaker, is one of the criterions of a good workman. Of course, every watchmaker knows, or ought to know, how to clean a watch, and it may seem superfluous, if not arrogant, to tell them how to do it. The methods in vogue, however, differ greatly, and the question may arise, Which of them is the best?

It is only in the recent past that we were accustomed to see watchmakers behind show-windows—and the sight may still be had in some out-of-the-way country store—brushing away for dear life, at a movement, with a brush filled with chalk, cleaning it (?), the while he was looking out of the window in a vacant stare, or watching the passers-by, unmindful and unconscious of the fact that he was brushing off all the gilding or scratching off all the damaskeened surfaces of his customer's watch, not to mention the still more serious fact that he was depositing more dirt in the recesses of the plate and pinions than he could ever get out again. No watchmaker who cares anything for his reputation would claim now, at least not in public, that the chalk and brush method is a good one. All the improvements on this method, however, are not equally entitled to recommendation. The answer to the question, How can we

properly clean a watch, in the shortest possible time, without risking its deterioration in point of appearance must decide the method that is worthy of it.

I know this question will be answered variously by a multitude of workmen, not a few of whom will claim that their method is the best; but where there is a difference there always is a choice, and, counting myself, with due modesty, among this number, I think it well, considering the importance of the subject, to close my work with a description of my own. My method is that of washing the pieces in soap and water, at least the plates, bridges and wheels, rinsing them in alcohol and drying them in sawdust. To state it more in detail: On taking the watch apart I place all the pieces in a glass jar containing gasoline; thence they are taken and wiped on a clean rag. So far as all the steel parts are concerned, with the exception of brushing off afterwards any lint that may adhere to them, that is generally sufficient to make them clean. But the plates, bridges and wheels I afterwards dip in a solution of cyanide of potassium, to remove any tarnish, rinse them in cold water, wash them in hot water (if I can get it), rinse them again in clean, cold water, and lay them in a glass dish containing alcohol, whence they are thrown into a sieve containing fine boxwood sawdust and thoroughly dried. The only care to be taken with them afterwards is that of brushing off the fine sawdust that may adhere to the pieces, in the recesses of the plates or the jewel holes and pinions; except when the oil, in form of a dry crust, is not removed in the process of washing, which sometimes is the case, I never use a pegwood to peg out a jewel hole, the latter coming out of the bath perfectly clean. To most watchmakers this process appears considerable of a job. They have what they call shorter methods that are, as they claim, just as good. With a strong doubt on the latter part of the claim, I would say that, so far as the consuming of time is concerned, all depends upon how we are organized as to facilities for doing the work. On the score of cleanliness, no one will deny that the washing process is the process "par excellence," and if our object is to get a watch thoroughly clean, looking like new and without a scratch on the surfaces, I believe the washing process is the shortest one I have examined. It certainly

does not consume any more time, if we are properly prepared, than the old-fashioned brushing with chalk, etc., does. If we haven't convenient access to a sink with running water from a faucet, we may have a small side cabinet or commode in a suitable corner where the room is not so valuable, on which we constantly have two bowls of water, one clean for rinsing and the other for washing, together with a dish of soap, a glass jar containing alcohol, and another containing the solution of cyanide of potassium. This being always in readiness, it takes but a moment at any time to wash any piece, and it certainly does not consume any more time to wash the plates, bridges and wheels than to clean them properly—granting that this could be done—in any other way. Besides, to economize time, we can arrange our work in such a way that we can wash two or more watches at one sitting. Not only that, but the work of washing is so simple that any person, a boy or a girl, can be taught to do it just as well as we can do it ourselves. I may mention the fact that when I had charge of a number of workmen, I employed a girl to do the washing for all of us. Each of us would take his watches apart, making all necessary repairs while taking them down, and laying the pieces of the entire movement into the jar with gasoline. The girl would collect these jars, wash the contents of each separately, wipe and clean all the steel parts and return the pieces to each in trays, all clean and ready to be put together. On the score of safety, I do not recollect a single piece ever having been broken or lost in her washing, and she handled all the wheels and all the little screws. At another time I employed one man specially to do all the cleaning only of watches needing otherwise no repairs. He would take apart two or three of them and lay them all into the same jar of gasoline, and, when ready, go and wash them at one sitting. There is no difficulty as to separating the pieces belonging to different movements. Thus, it may be seen that the washing process offers advantages in the way of saving time which no other process does.

In order to clean a watch properly, certain precautions, as well as certain preparations, are necessary. Your alcohol, your gasoline and your water must be clean, and your cyanide must not be too strong nor

old. Your brushes, too, must be in good order. As to brushes, at least two of them are absolutely necessary, and they must be specially prepared. It is a well known fact that old brushes work better and scratch the surface less than new ones. This is because the ends of the bristles are rounded and smoothed by constant use. We can prepare new brushes, artificially, in the same way that will be much superior to old ones. We commence by selecting for the purpose only those of the finest and softest goat hair, with four rows. Taking a piece of sandpaper of medium coarseness and about a foot square, we lay it on a flat board and rub the brushes to and fro on it in every direction, just as if we intended to brush off all the sand, using enough pressure to bend the hair, so that the latter will rub on the side instead of on the ends only. After continuing this process a little while, it will be found that the ends of the bristles, instead of being square and rough, as they were when we bought them, have become tapering to a fine long and soft point, and the brush smooth as silk to the touch. Such a brush, when clean, will not leave a scratch on the most delicate surface, and it will be found that the tapering points of the bristles will go through the smallest jewel holes, enabling us to brush out any fine dust that may have remained in them in the process of drying in the sawdust. The workman may have a number of brushes thus prepared, but two are absolutely necessary—one to wash with and one to dust with—and they should alternate in the work; the one that was used for washing should, when dry, be used for dusting, and the other for washing. In this way we always have a perfectly clean brush for dusting.

In taking down a watch for cleaning and repairing, examine it well and make all the repairs before cleaning it, so as to avoid the necessity of taking it down again when clean, for some matter overlooked, which is always a source of annoyance, and makes us liable to soil it. When putting it together, oil the pivots as you proceed, for fear of forgetting one or the other. Wherever pivots run on endstones, oil should be put on the endstones before screwing them down or pushing them to place. If this precaution is neglected and the oil is put only into the oil cup of the jewel, it frequently hap-

pens that it never runs back against the surface of the endstone, and the pivot will as a consequence run dry on it. Of course, it is necessary to put oil into the cup of the jewel also, before replacing the pivot that is to run in it. It may not be amiss to add that special precautions should be taken when washing and drying the balance in order to prevent the possibility of rust settling on it or on the balance spring, it not being necessary to take off the latter when washing it. It should, in the first place, be dipped but a moment in the cyanide; then thoroughly rinsed in running water. Use plenty of soap and water in washing it, dip but a moment in the alcohol—from five to ten seconds—and dry immediately in the sawdust. To make sure of this it should be run through fresh sawdust two or three times. The same precautions are applicable to the washing and drying of the fork and pallet. Again, when brushing off the adhering sawdust, examine well and see that it is clean and dry, using the clean brush freely on it. I know workmen who dip their work in cyanide, rinse in standing water without washing and dip in alcohol and dry in sawdust. This is exceedingly reprehensible practice. They do it to save time, and at the risk of having the parts rusty in a little while afterwards.

Such, in brief, is a method of cleaning a watch which, in taking leave of the reader, I would recommend for his consideration.

CHAPTER VII.

THE LEVER ESCAPEMENT; SOME CURRENT DEFECTS IN IT, AND HOW TO REMEDY THEM WHEN POSSIBLE.

I AM convinced by the many letters of inquiry I have received for additional information since Chapter IV., article 17, "Mechanical Defects," has appeared in print, that there exists a widespread misunderstanding among watchmakers touching the general principles underlying the lever escapement. While they appear to be conscious of the fact that many watches are very defective in that part, they do not seem to know precisely in what respect they are defective, nor how to remedy the defects. This fact, together with a consciousness that the subject merits a more extended treatment than I gave space to in the above cited paragraph, has induced me to add a short chapter especially devoted to its consideration, and from the point of view and the necessities of the watch repairer in particular. To enable the latter, without the necessity of undertaking a profound study of the works referred to in footnote 10, Chapter IV., many of which may not be accessible to him, to clearly see and understand these defects and incidentally to indicate the method of correcting them, when possible, is, therefore, the object of the present lines. Of course, the importance of the consideration of these defects is appreciable especially in connection with the work of adjusting, and, therefore, forms a proper sequel to a treatise on that subject. As already frequently

hinted at in the foregoing pages, a watch, in order to keep good time, must have a good motion, and this motion must be uniform and constant, at least as much as the case permits. Nor will it avail us to obtain this motion by the substitution of a strong mainspring when the escapement is defective; for the latter will produce irregularities in the rate nevertheless.

One of the surest ways of getting a clear knowledge of the escapement is to learn to make a correct drawing of it, or to study the drawing made by some one else who understood it. This will form an ideal picture, or pattern, in the mind of the student with which he may compare the actual construction of any escapement, and which, with a little experience, he will soon learn to do. But it is not a sufficient guide. He must be able to determine proportions and angles by practical means in the finished product, and for this purpose the drawings generally found in books are of little value to him. The latter represent, so to speak, the "a priori" conditions to which the manufacturer should conform; whereas the watchmakers' analysis must of necessity be "a posteriori," that is, of the finished product, which may be, and often is, very different from the ideal, and he is called upon to determine in what respect and to what extent it differs from the latter. This is a much more difficult problem and often impossible entirely to solve.

The lever escapement may be considered under two heads, viz.: the action of the wheel and pallets, and that of the fork and impulse table. Reserving the consideration of the latter for a more practical analysis, when we come to the correcting of defects, I shall briefly review the principles underlying the construction of the former.

The functions of an escapement are three in number:

- 1. The locking;**
- 2. The draw; and**
- 3. The impulse, or lift.**

In well constructed watches, as principally made abroad, the data for these are now well established and strictly adhered to. In others we frequently find defects of the worst kind, and it is with these that we are mostly concerned as repairers. I shall consider them in the order given above.

1. The Locking.—We call “locking” the quantity by which the tooth of the wheel overlaps the pallet stone when the fork rests against the banking. If the tooth, when the wheel slips off the impulse plane of one of the pallets, should fall directly on to the impulse plane of the next pallet, there would be a recoil of the fork against the balance, and the watch would stop immediately. To avoid this, a certain amount of overlapping is necessary. This should be the least quantity that will insure safety; for the nature of the locking, combined with the draw, is a resistance to the motion of the balance, and, like the draw, is an unavoidable evil. In the best foreign watches the locking never embraces over a degree and a half, measured from the center of the pallet arbor, and in many of them it has been limited to one degree and a quarter. It differs greatly in American watches, where it is seldom found less than two degrees and more often three and even four degrees. Too much locking is generally accompanied by pallet stones that are too narrow, the misfortune of which is that, if you reduce the locking by setting the pallet stones further back into the frame, you increase the drop enormously, which occasions not only a loss of impulse, but a more rapid deterioration of the points of the teeth, not to speak of the shock to the system, the effect of which is always of the nature of a disturbance. The only correct remedy is: *wider pallet stones, with slightly steeper impulse planes.*

If the pallet stones are of the right width, the impulse planes may be ground steeper. For this purpose, however, it is necessary, in the absence of a pallet-grinding machine, to have a special fixture to the lathe enabling us to securely hold the face of the pallet to be ground against a lap. A very convenient arrangement is that of a half-open tail stock, fixed on to an extension from and at right angles to the bed of the lathe. This extension may be fastened on to the shoe, and may, for convenience of handling the work, be inclined, downwards, to the bed. The spindle to be used on this tail-stock should have a dog on the rear end, resting against a guide pin set in the rear of the tail-stock similar to the dog and guide pin in the jewelers frame or caliper. An ordinary steel or brass taper, milled down to half its

thickness at the front, and across the whole width of it, forming two planes, one longitudinally through the center, the other at right angles to it across the center, *i.e.*, two flat surfaces meeting in a corner, is used. Into this corner the pallet jewel to be ground is cemented in such a way that the driving plane of it extends just a little outside of the taper on the side turned towards the lathe head, which latter carries a zinc lap charged only with the finest diamond powder. The dog at the rear end of the spindle must be adjusted so that when it rests against the guide pin in the tail-stock, the driving plane of the pallet stone is nearly parallel with the face of the lap, yet so that the grinding will commence from the locking corner of the stone—bearing in mind that the operation we wish to perform is to remove a small wedge-shaped piece, the thick end of which is at the locking corner, dwindling down to nothing at the drop-off corner.

Various other well known and simpler means may, however, be employed to accomplish the same end.

2. The Draw. In the lever escapement, at least in portable timepieces, the locking is not sufficient to insure the safety of its action. It is necessary to produce a tendency on the part of the force exerted at the circumference of the wheel to draw the pallet on which the tooth rests, when in locking, towards the center of the wheel. This is effected by deviating the locking surface of the pallet from a radial line drawn from the center of the wheel, outside of the circumference of the latter and in the direction in which the force is exerted (see plate XV.), presenting thus, to the tooth of the wheel, an inclined plane down which it may slide. The amount of this deviation, or the degree of inclination, should also be the least that is necessary, but must be sufficient to overcome the friction of the tooth on the surface of the pallet. It is now generally conceded that 12° of inclination are enough for the purpose. On the question, however, as to whether the degree of inclination should be the same on both entering and exit pallets, there still seem to exist different opinions, some authorities claiming that, in order to make the resistance to the unlocking equal on both pallets, it is necessary to increase the draw on the exit pallet, *i.e.*, to deviate the locking surface of

the latter more than 12° . All depends upon from what point in the course of the movement of the pallets we view the incline of their locking sides. The fact is that the latter change continually, with respect to a radial line from the center of the wheel as the fork moves from one banking to the other, and that the change takes place in a contrary sense on the exit pallet to what it does on the entering one; it is least when the tooth is in locking, on the entering pallet, and becomes greater as the latter nears the point in its course where the tooth is about to pass on to its impulse plane; whereas it is greatest, on the exit pallet, when the tooth of the wheel is in locking on it, and becomes less as it moves away from the tooth. Nor can we obviate this changing of the locking sides in any manner whatever by varying their inclination.

The proper starting point for the laying out of the angle of the draw on the pallets, in a drawing, is, however, not the radial line $A c$ (Plate XV., entering pallet), but the line $c_1 m$, tangent to the locking circle $u v$ at the point m , at which point the locking corner of the pallet is when the tooth of the wheel is in locking. Similarly, for the exit pallet, the tangent to the locking circle $u v$ at the point o_2 , at which point the locking corner is at the moment of the dropping of the tooth, is the proper line from which to lay out the angle of the draw. If these two angles are equal, we can show that the mean draw, and, therefore, also the mean resistance to the unlocking, will be the same on both pallets, or, if not entirely the same, that any increase of the angle of draw on the exit pallet will make the difference greater.

It will be observed that $c o e$ (Plate XV., entering pallet) is a right angle, $c o$ being tangent to circle $u v$ at the point o , and $e o$ tangent to circle $g h i$ at the same point. But $c_1 m t$ also is a right angle, $c_1 m$ being tangent to the circle $u v$ at the point m , and $c_1 m B$ being a right angle, and $B m t$ a straight line passing through the point of tangence m . When, therefore, the pallet moves away from its locking and m coincides with o , the two right angles merge into each other and the inclination of the locking plane of the pallet to the radial line $A c$ is exactly 12° . The same will be the case in the exit pallet when the locking corner o_2 of the pallet is at the point o_1 , which point is the point of intersection of tangents $A d$

and B f, intersecting each other at right angles; the draw angle of the exit pallet will be exactly 12° as measured from the radial line A d. Now the points o and o' are points in the locking circle where the draw ceases and the tooth of the wheel is about to pass on to the impulse plane of the pallet; at that moment, therefore, the draw, and consequently also the resistance to the unlocking, is the same on both pallets. It is true that that is not the case at any other point and moment during the unlocking; the fact is that when the entering pallet is in locking its inclination to a radial line from the center of the wheel is only about $10\frac{1}{2}^\circ$; from that as a minimum it passes to an angle of 12° as a maximum. On the other hand, when the exit pallet is in locking its inclination to a similar radial line is $13\frac{1}{2}^\circ$; from that as a maximum it passes to the angle of 12° as a minimum; but this, as already stated, we cannot avoid, and it will be readily seen that by giving to the exit pallet more draw angle the case is only aggravated, *i. e.*, we are increasing the already greater resistance to the unlocking on it.

It is comparatively easy to determine the degree of inclination of the pallets in a finished product, at least sufficiently close; we have only to consider that, in Fig. 1, the angle B, being equal to the angle of inclination of the entering pallet, is 12° , is equal to angle A, and that the two together, being 24° , and the sum of the angles of any triangle being equal to 180° , the angle B O A must be 156° . This is exactly the angular measure of the space comprised by six and one-half teeth, in a wheel of fifteen teeth, and the locking side of the pallet at the moment the tooth is about to pass on to the impulse plane points, therefore, exactly to the middle between the sixth and seventh teeth, counting from the one on the pallet, backwards. When the pallets are in locking, they point a little differently, *i. e.*, the entering pallet to 3° more and the exit pallet to 3° less than 156° .

There is a defect common in the lower grades of foreign watches, and at one time in some of the best of American manufacture, and still exists in a few of them, which almost entirely obliterates the draw and makes the locking unsafe on the exit pallet, while it increases the resistance to the unlocking on the entering pallet.

erted in the direction of the tangent, may be represented by C B and D F, while the resistance of the pallets is indicated by C E and D B. These forces are equal and in contrary directions, and, therefore, produce an equilibrium. But let us substitute a smaller wheel, keeping the same center-distance, and we have the conditions illustrated in Fig. 3. Here the force of the wheel, represented by C G, and that of the resistance, on the entering pallet by C E, not being in opposite direction, cannot produce an equilibrium, but result in a movement in the direction of the arrow, that is: towards the center of the wheel. On the other hand, D F represents the force of the wheel and D B the resistance of the exit pallet, and for the same reason cannot produce equilibrium; the resultant is a tendency to a movement in the

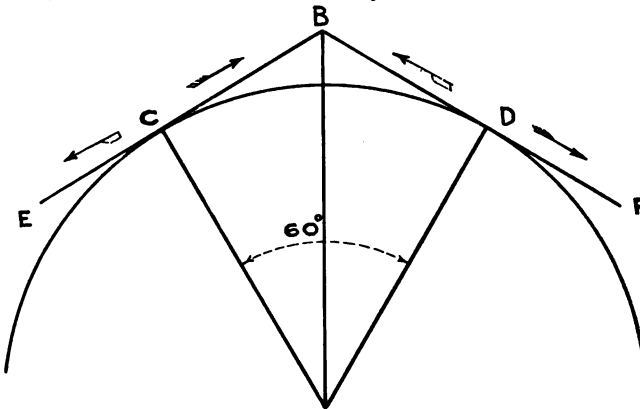

A.

FIG. 2

direction of the arrow, that is, away from the wheel. There is here created, therefore, a natural draw on the entering pallet, while on the exit pallet the tendency is to push the pallet away. If, furthermore, we draw circles from the respective centers of the pallet arbor G and B, through the locking points of the wheel, represented by the broken circles, in which circles the locking corners of the pallets move, the relative heights of the segments c d and a b on the entering pallet gives us a measure of the increase of the draw, while that of the segments c f

and *g h*, on the exit pallet furnishes us with an idea of the decrease of it.

3. The Impulse, or Lift.—We call “lift” the amount of angular motion which the wheel causes the lever to go through while passing from one pallet stone to the other. This, as a mechanical function, is wholly independent from that communicating the impulse to the balance. Without going into the reasons which have finally decided the watchmakers to adopt that quantity, I will say that in the best foreign watches ten degrees is the accepted figure. It is difficult to say what it is in some American products, but I shall assume that that quantity is intended. In an escapement in

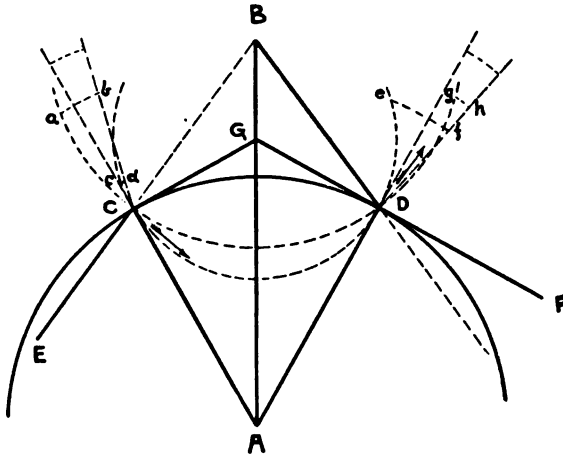

FIG. 3.

which the wheel has pointed teeth, the lift is wholly effected by the incline on the pallet stones; but in one in which the wheel has club teeth it is divided between the pallet and the tooth of the wheel. The former is now scarce and found principally, if not solely, in English watches; the latter is the all but universally adopted one and gives by far the best results. The proper partition of the lift between pallet and tooth is the result of development and has quite a history, but is now, I think, finally settled. There are, however, still those who adhere to antiquated types, or those who, having adopted a type,

do not care to make a change and possibly do not know that they could make a change for the better, and among the latter I find again some of the American manufacturers. [I here desire to beg of the reader not to conclude that my critical allusions to American watches are prompted by prejudice; I am simply stating facts, and the statements are intended in the best of spirit, and in the hope that they will be received in that sense.]

Although the repairer cannot make any changes in this function of the escapement, or correct the defects in a bad type without making an entirely new escapement, it is, nevertheless, necessary to discuss them for the sake of a proper understanding of the case. An examination of one type is sufficient to enlighten us on all the rest and to guide us to the adoption of the proper partition of the "lift" between tooth and pallet stone; this type is that in which the lift on the tooth of the wheel is nearly, if not quite, equal to the lift on the pallet stone. Plates XIII. and XIV. illustrate that type, plate XIII. the function on the entering pallet and plate XIV. the same on the exit pallet. For the sake of clearness, these are drawn on a very large scale, and the size of the plates did not permit the showing of the center of the wheel, but when we get to plate XV. the development of the drawing will be fully explained. The total lift, which is assumed to be ten degrees, is here divided between pallet and tooth as follows: 4° are given to the lift of the tooth, $1\frac{1}{2}^{\circ}$ to the locking, and $4\frac{1}{2}^{\circ}$ to the pallet. This is very nearly the partition made in some of the watches above alluded to. Now, let us examine the movements of pallet and tooth and the relation of their inclined surfaces during the lifting on the entering pallet, plate XIII. We have the tooth of the wheel, as well as the pallet, in three relative positions: when on the locking, represented by the full black lines, and at two subsequent stages in the act of lifting, represented by the broken lines. We see that when the point of the tooth slips over the locking corner of the pallet stone, the incline on the tooth performs its part of lifting wholly on that corner, and only the heel of the tooth, after it has wholly passed on to the incline of the stone, finishes the lifting on the latter. Turning to the exit pallet, plate XIV., and watching the process of lifting, we see that the point of the

tooth first glides along the impulse plane of the stone until it reaches a point a little beyond the middle of it and then the tooth turns and steps on to its heel and the latter finishes the lifting on the incline of the stone. There is a moment in the passage of the tooth across the lifting plane of the stone, that is, between the second and third positions in the drawing, when the two inclined surfaces of tooth and stone are exactly parallel, and the very next moment suddenly separate. If we consider the fact that the surfaces are always lubricated with oil, the cohesion taking place between the surfaces in contact at that moment and the disturbance through the sudden breaking of it must be considerable. I have seen the tooth of the wheel, in such an escapement, stop on the middle of the exit pallet stone, by the force of the cohesion, when the balance had been removed, though enough motive power was left to make the watch run. Nor is the action of lifting on the entering pallet stone more recommendable, though the driving planes never coincide. The most vulnerable portion of the pallet stones is the locking corner. This fact is the more serious when they are made of garnet, instead of ruby or some other equally hard stone. When the locking is to be reduced to a minimum this function may easily be interfered with by the wearing of the corner, which will certainly take place if the driving of the tooth takes place on it, as is the case on the entering pallet.

There is still another consideration to induce us to adopt a different apportionment of the lift between the pallet stone and tooth: The more lift we give the tooth of the wheel, the higher it will get; that is, the greater will be the outer diameter of the wheel. Now, the latter, at best, is of such dimension that we can, but with difficulty, make it pass the central core of the pallet frame and have room left for an arbor; the greater the diameter of the wheel, the less room we will have. The function of the lift is performed to the best advantage when the point of the tooth, after having slipped over the locking corner of the pallet stone, glides along the inclined plane of the latter, and the lift, by the tooth, is taking place wholly on the drop-off corner of the stone. This requires an apportionment of the lift to the tooth

of not more than three degrees. Too much of a reduction is not wise, neither; for the less lift we give to the tooth, the steeper will become the incline of the pallet stone. The extreme of that is reached in the English pointed-tooth type, where the lift is wholly on the pallet, and I venture to say that that is one reason why these watches invariably require a much stronger mainspring to produce a good motion.

Plate XV. represents a type of escapement, in so far as the partition of the lift between pallet stone and tooth is concerned, such as is now found in the best foreign-made watches. The total lift is 10° ; that on the wheel tooth 3° and that on the pallet stone $5\frac{1}{2}^{\circ}$, with $1\frac{1}{2}^{\circ}$ locking. The width of the tooth is $4^{\circ}.45'$, that of the pallet stone $5^{\circ}.45'$, leaving $1\frac{1}{2}^{\circ}$ for drop. The latter partition is varied somewhat, but in general the tooth is made a trifle narrower than the pallet, and frequently the drop is reduced to 1° , and the locking, as already stated, to $1\frac{1}{4}^{\circ}$. This, however, can be accomplished with safety only in the most carefully made products.

Making a Drawing of an Escapement.

—In drawing an escapement for comparison with an actual construction, the repairer should take a different starting-point from that generally found in books. It is customary to assume a quantity for the primitive diameter of the wheel and draw the escapement from that as a starting. This, to the repairer, is always an unknown quantity and impossible to ascertain by measurement. But he can, always, ascertain the center-distance, and if that were used as a starting-point and all the other quantities given in parts of the center-distance, he would have a ready and direct means of comparing any given construction. The tables of M. Grossman would be very much more useful to a greater number of workmen had they been compiled with that as the unit; and it is a fact for which I have found no sufficient excuse that the best Swiss designers start from the same assumed datum.

A drawing, to be useful, should always be made on a large scale, so as to minimize the errors arising from the imperfections of our instruments, etc. If the reader

will follow the instruction with plate XV. in hand, he will have no difficulty of understanding it.

Let $A B$ be the center-distance between wheel and pallet arbor. From B as a center, and with a radius of one-half the center-distance, draw circle $u v$, called "locking circle." From A as a center, and with a radius of 0.866 of the center-distance, draw circle $g h i$, called "primitive circle." I shall presently show how these quantities are derived. From center A draw lines Ac and Ad , tangents to the locking circle. From center B draw lines Be and Bf tangent to the primitive circle; these tangents will intersect each other at the points o and o_1 , the points of intersection also of the locking circle and primitive circle; then $B o A$ and $B o_1 A$ will be right angles, $B A o$ and $B A o_1$ will each be angles of 30° and $A B o$ and $A B o_1$ of 60° . We next determine the angular width, on the primitive circle of the wheel, of pallet and tooth. As they together, and including the angle necessary for the drop, can occupy only 12° , *i. e.*, half the angular distance between two teeth, we have, after deducting $1\frac{1}{2}^\circ$ for drop, 10.5° left to be apportioned between pallet and tooth. Of these, the pallet is usually given about 1° more than the tooth; in the present drawing the former has $5^\circ.45'$ and the latter $4^\circ.45'$. The width apportioned to the pallets is laid off to the right of the radii Ac and Ad and that apportioned to the tooth to the left of radius Ac . Next we point off from the center B of the pallet, and on the inside of tangent Be , line Bt , $1\frac{1}{2}^\circ$ for the locking, and Bw , $5\frac{1}{2}^\circ$ for the lift on the pallet; then Bx , 3° for the lift on the tooth to the outside of tangent Be . Through the intersection of lines Ac and Bx and from the center A of the wheel, we draw circle $g h z$, giving us the circle of the outer diameter of the wheel. From B as a center and through the intersections of radii Al and Al_1 with the circle of the outer diameter of the wheel draw circles $p q$ and $r s$. These are the paths in which the drop-off corner of the pallet stones move, while the locking corners move in circle $u v$. At the intersection of circle $u v$ with line Bt , on the entering pallet, the locking corner m of the latter will be when the tooth is in locking, while the drop-off corner n will be at the intersection of the circle $p q$ with line Bw . Join $m n$ and we have the incline forming the lift on the pallet. At the moment the entering pal-

let is in locking with the tooth, the drop-off corner of the exit pallet must be at the intersection of the circle of the outer diameter and the radius $A l_1$, while its locking corner, o_2 , will be at the intersection of the circle $u v$ and a line from the center B , $8\frac{1}{2}^\circ$ outside of tangent Bf . Join o_2 and l_1 and we have the incline of the lift on the exit pallet.

When the tooth is in locking on the entering pallet, the locking corner o being always on the primitive circle, its drop-off corner must be somewhere at the intersection of the circle of the outer diameter and the radius $A k$. Join $k o$, and we have the incline for the lift of the tooth. From point o as a center and to the left of tangent Ac lay off an angle of 24° , giving the front incline of the teeth. From the points m and o_2 as centers and to the right of tangents to the circle $u v$ at these points, lay off an angle of 12° for each pallet for the draw, giving the direction of the locking sides of the pallets; make the rear side of the pallet parallel and complete the rectangle. We may now prolong the lift $k o$ of the tooth and draw a circle from center A , to which the prolongation is tangent, represented by the broken lines. Prolong $m n$ and $l_1 o_2$ and draw circles, from center B , to which they are tangents, and we have the means of representing the relative positions of the inclines of tooth and pallets at any stage of their passage across each other, and we will find that at no time do the surfaces stand parallel to each other, but the locking corner of the tooth glides first along the entire length of the incline on both the entering and the exit pallets and the lift on the tooth is wholly applied at the drop-off corner of the pallets. The rest of the drawing should scarcely require any explanation. If the reader will get the fundamental principles well in mind the balance of the construction follows of its own accord. There are slight inaccuracies in the drawing, resulting from copying them on tracing paper, which the reader will excuse. There is also a slight displacement of the point of the tooth in locking on the entering pallet, which results from the draw, and is perfectly correct, but which I did not think necessary to indicate in the drawing. The latter would have to be made on a very much larger scale

to bring out such a small angle without confounding the lines.

Practical Examination of an Escapement and Method of Correcting Defects When Possible.

I shall now show how to examine an escapement in order to locate defects, and I shall submit a very simple rule for finding both the actual diameter of a given wheel and the diameter which it ought to have to be correct for a given center-distance.

We remove the balance if necessary in order to see, or, if not, we slowly move the lever from one banking to the other by rolling the circumference of the balance on

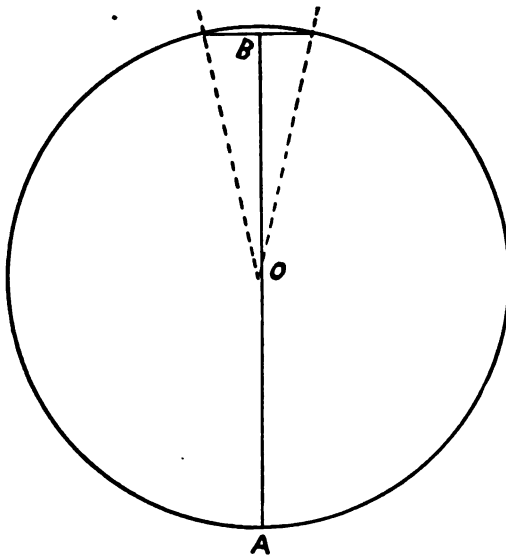

FIG. 4.

the finger and observe the function of the locking, the draw and the impulse on the pallets. We observe, at the same time, the guard pin having been made perpendicular, whether it requires any lost motion of the lever after the tooth has dropped off the pallet stone, in order

that the impulse table should have sufficient clearance. If we have to do with one of the types I have referred to in the preceding pages, we will very likely find all these functions exaggerated and defective. Suppose that we find that in spite of too much locking there is no draw on the exit pallet. We examine the direction of its locking surface when the tooth is in locking on it, in

the manner indicated in paragraph 2 and Fig. 1. If this is not as it should be, it must be made right. If, after it is made right, there should still be no draw or not enough, it is proof positive—the surface of the pallet stone being intact and the points of the teeth sharp, as well as the wheel and pallet arbors being free in their jewels—that the wheel is too small for the center-distance. There are cases in which it is advisable to replace the wheel with a larger one. To make sure, however, that this is necessary and also to ascertain the proper size of it, we have to resort to a trifle of a calculation. We have to know, in the first place, what the actual outer diameter of the wheel is that is in the watch. This we cannot ascertain by direct measurement for the reason that, in a wheel of fifteen teeth, the points of two teeth on opposite sides do not come exactly opposite each other. What we do measure is: from the point of a tooth on one side to the middle of a straight line drawn between the tops of two teeth on the opposite side, that is: the line A o B, Fig. 4. In a circle where the radius is unity that is equal to

$$1 + \text{the cosin of } 12^\circ$$

—the angle between two teeth being 24° , and that is equal to 1.97815. But when we take the diameter as unity, the measured quantity is just half that, *i. e.*, it is equal to

0.98902

or, in round numbers, **0.99** of the total diameter. This being the measured quantity of a wheel the diameter of which is 1, all we have to do to ascertain the total diameter of any other wheel is to divide the measured diameter of it by 0.99.

Next we will have to determine the proper diameter of wheel required for the given center-distance. This is a little more complicated, but I shall establish an equally simple rule that will entail no more figuring on the part of the workman. We will do well, however, before we apply it, to ascertain, as near as we can, the lifting angle apportioned to the tooth of the old wheel in question. If its function of lifting is performed as I have described in paragraph 3, on "the impulse," and illustrated on plates XIII. and XIV., we may be sure that the tooth has at least 4° lift. If, on the other hand, its lift is performed as a tooth would perform of the kind

described in the drawing, plate XV., it cannot have more than 3° lift, or near that. At any rate, we shall not make a very serious error by assuming that quantity. Fig. 5 represents the fundamental principles of the escapement as established in the drawing on plate XV., A B the center-distance, A C and A D the tangents to the locking circle and B C and B D the tangents to the primitive circle, and it is the diameter of this latter we have to find first. In the triangle B A C we have given

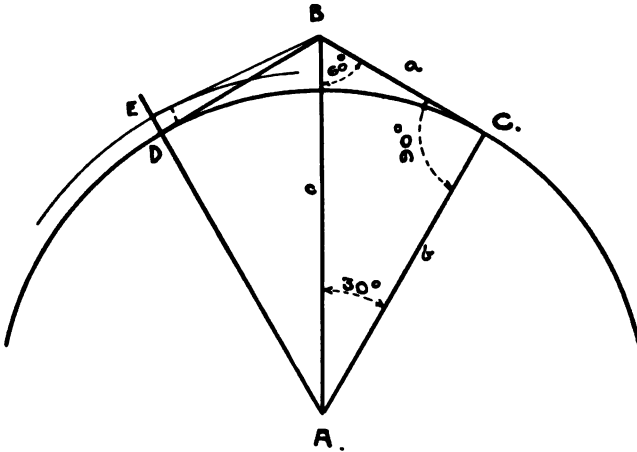

FIG. 5.

all the angles and the center-distance A B, or c, that is: the hypotenuse of a right angle triangle, and we have to find the other two sides, that is, a and b. We know that

$$\frac{a}{c} = \sin A$$

therefore $a = c \sin A$
 $= c \sin 30^\circ$

and, if we take the center-distance as unity
 $= \sin 30^\circ = 0.5$

Hence the radius of the locking circle is just one-half the center-distance.

Similarly,

$$\frac{b}{c} = \sin B$$

therefore $b = c \sin B$
 $= \sin 60^\circ = \mathbf{0.86602}$

This is the radius of the primitive circle when the center-distance is unity. In order to find the radius of the circle of the outer diameter, we have yet to solve the triangle D B E, which represents the amount of lift apportioned to the tooth of the wheel. If this is 4° , we know the angle B and the side B D, which is equal to B C, which we have just found to be $= 0.5$. To solve this triangle, we cannot use the $\sin B$ because we don't know the side B E, which is the hypotenuse, but we know that

$$\frac{D E}{B D} = \text{tangent } B$$

whence $D E = B D \text{ tang. } B$
 $= 0.5 \text{ tang. } 4^\circ$
 $= \frac{0.06993}{2} = 0.03496$

add the radius of the primitive circle $= 0.86602$
 and we have radius of the outer circle $= 0.90098$
 and for the total diameter of the wheel 2×0.90098
 $= 1.80196$
 or, in round numbers $= 1.8$

This, then, is the diameter of a wheel when the center-distance $= 1$. To find the diameter of a wheel for any other center-distance all we have to do is to multiply that center-distance by 1.8.

If the lift on the wheel tooth is only 3°

$$\text{tang. } 3^\circ \text{ divided by } 2 = \frac{0.05241}{2} = 0.026205$$

add to it radius of primitive circle $= 0.86603$
 and we have for radius of outer circle $= 0.892235$
 and for total diameter of the wheel $= 2 \times 0.89223$
 $= 1.78446$
 or, in round numbers $= 1.78$

and, multiplying any given center-distance by that num-

ber gives us the total diameter of the wheel appropriate for that center-distance when the lift on the wheel tooth is 3° . Similarly, the total diameter for any other apportionment of the lift may be found by adding one-half the tangent of that number of degrees of lift to the radius of the primitive circle and multiplying it by two and using the result as above. Thus, for instance, when the lift, on the tooth is only $2\frac{1}{2}^\circ$, the total diameter of the wheel when the center-distance = 1 = 1.775.

Having ascertained this diameter of wheel proper to a given center-distance, we can compare the ascertained diameter of the actual wheel and see whether it is too small, and how much, and replace it, if need be, with one that is right.

Of course, to be accurate in all this, we must have good measuring instruments, which are not so very plentiful. I use, for measuring center-distances, a vernier gauge with broches, or centers, in head and slide such as are used in depthing tools, reading directly to 0.05 of a millimeter and capable of reading to 0.01 by a little practice; but it is probably the only one in the world, as it was made to my order, and I have never seen any in the market. But we can always ascertain the center-distance near enough with the depthing tool and a good linear rule.

I am well aware that we can make most any watch go so that it will not stop without replacing the escape wheel when the latter is too small; but this is not the thing for me to show; my object is to show how to correct the escapement properly.

Having found the escape wheel of the proper size for the center-distance, or having replaced it by one that is of the proper size, if it was too small, we next proceed to match it with the pallets. For this purpose we must, however, first make sure that the mechanical action of the fork and impulse table is in order and make correction if not. Right here I may say that I have not considered it necessary to add a drawing illustrating the fork and table action. The reader may find this in any of the books I mentioned above, correctly given. For the purposes of the repairer, who is always dealing with the finished product, in which the proportions may vary,

a practical rule which embodies the principles is not only sufficient, but much better.

We commence by uprighting the impulse pin if it is not already so, and setting it so that the flattened front of it stands exactly at right angles to a radius. Next we examine the slot in the fork and the horns, whether they are properly freed, and we see particularly that the corners of the slot are both of exactly the same length. This being done, we put the lever and balance in place—the latter without hairspring—in the watch and close in the banking pins until the impulse pin in the table can only just pass in and out on either side, leaving the least bit of play between the outer corner of the slot and the front flat of the pin, when in the position of passing out. Often this can be done best with the watch all together, and the mainspring wound. In many watches, however, the outer diameter of the table is too large and will not let the guard pin pass out of the hollow in it when the bankings are thus closed in. To avoid interference from that source, the guard pin may be removed, or bent back so that it cannot come in contact with the table at any time; and, when replaced, after the escapement is in order, the diameter of the table should be reduced, if necessary, and care should be taken that the hollow for the passage of the guard is wide and deep enough so as to avoid contact with it when passing by.

The bankings being limited thus to just the amount of angular motion of the fork necessary to let the impulse pin pass in and out of the slot freely, we replace the escape wheel also and wind the mainspring a trifle, and we slowly move the fork from side to side by rolling the balance with the finger or a pointed pegwood and observe how the functions of wheel and pallets are performed, and adjust the pallet stones by moving them forward or backwards or sideways, as the case may require, until all the functions of locking, draw and impulse are properly performed. When this is the case the beat of the watch will be light, clear and instantaneous, without any of the clattering noises that we hear in defective escapements, and the balance will have a good motion. This, of course, requires considerable skill and no small amount of patience sometimes, but it is the

only process known to me to make some watches go right. True, the man who has to do that a great deal—and it is of frequent occurrence, and millions of watches that need it pass into the market to perform as best they can without it—often wishes he had the manufacturers of them across his knees, particularly when they originate in large factories and are claimed, in their price lists and catalogues, to be “fully adjusted.”

To facilitate the moving of the pallet stones, a very simple and inexpensive means will suffice. Take a brass plate five inches long by an inch and a half wide and about one-eighth of an inch thick; lay it across a stand about four inches in height, a sheet-iron tube or anything that will allow you to put an alcohol lamp under it; place a little shellac on it, and the pallet frame holding the stones you want to move alongside of it. When the free shellac begins to melt, you can remove the lamp, the brass plate retaining the heat long enough for the operation to be completed without any haste and in comfort and as many times as may be necessary. It may be necessary, after we have closed in the bankings and adjusted the fork with the impulse pin, to open them again a trifle in order to make the wheel pass the pallets. If that is the case, and the locking on the pallets is then just right, it shows that either the fork is too short or the jewel pin is set too near the center. In either case it will suffice to move the latter a little further out, *i.e.*, make the impulse radius of the table a little longer. When, after the guard pin is replaced or straightened, it is found that the table has not sufficient freedom, it must be reduced in diameter, which can best be done by grinding it with a lap in the lathe and often on the balance arbor itself.

Such are the most serious defects in the lever escapement and the method by which they can be remedied by the repairer. There are minor defects in plenty which do not come within the scope of the task I have set before me and which the intelligent workman can, no doubt, correct without my assistance.

[THE END.]

PLATES.

Plate I. Illustrating table 2.

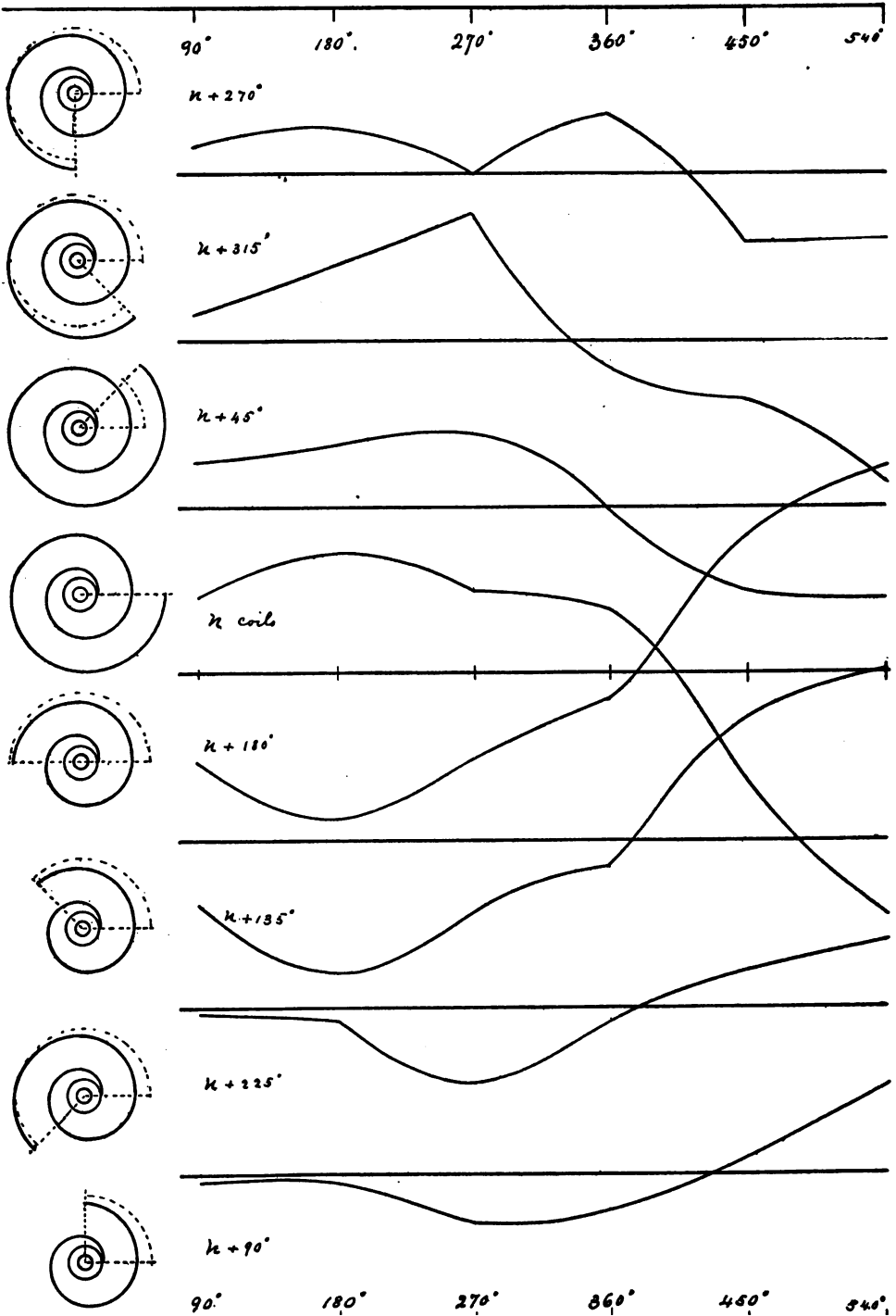

Plate II. Illustrating table 2.

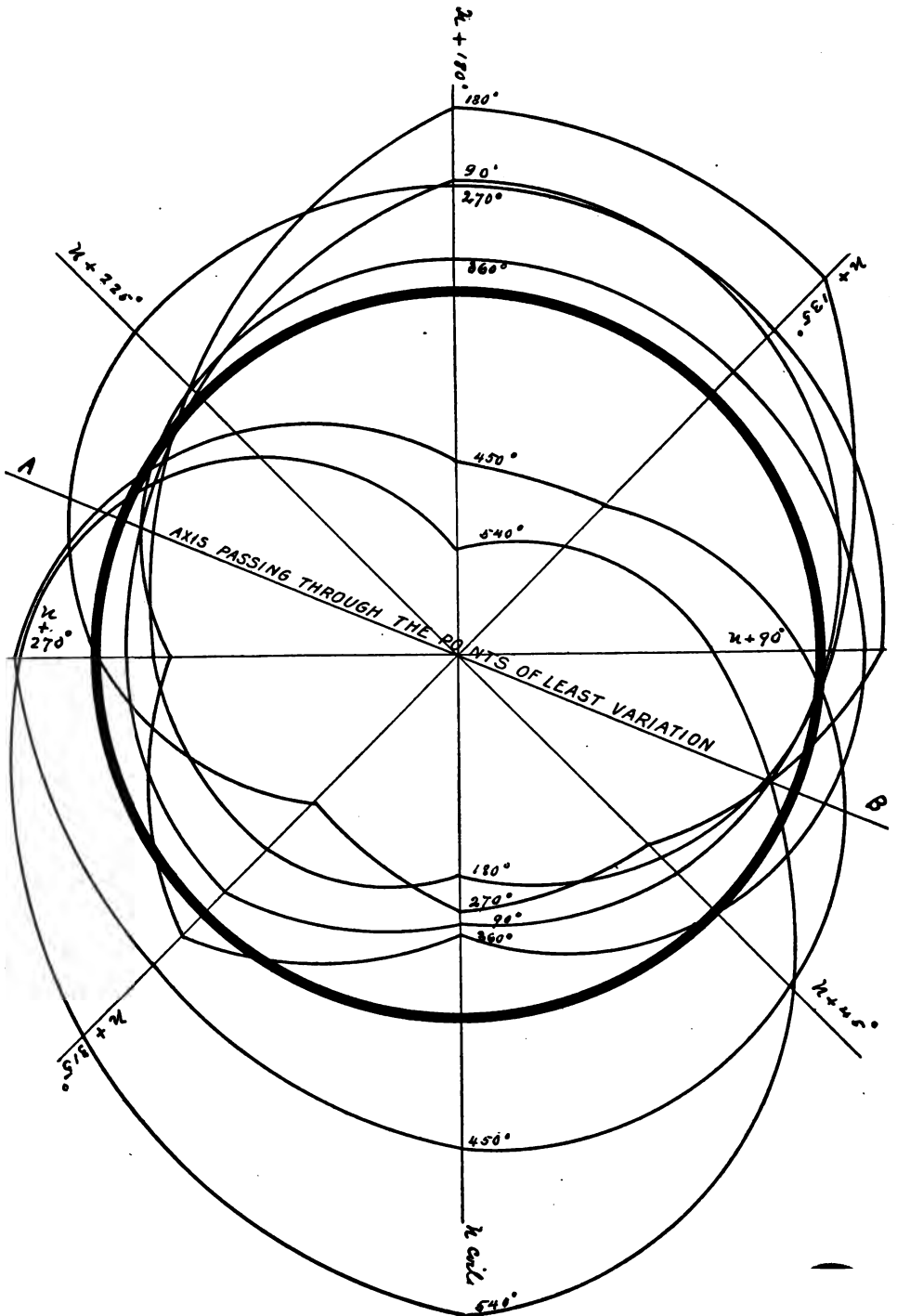
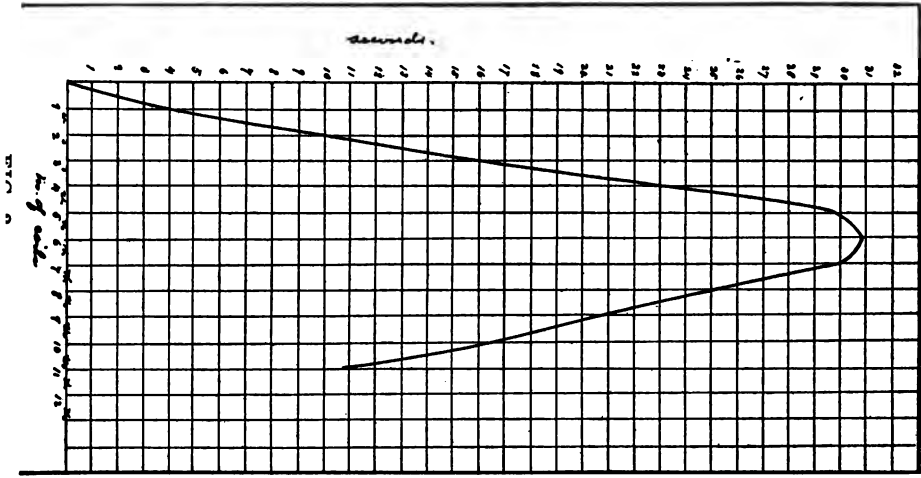
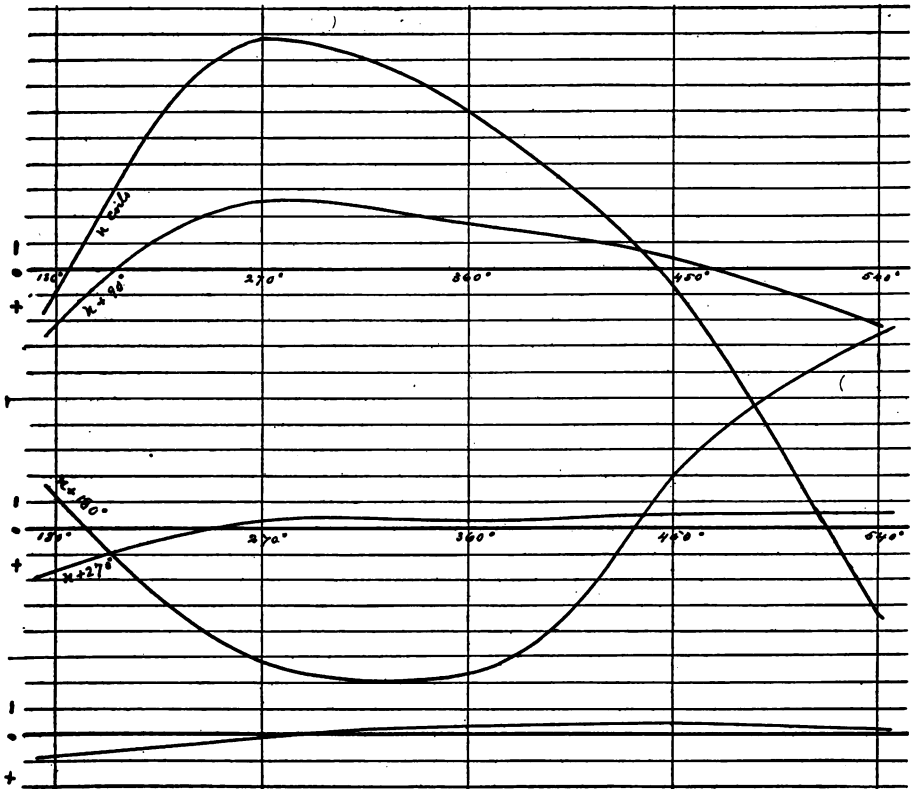

Plate III.



GRAPHICS SHOWING THE ANISOCRONISM OF A CYLINDRICAL SPRING WITHOUT TERMINAL CURVES.



THE SAME SPRING WITH THEORETICAL TERMINALS.



Plate IV.—Position Error of Flat Spring, Illustrating Table 5.

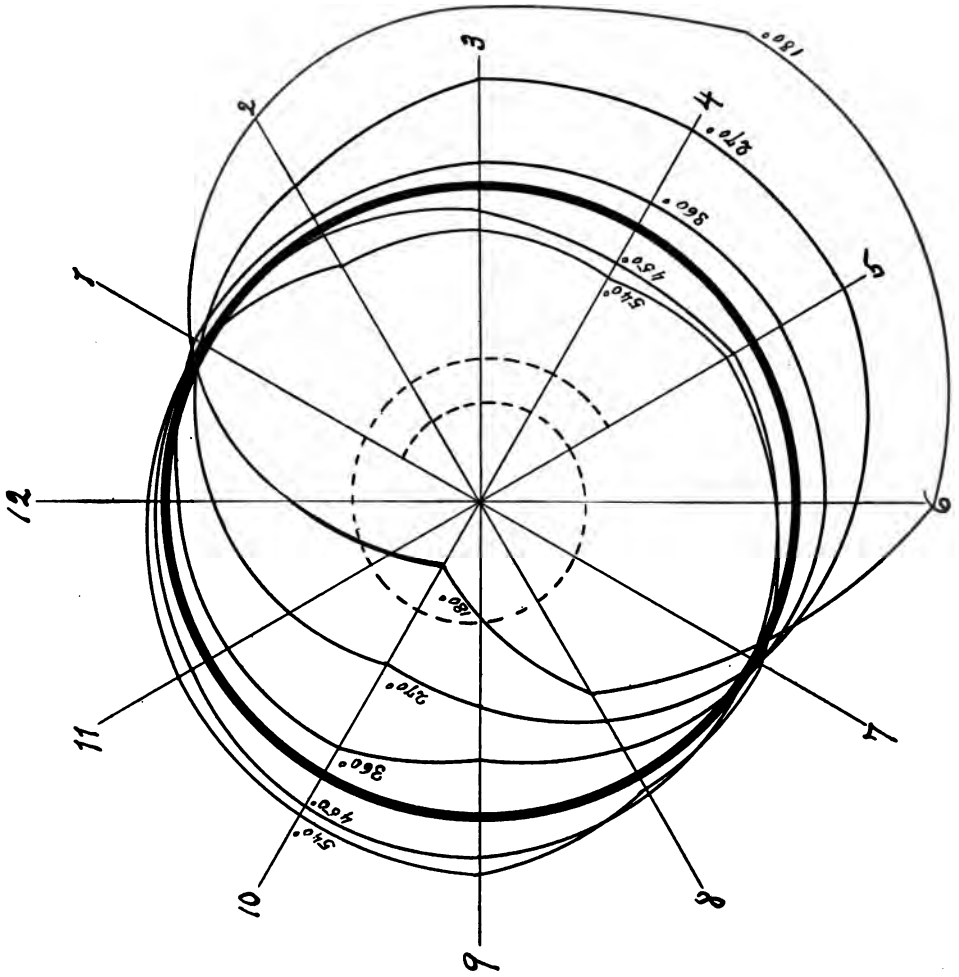



Plate V.—Position Error of a Bréguet Spring, Illustrating Table 6.

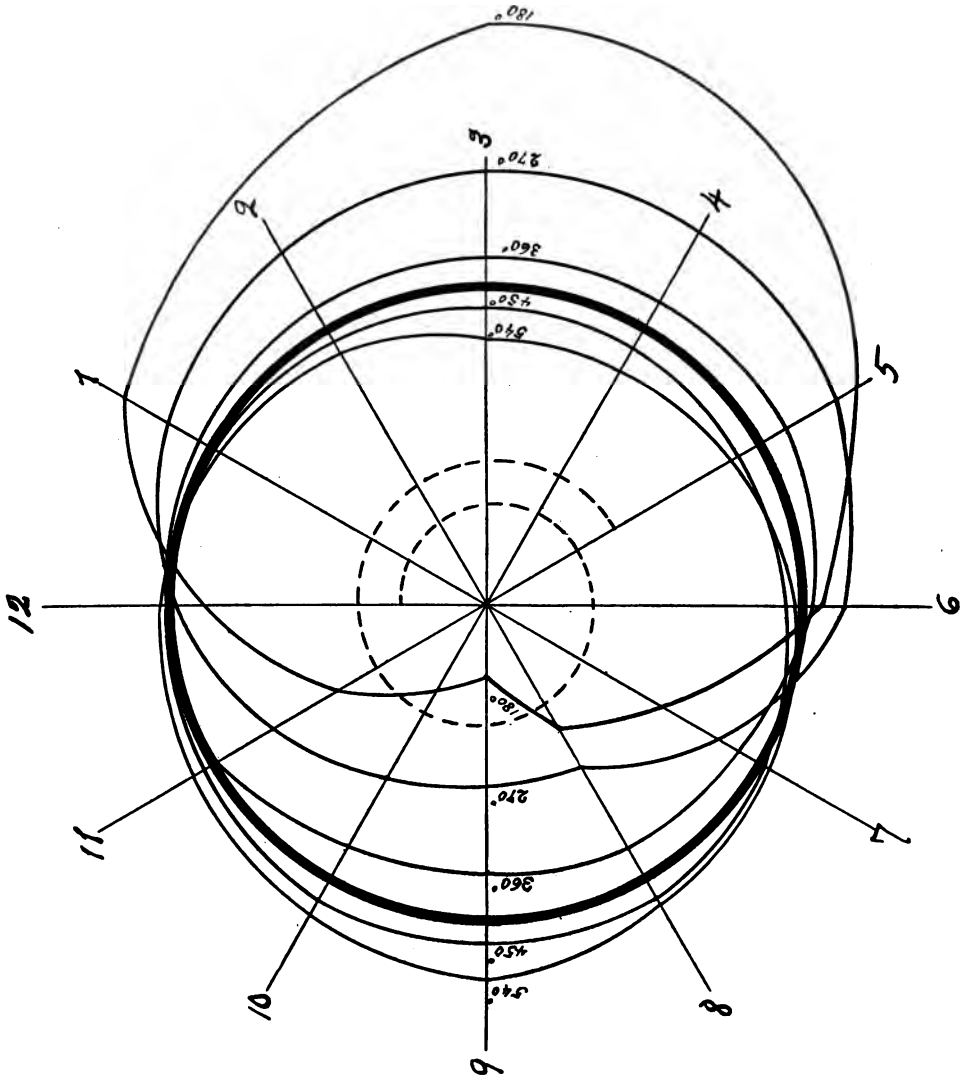

Plate VI.—Position Error of a Cylindrical Spring,
Illustrating Table 7.

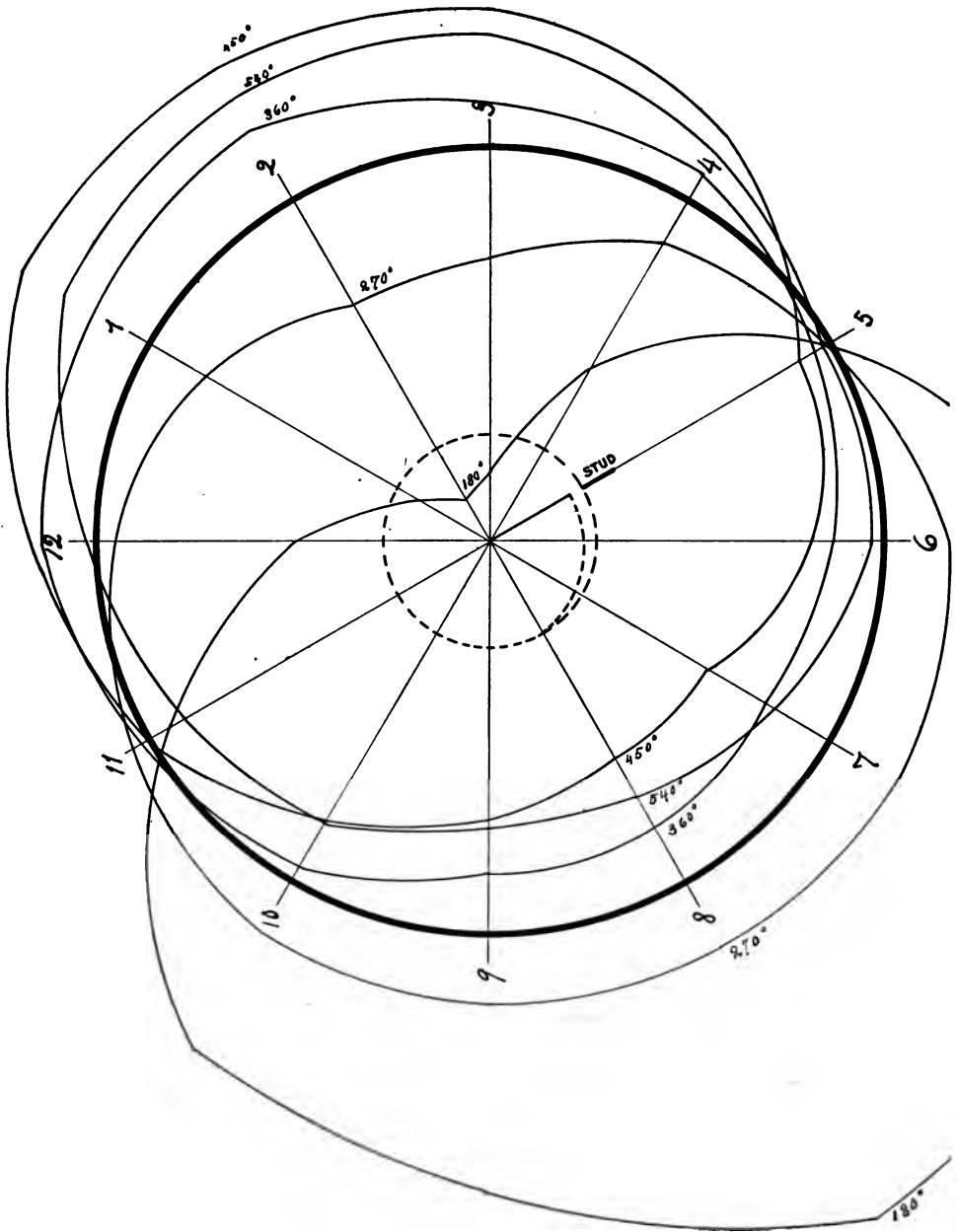
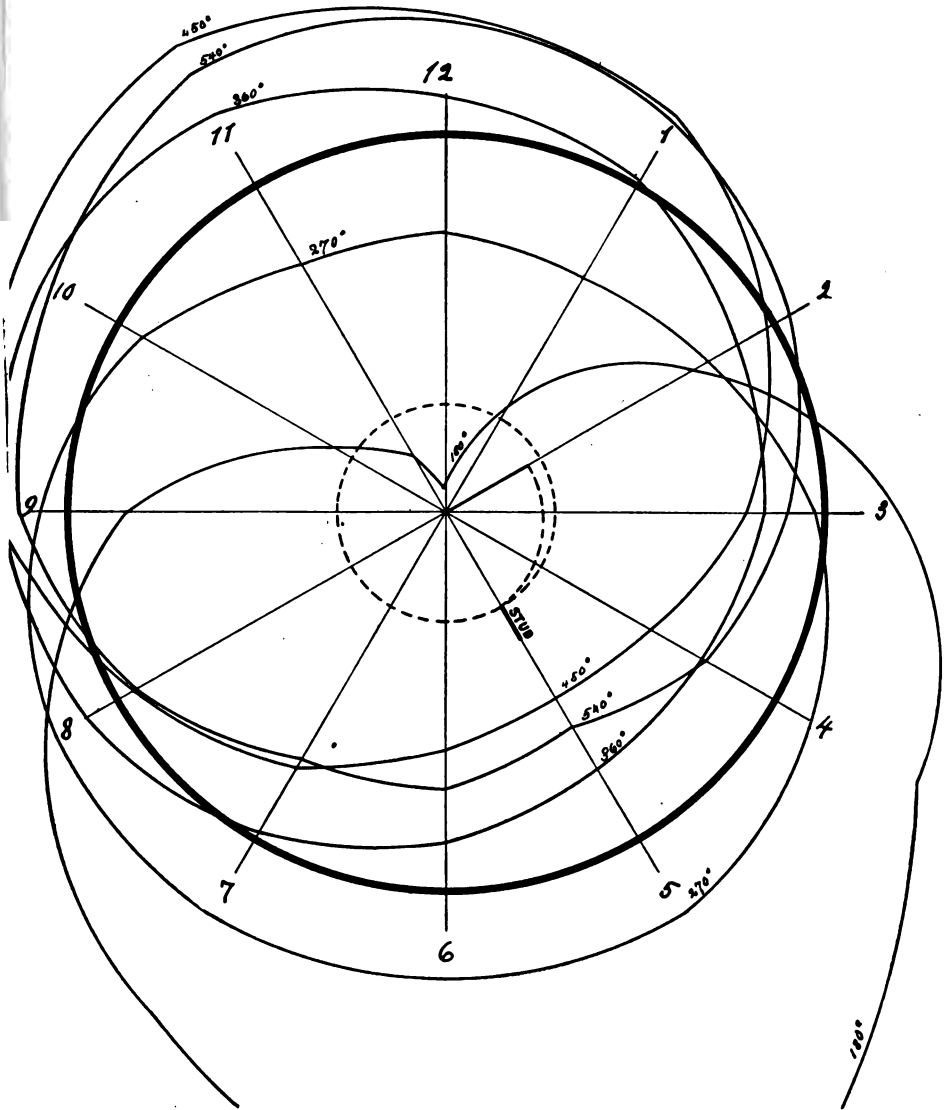

Plate VII.—Position Error of a Cylindrical Spring,
Illustrating Table 8.



1

Plate VIII.—Position Error of a Cylindrical Spring,
Illustrating Table 9.

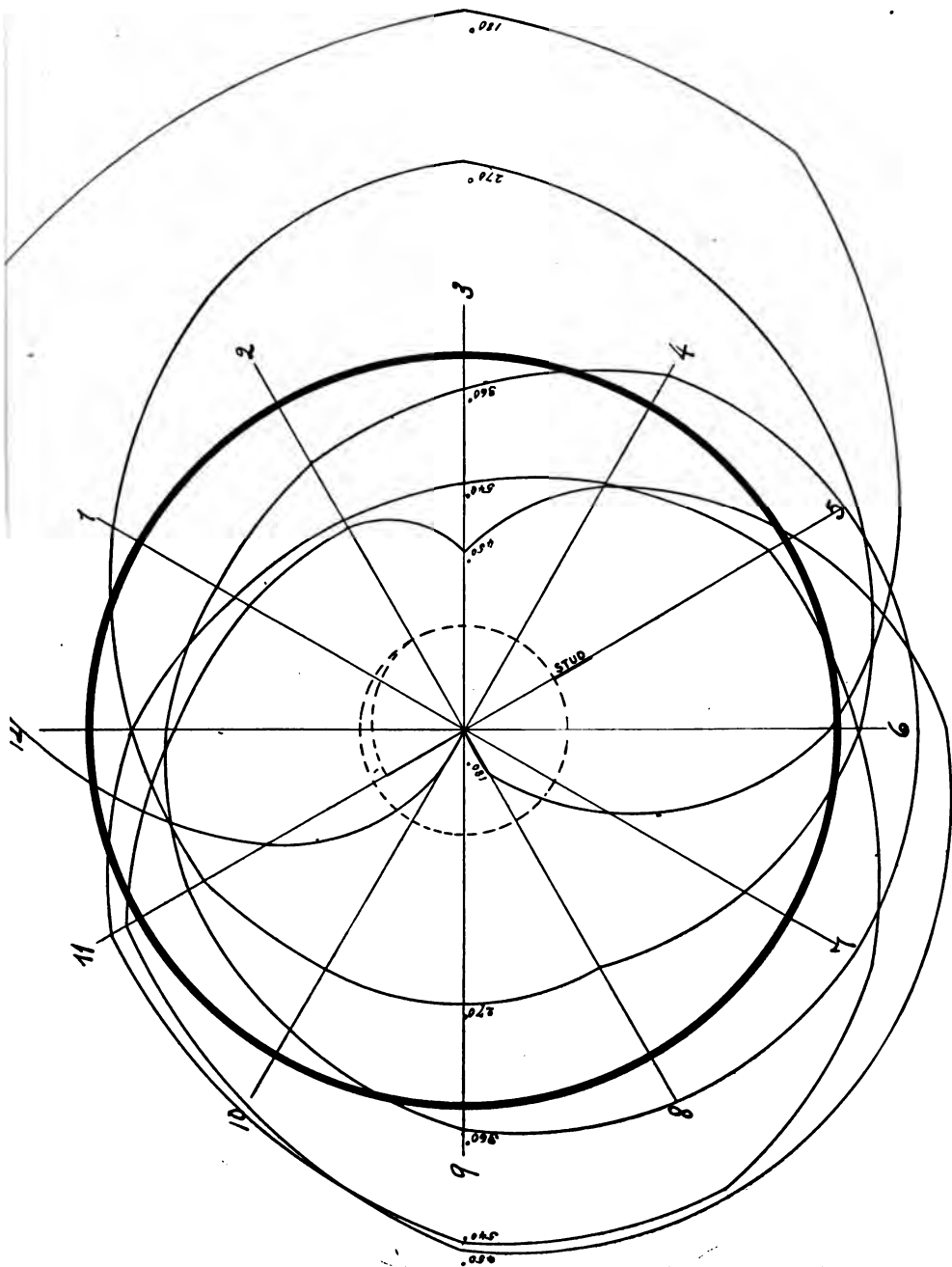



Plate IX.—Position Error of a Cylindrical Spring,
Illustrating Table 10.

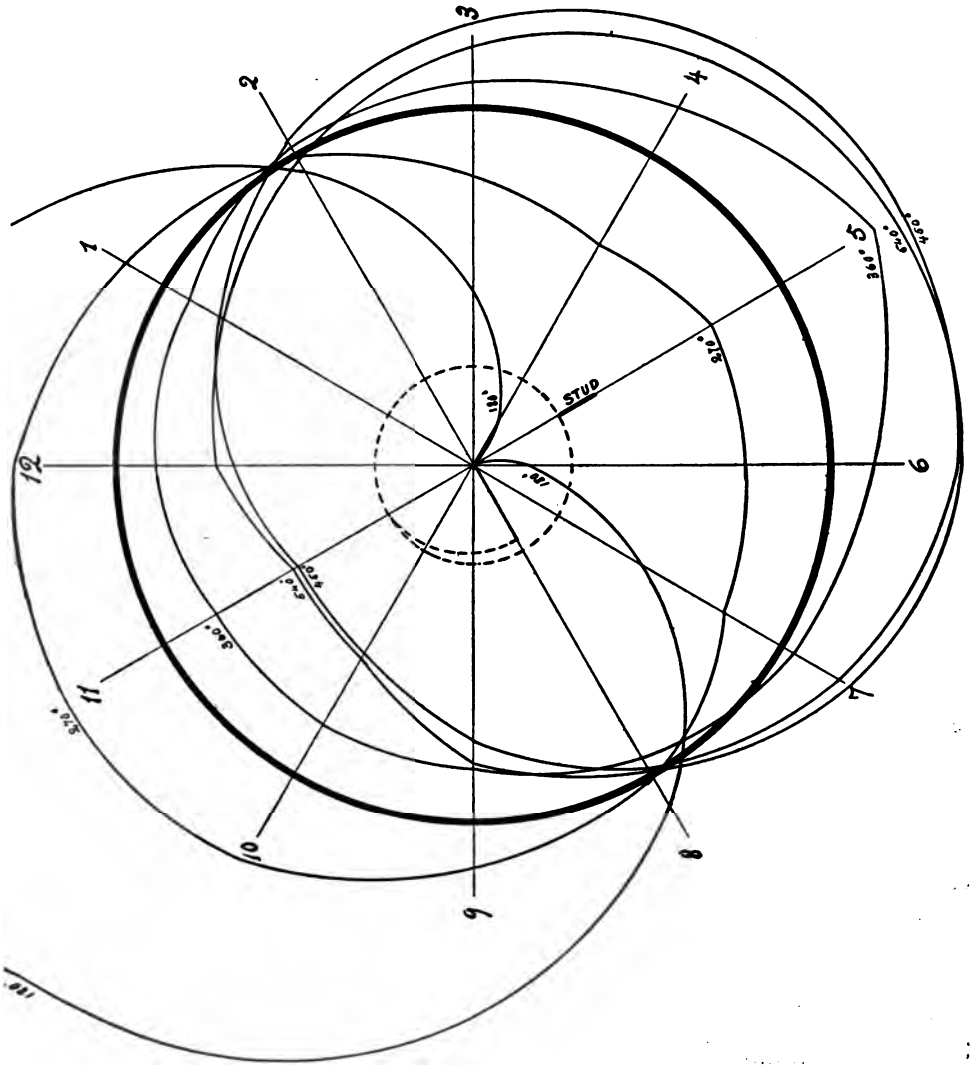
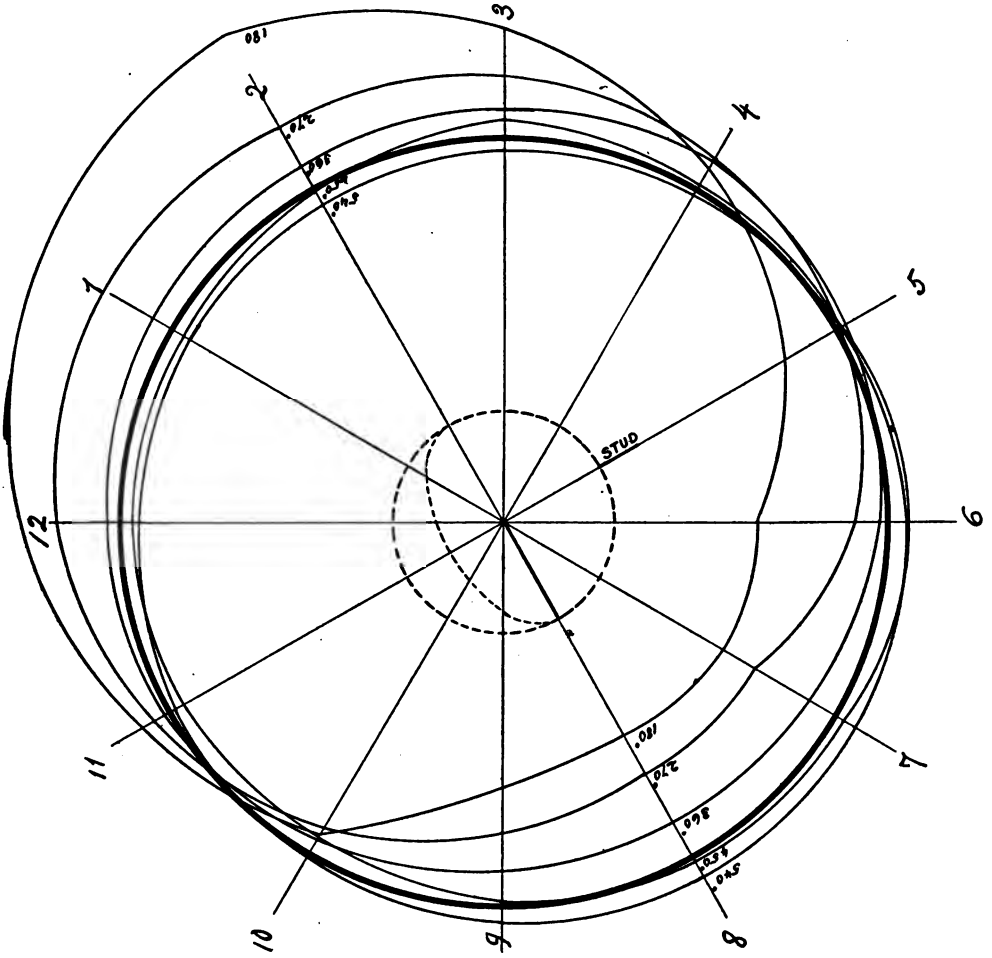



Plate X.—Position Error of a Cylindrical Spring with Theoretical Terminals, Illustrating Table 11.



Vertical line on the left side of the page.

Plate XI.—Theoretical Curves.

1

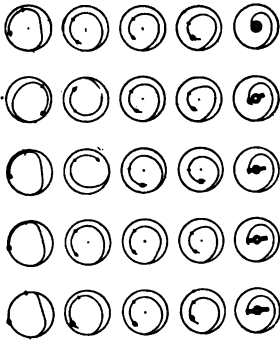

2

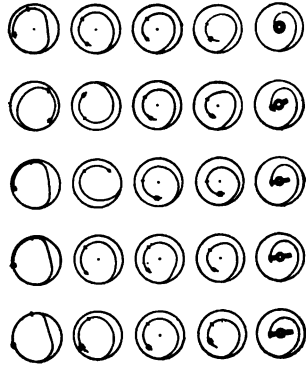

3

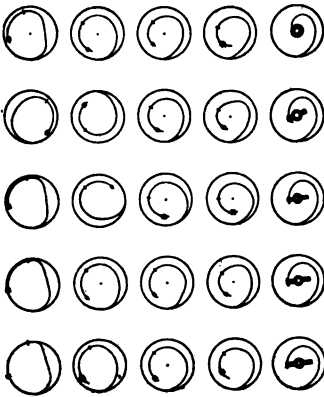

4

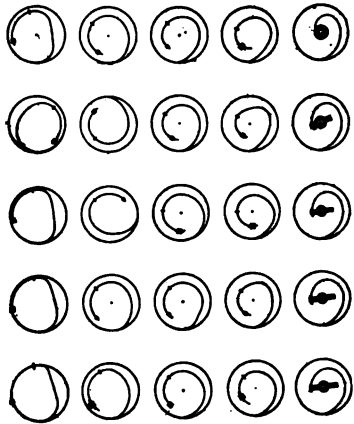

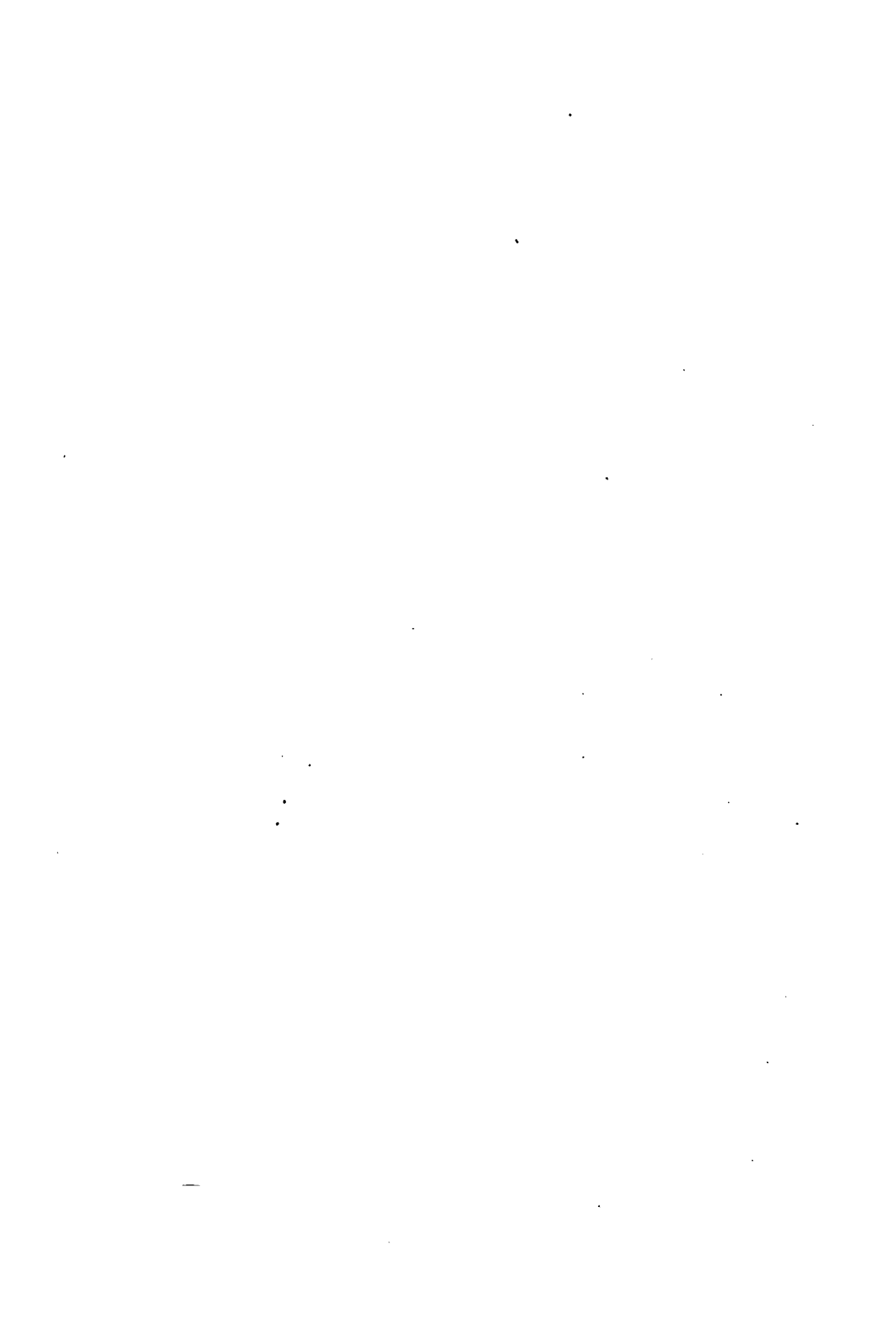
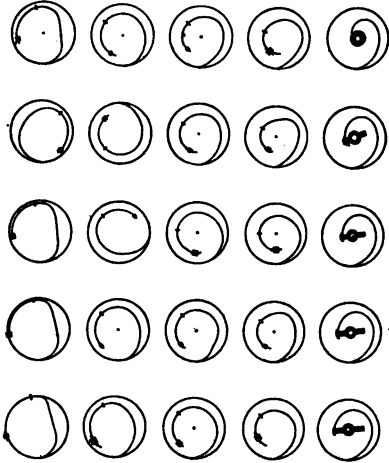
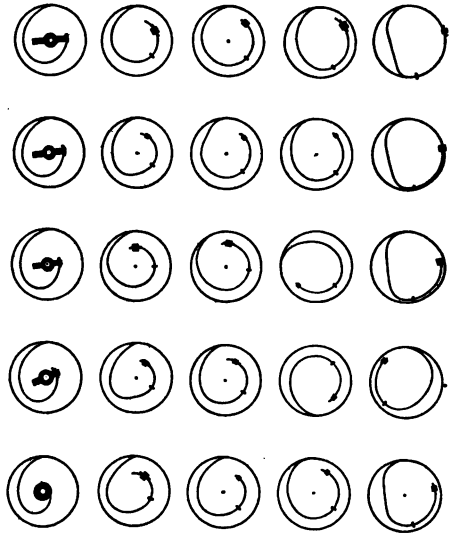

Plate XII.—Theoretical Curves.

5



7



6

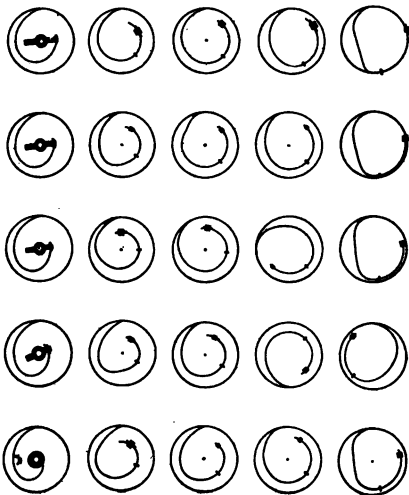

8

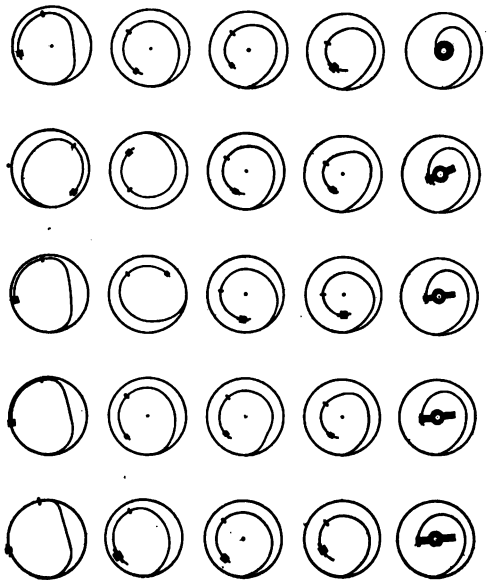



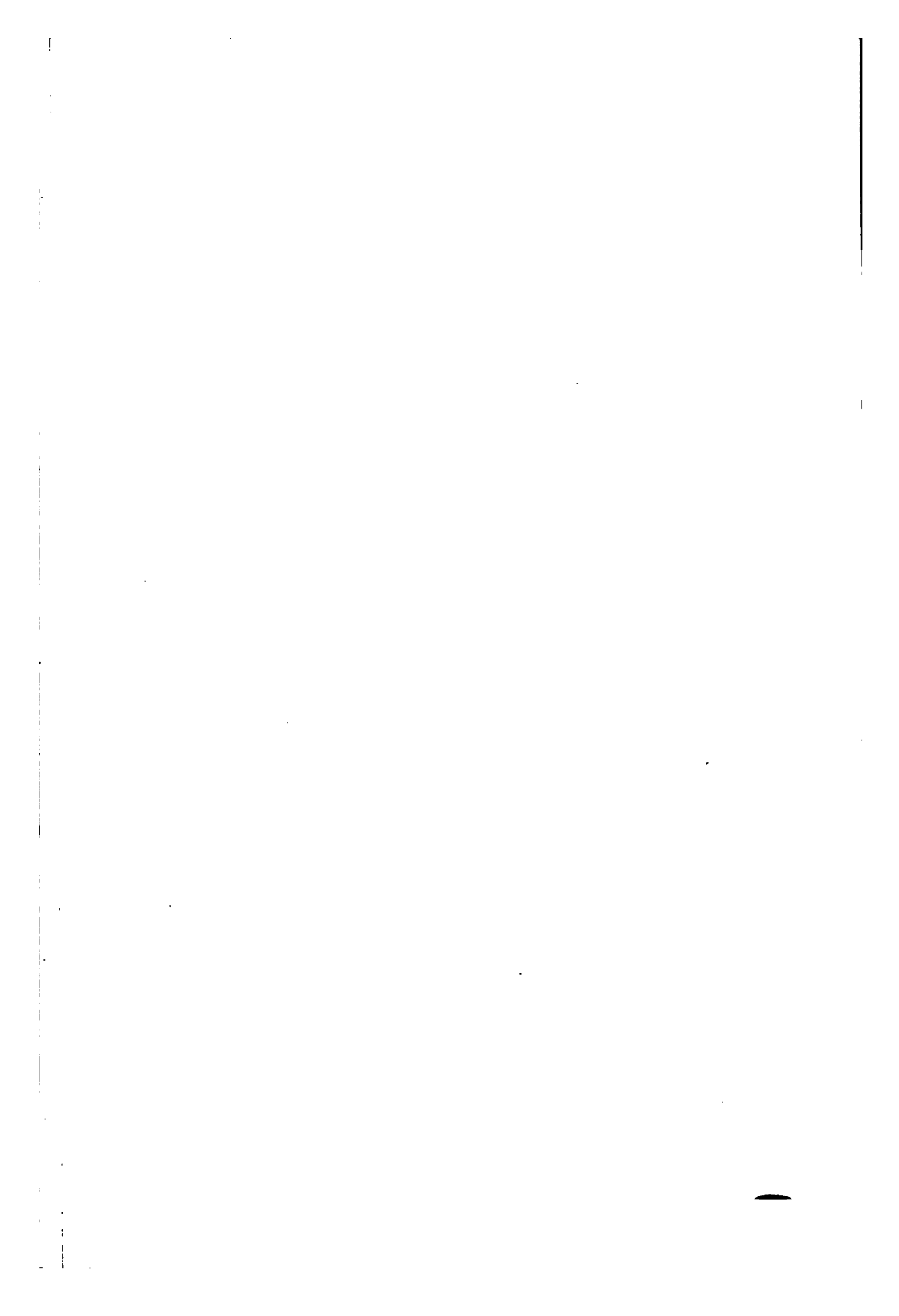

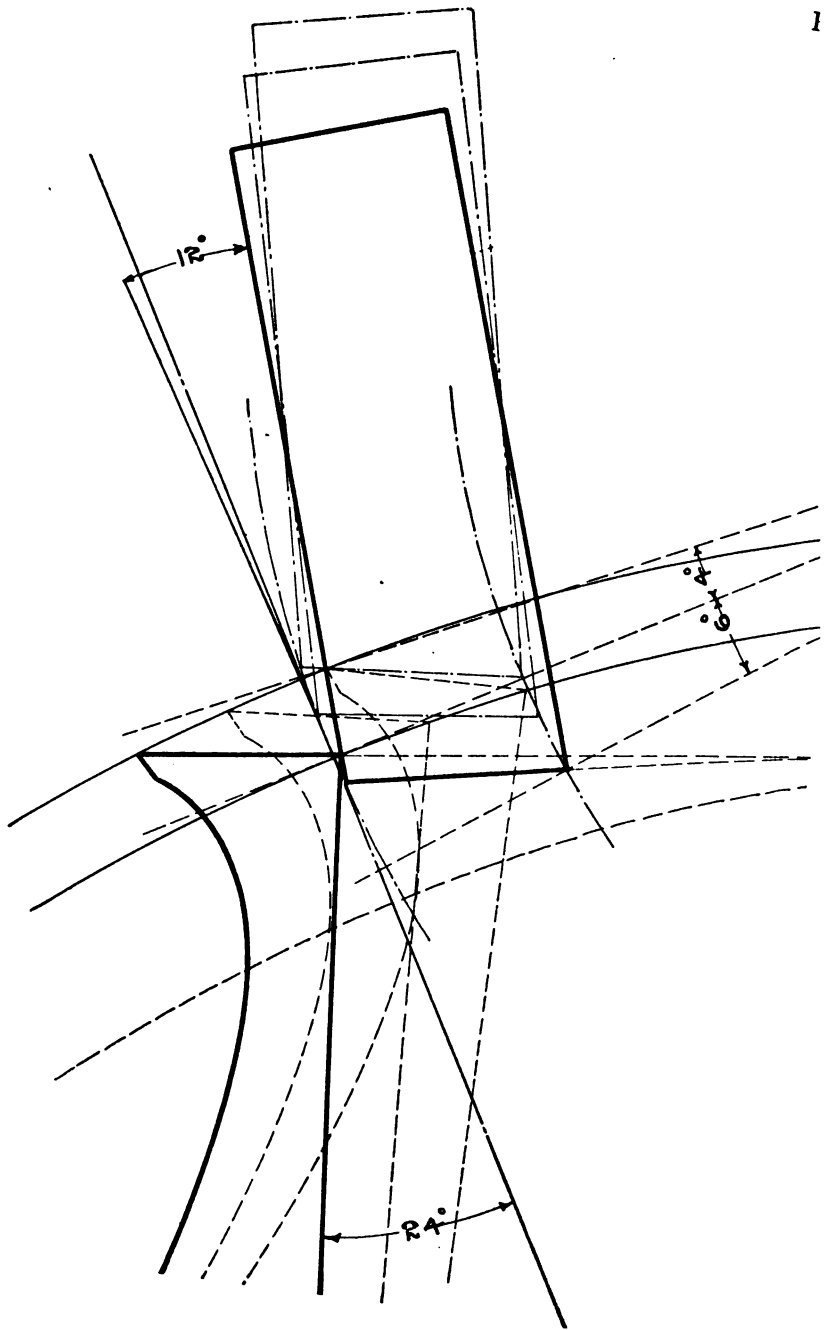

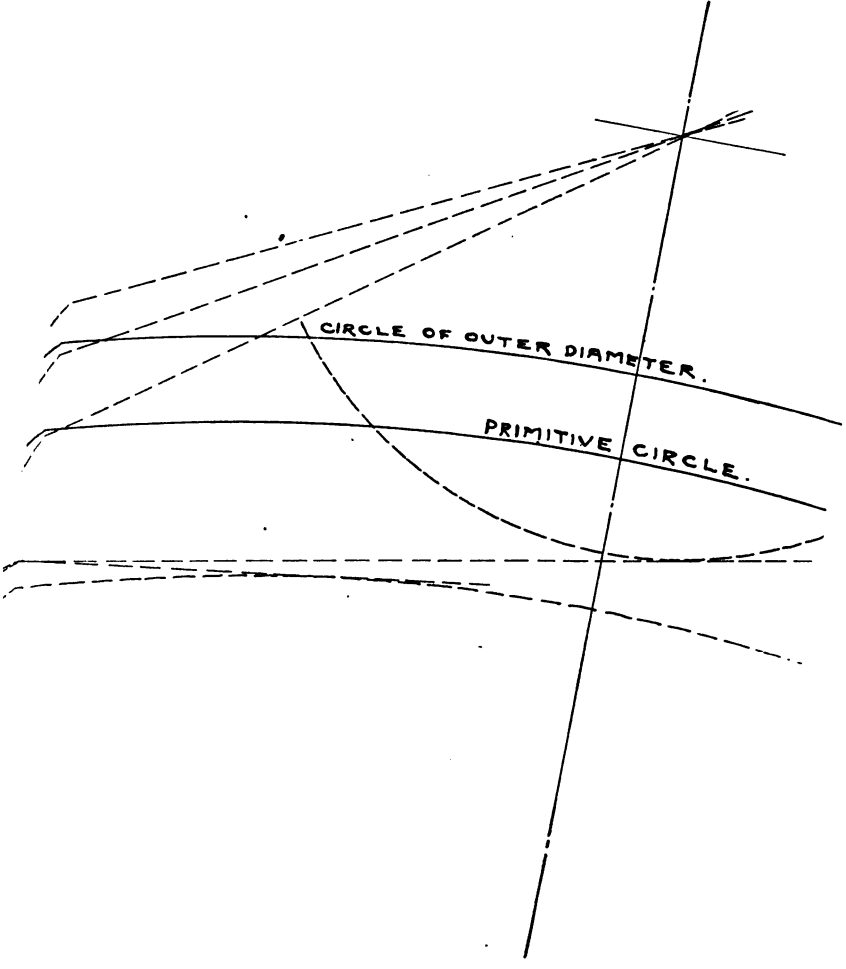

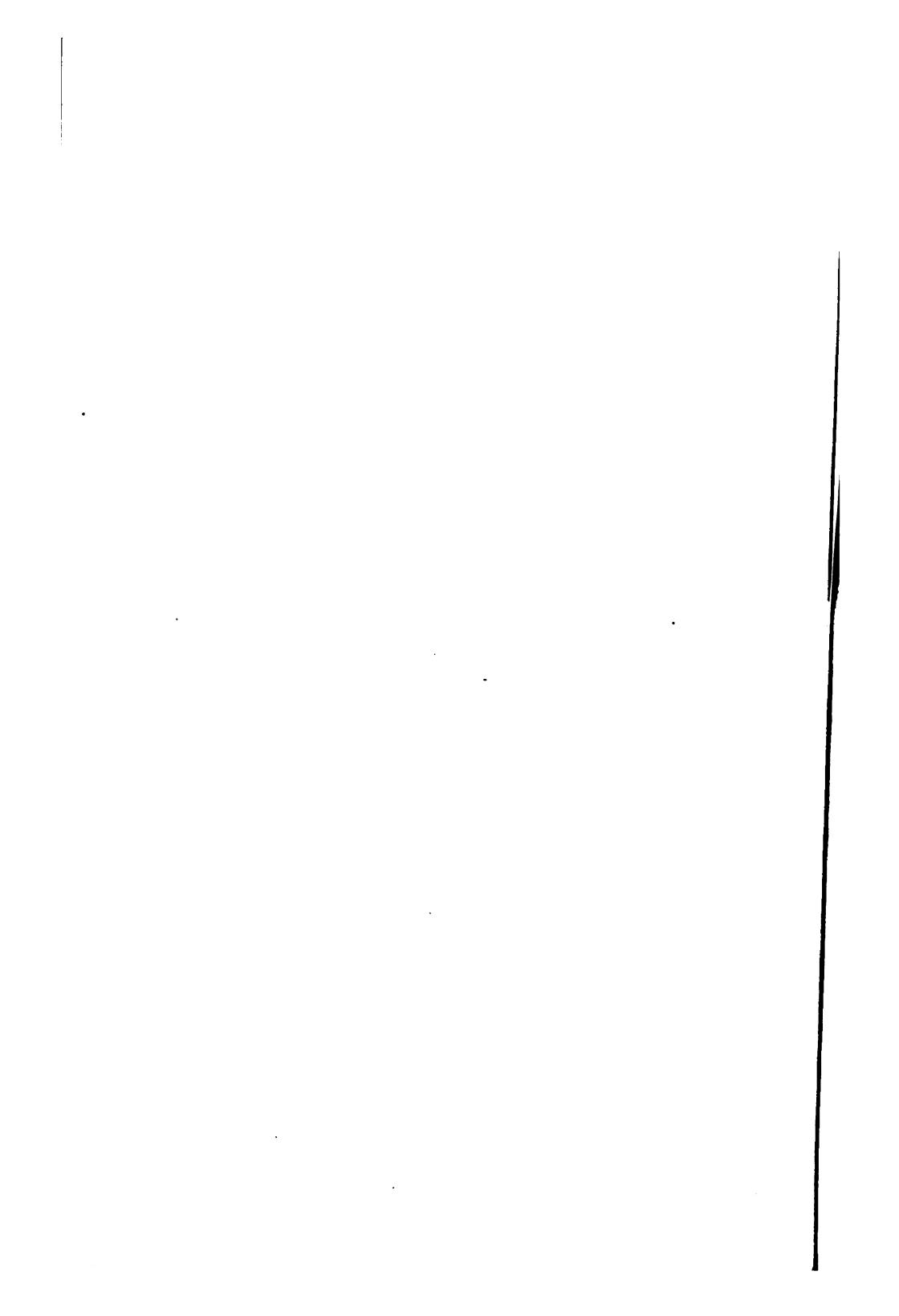

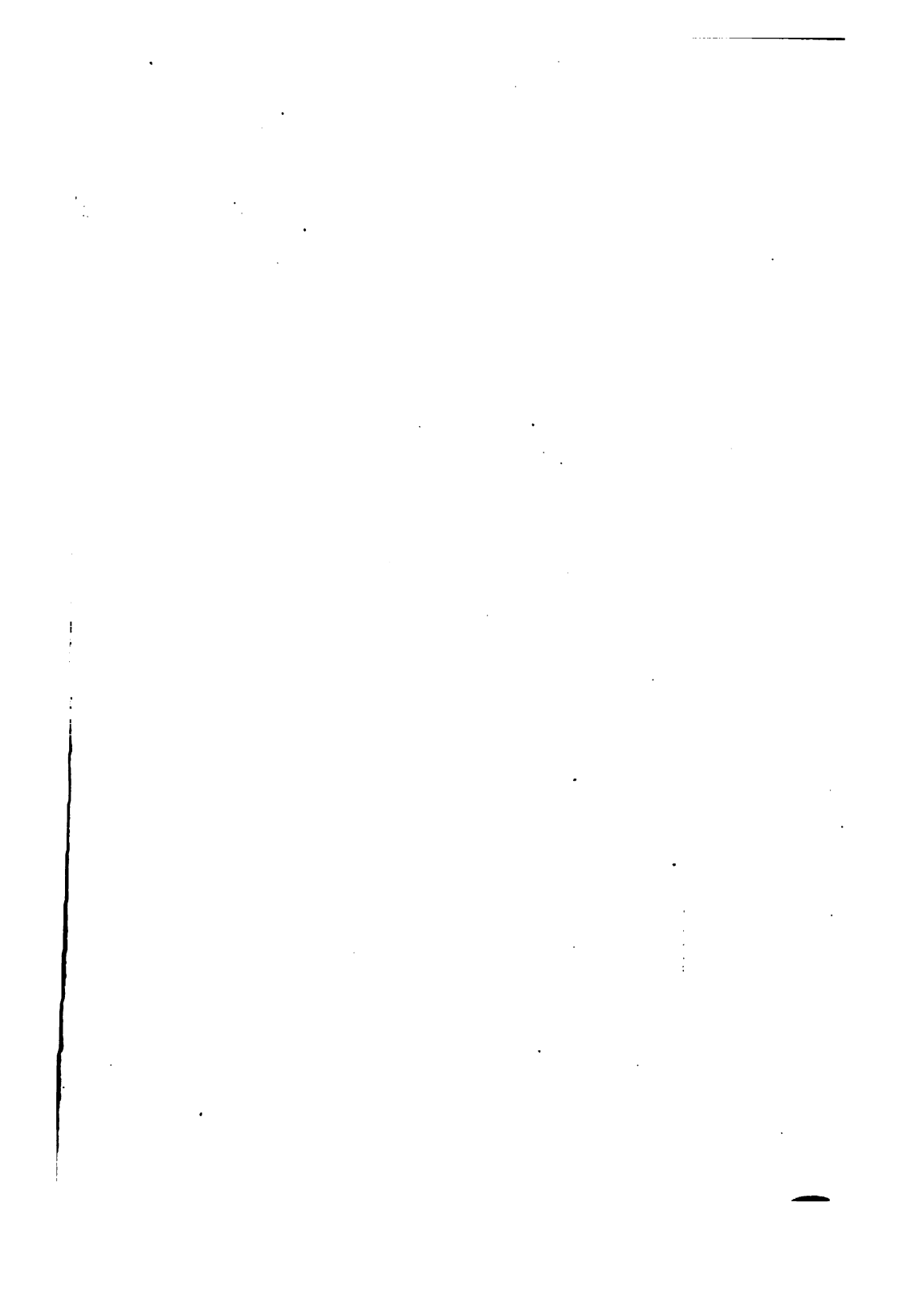

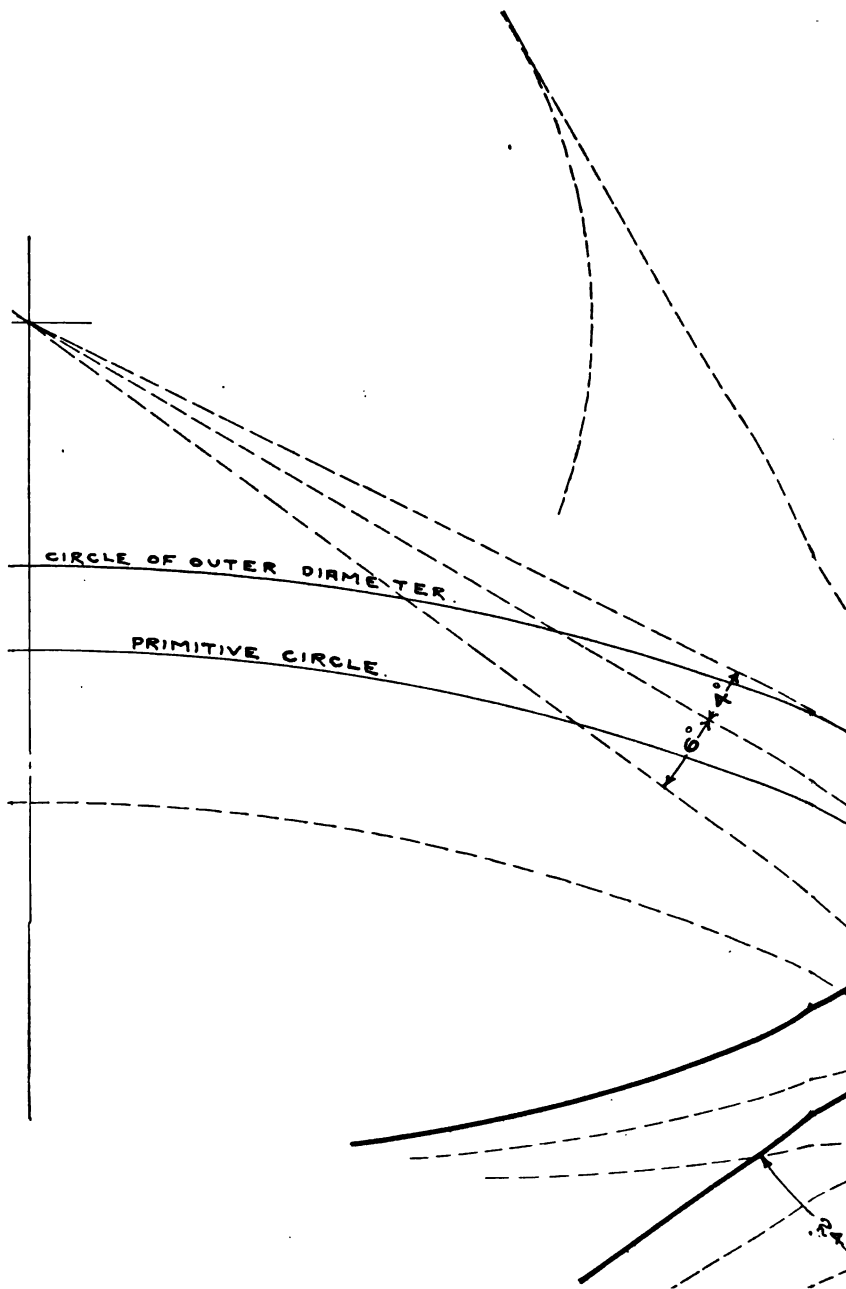

FE XIV.

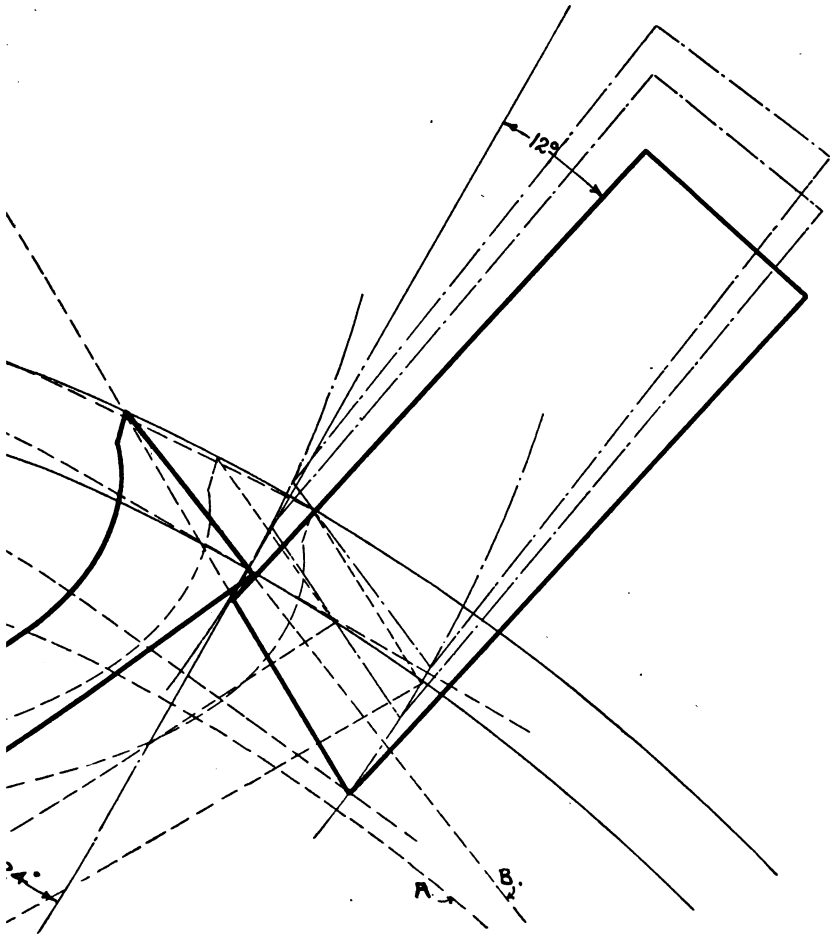

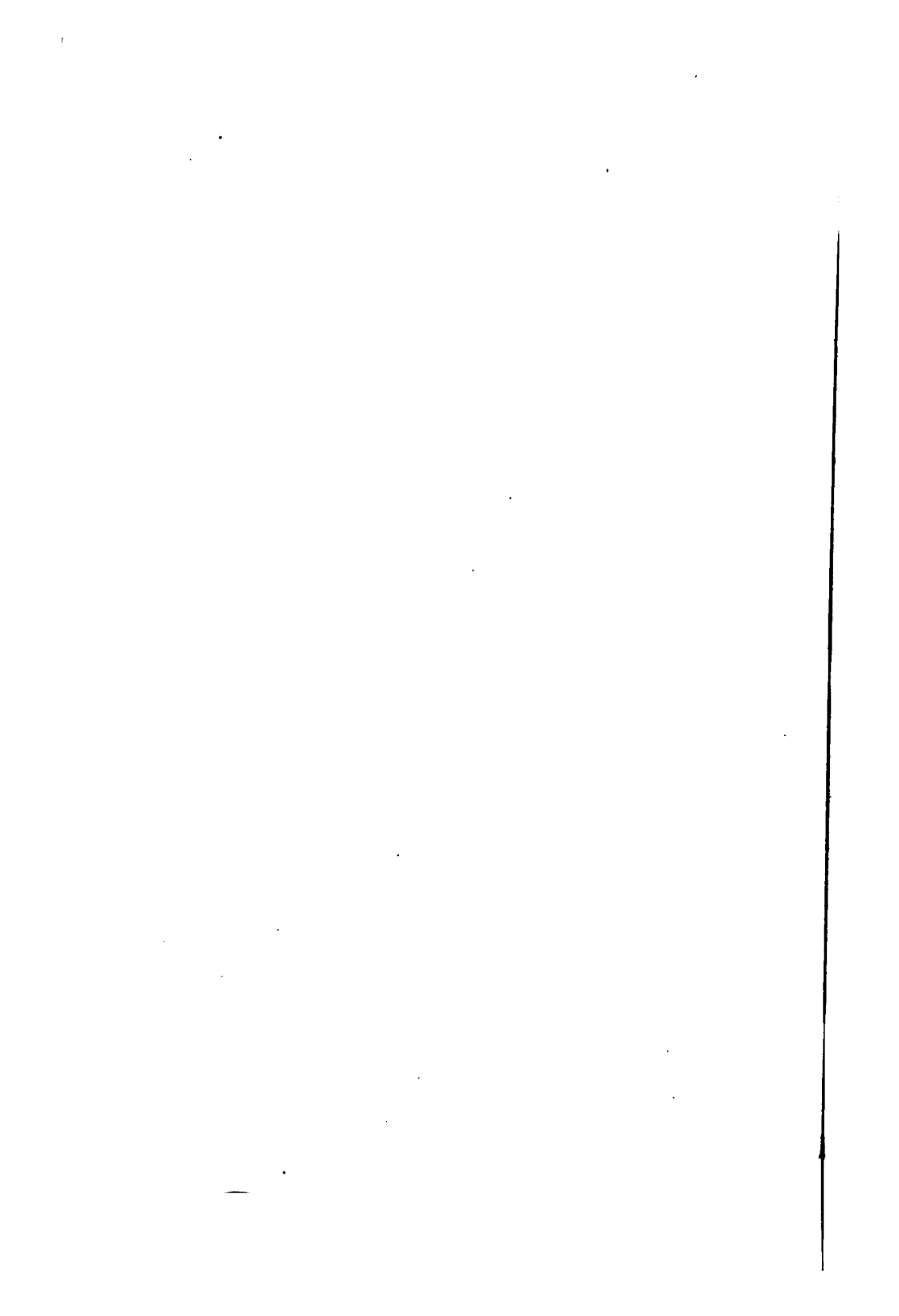



PLA

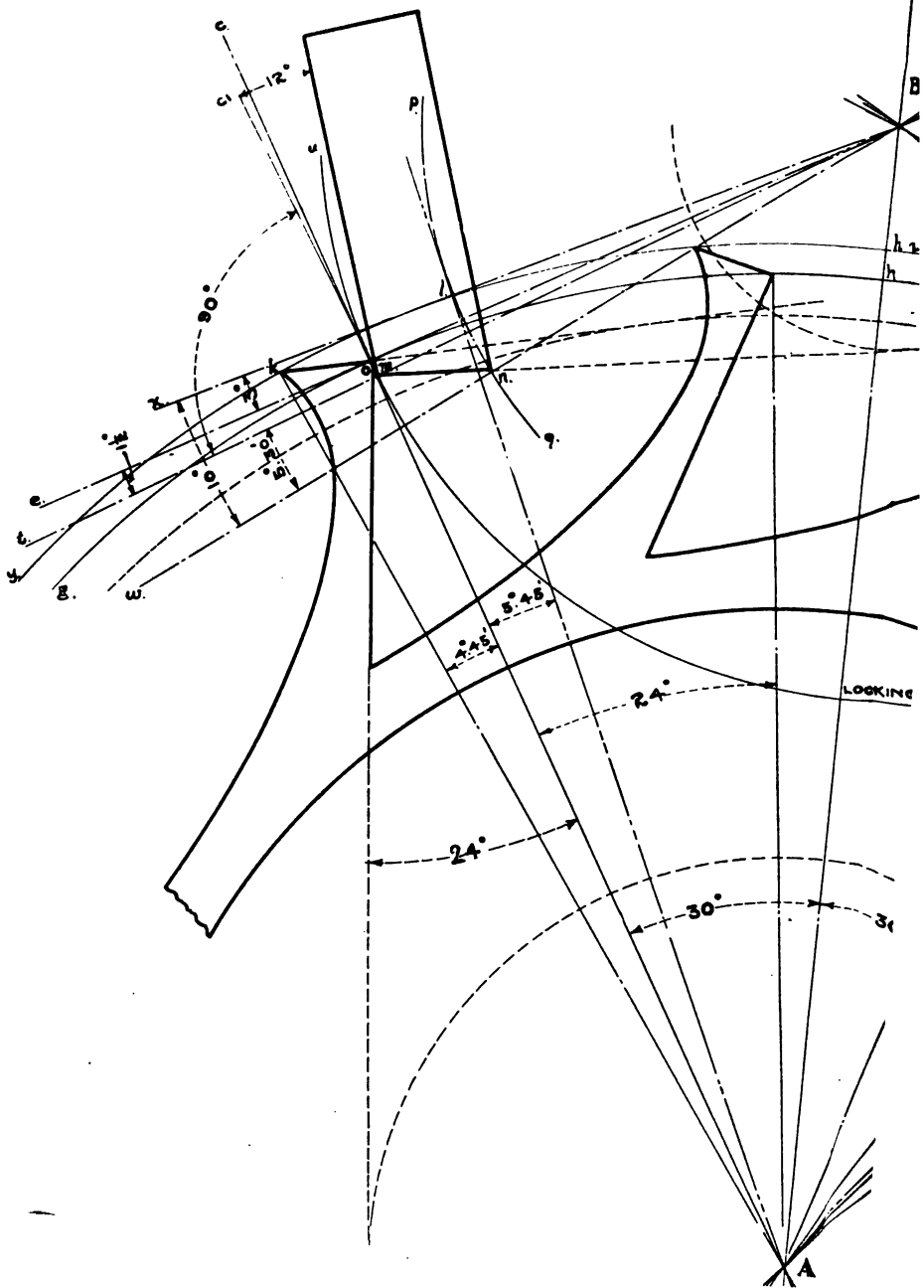

XV.

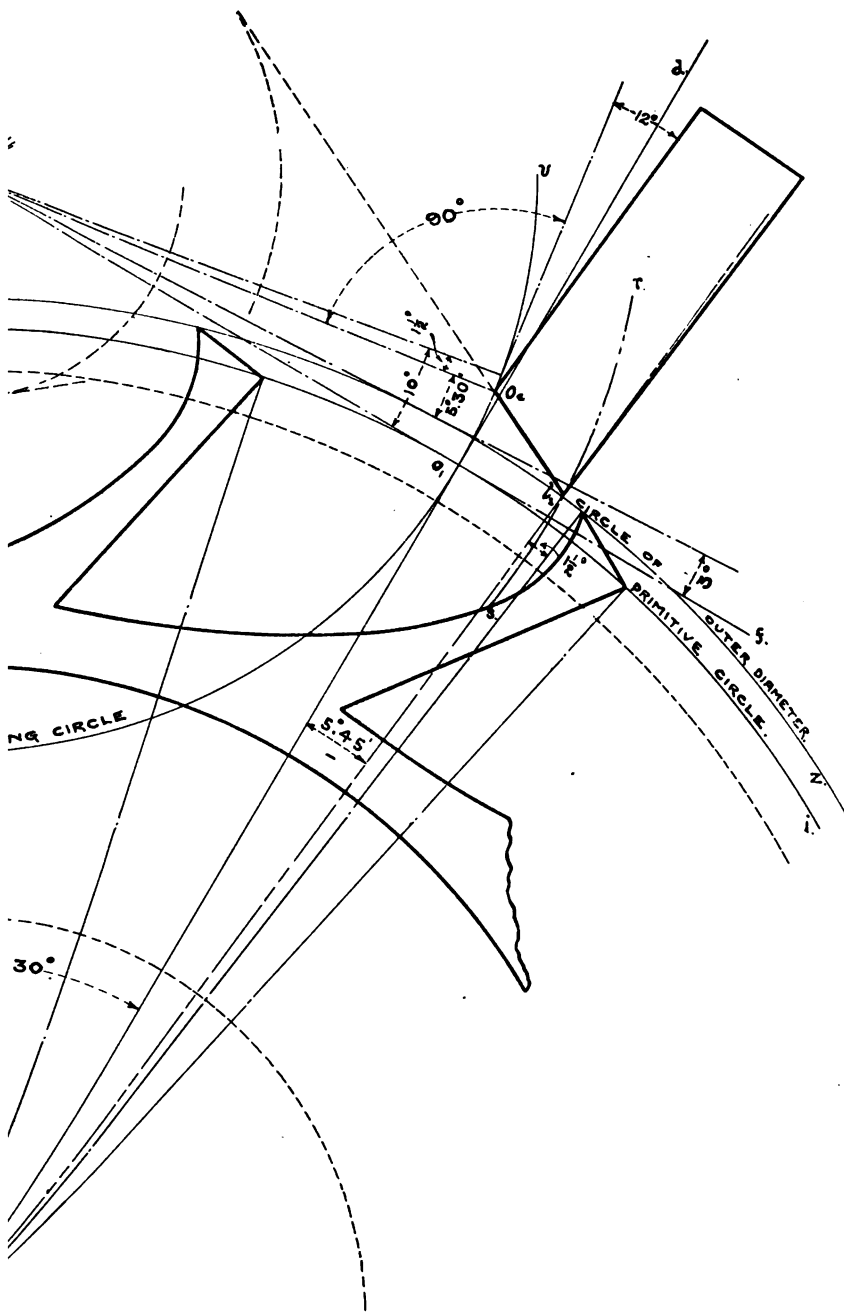



Other Valuable Reference Books

PUBLISHED BY

The Jewelers' Circular Publishing Co.,

11 John Street, New York.

WORKSHOP NOTES FOR JEWELERS AND WATCHMAKERS.

A collection of the latest practical receipts on the manufacture and repairing of watches and clocks, and on the various processes entering into the manufacture and repairing of jewelry, as coloring, polishing, enameling, annealing, oxydizing, etc.; in short, a thorough compendium of the numerous mechanical departments of the jeweler's and watchmaker's shop.

Third Edition. 305 pages, clear type, thoroughly systematized, bound in cloth.....Price, **\$2.50.**

TRADE MARKS OF THE JEWELRY AND KINDRED TRADES.

A complete collection of illustrations and representations of marks REGISTERED and UNREGISTERED, used by the manufacturers and dealers of jewelry, silver ware, American watches, foreign watches, watch cases, silver plated ware, souvenir silver ware, imitation precious stones, clocks, optical goods, tools, materials, pottery and porcelain, cut glass and cognate lines.

TO WHICH ARE ADDED

The Text of the National Trade-Mark Law, Treasury Department Regulations bearing upon trade-marks; a Review of the National Law and the Common Law on trade-marks; the exact Texts of the Silver and Gold Stamping Laws of the different States of the Union; together with Historical Articles by Authoritative Writers on old Makers' marks.

Over 2,250 marks. A most useful and valuable work.

THE SUBJECT OF UNIVERSAL ADMIRATION.

7 x 10½, bound in unusually heavy and durable cloth cover. Price (with Supplement).....**\$2.50**

MONOGRAMS FROM THE JEWELERS' CIRCULAR.

Consisting of 44 pages, 10 x 13 inches, each page containing 48 monograms, six different styles, all susceptible to combinations, producing a veritably illimitable number of monograms. Most useful book to jewelers doing engraving.

Bound in flexible cloth cover.....Price, **\$1.50**

VEST POCKET BUYERS' DIRECTORY of the Manufacturers, Jobbers and Importers in the Jewelry and Kindred Trades.

A securely bound little volume of all the manufacturers, importers, jobbers, etc., throughout the country; thoroughly classified and conveniently arranged for reference. An indispensable adjunct to the business of any jeweler.

Price, **50 cents.**

In Preparation.

ENCYCLOPEDIA - DICTIONARY AND REFERENCE HAND BOOK OF THE OPHTHALMIC SCIENCES.
Giving elaborate definitions and discourses on all the technical terms entering into Optometry and Ophthalmology, by Dr. R. H. KNOWLES.

THE JEWELERS' CIRCULAR-WEEKLY.

THE REPRESENTATIVE ORGAN OF THE JEWELRY AND KINDRED INDUSTRIES.
PUBLISHED WEEKLY.

Oldest Established Publication in the Trade. Established 1869. Largest Aggregate Circulation. Greatest Aggregate Volume.

Comprehensive Weekly Review of the Trade in all the Ramifications of its Different Branches.

All the News of the Trade. Fresh, Full, Accurate, Reliable.

Twenty valuable Departments bearing upon All Branches of the Jewelers' Business, all tending to advance the interests of the Jeweler and make his Business Profitable.

Always in advance of the times, fostering matters of moment to the trade at large, and to the retail Jeweler in particular.

A great Storehouse of Information for the Nominal Sum of \$2.00 a year.

THE JEWELERS' CIRCULAR PUBLISHING CO.,
11 John Street, New York.